

**L10 Lubricator – Standard**

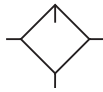

**Features**

- Stainless Steel Construction Handles Most Corrosive Environments
- 1/8" Female Threaded Drain
- Fillable Under Pressure
- Meets NACE Specifications MR-01-75/ISO 15156
- High Flow: 1/2" - 100 SCFM<sup>§</sup>

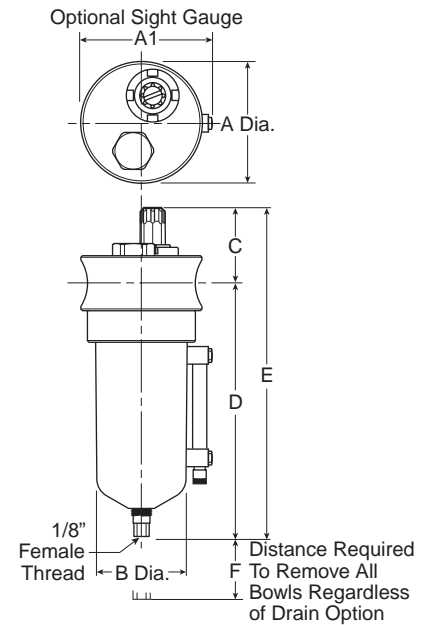

<b>Port Size</b>	<b>NPT</b>	<b>BSPB</b>
	<b>Manual Twist Drain</b>	<b>Manual Twist Drain</b>
1/2"	<b>Metal Bowl With Sight Gauge</b>	
	<b>L10-04WSS</b>	L10G04WSS

<b>L10 Lubricator Dimensions</b>		
<b>A</b> 2.38 (60)	<b>A1</b> 2.50 (64)	<b>B</b> 1.75 (44)
<b>C</b> 1.81 (46)	<b>D</b> 5.00 (127)	<b>E</b> 6.81 (173)
<b>F</b> 3.50 (89)		

**Bold Items are Most Popular.**  
**For other models refer to ordering information below.**

<sup>§</sup> SCFM = Standard cubic feet per minute at 90 PSIG inlet, and 5 PSIG pressure drop.

inches  
(mm)

**Ordering Information**

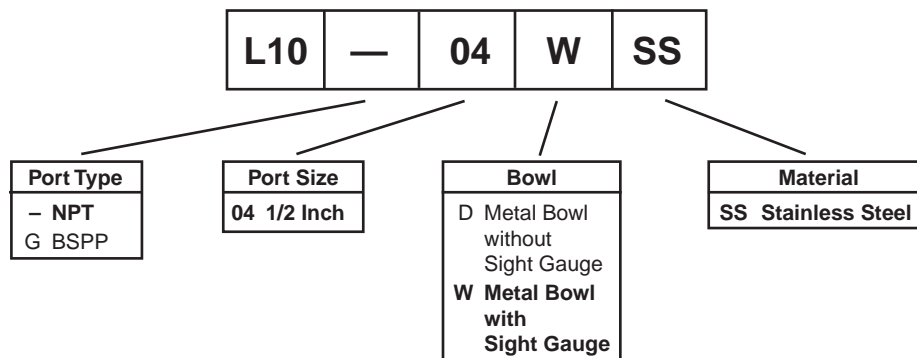

**BOLD ITEMS ARE MOST POPULAR.**

Operation

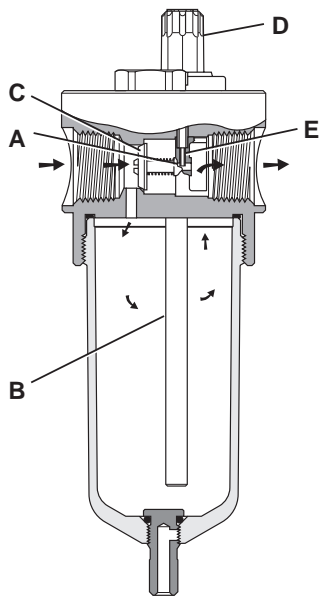

Air flowing through the unit goes through two paths. At low flow rates the majority of the air flows through the Venturi section (A). The rest of the air opens the check valve (C). The velocity of the air flowing through the Venturi section (A) creates a pressure drop. This lower pressure allows the oil to be forced from the reservoir through the pickup tube (B) and travels up to the metering screw (D). The rate of oil delivery is then controlled by adjusting the metering screw (D). Oil flows past the metering screw (D) and forms a drop in the nozzle tube (E). As the oil drops through the dome (F) and back into the Venturi section (A), it is broken up into fine particles. It is then mixed with the air flowing past the check valve (C) and is carried downstream. As the air flow increases the check valve (C) will open more fully. This additional flow will assure that the oil delivery rate will increase linearly with the increase of air flow.

Technical Information

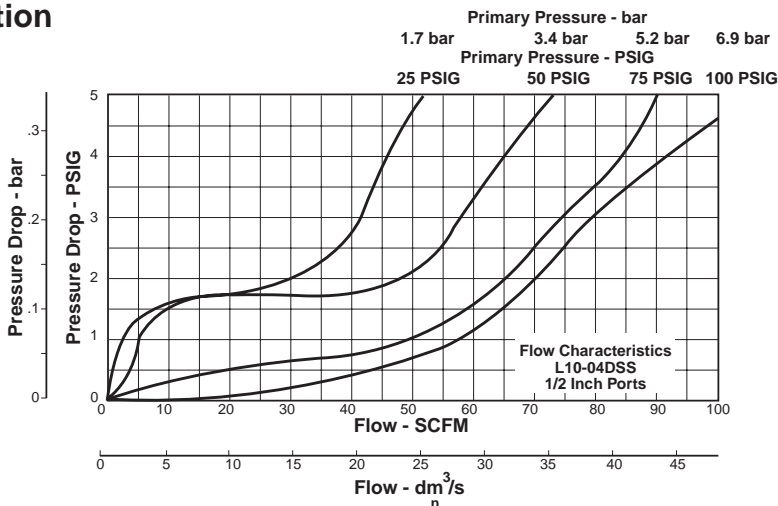

L10 Filter Kits & Accessories

Drain Kit –

- Manual Twist Drain –
- Small (Old) ..... SA600Y7-1SS
- Large (New) ..... SAP05481

Pipe Nipple –

- 1/2" 316 Stainless Steel ..... 616A28-SS

- Sight Dome Kit ..... RKL10SS

Specifications

- Bowl Capacity ..... 4.0 Ounces
- Port Threads ..... 1/2 Inch
- Pressure & Temperature Ratings –
- Metal Bowl (D) ..... 300 PSIG Max (20.7 bar)
- 0°F to 150°F (-18°C to 66°C)

- Metal Bowl (W) ..... 0 to 250 PSIG (0 to 17.2 bar)
- 0°F to 150°F (-18°C to 66°C)

Note: Air must be dry enough to avoid ice formation at temperatures below 32°F (0°C).

- Weight ..... 1.9 lb. (0.85 kg)

Materials of Construction

- Body ..... 316 Stainless Steel
- Bowl ..... 316 Stainless Steel
- Dip Tube ..... 316 Stainless Steel
- Drain ..... 316 Stainless Steel
- Fill Plug ..... 316 Stainless Steel
- Seals ..... Fluorocarbon
- Sight Dome ..... Nylon
- Sight Gauge ..... Isoplast

