

**B548, B558 Filter / Regulator – Miniature**

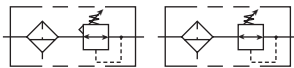

**Features**

- Stainless Steel Construction Handles Most Corrosive Environments
- Large Diaphragm to Valve Area Ratio for Precise Regulation and High Flow Capacity
- 1/8" Female Threaded Drain
- Meets NACE Specifications MR-01-75/ISO 15156.
- High Flow: 1/4" – 12 SCFM<sup>§</sup>



**B548**



**B558**

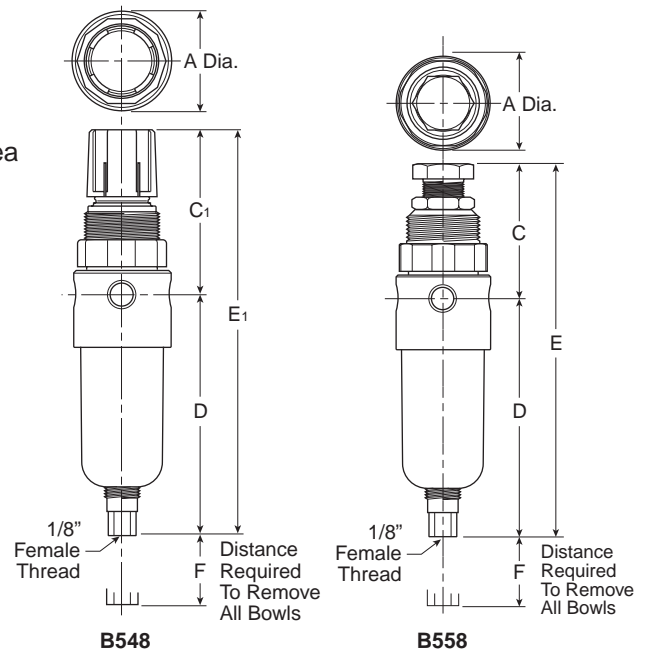

Series	Adjustment Type	Port Size	NPT	BSP
B548	Knob	1/4"	<b>B548-02DHCSS</b>	B548G02DHCSS
B558	All Metal	1/4"	<b>B558-02DHCSS</b>	B558G02DHCSS

B548, B558 Piggyback Dimensions		
<b>A</b> 1.56 (40)	<b>C</b> 2.17 (55)	<b>C<sub>1</sub></b> 2.63 (67)
<b>D</b> 3.63 (92)	<b>E</b> 5.80 (147)	<b>E<sub>1</sub></b> 6.26 (159)
<b>F</b> 1.58 (40)		

Standard part numbers shown bold. For other models refer to ordering information below.

<sup>§</sup> SCFM = Standard cubic feet per minute at 100 PSIG inlet, 75 PSIG no flow secondary setting and 15 PSIG pressure drop.

**⚠ WARNING**

**Product rupture can cause serious injury.  
 Do not connect regulator to bottled gas.  
 Do not exceed maximum primary pressure rating.**

inches (mm)  
 NOTE: 1.25 Dia. (32mm) hole required for panel mounting.

**Ordering Information**

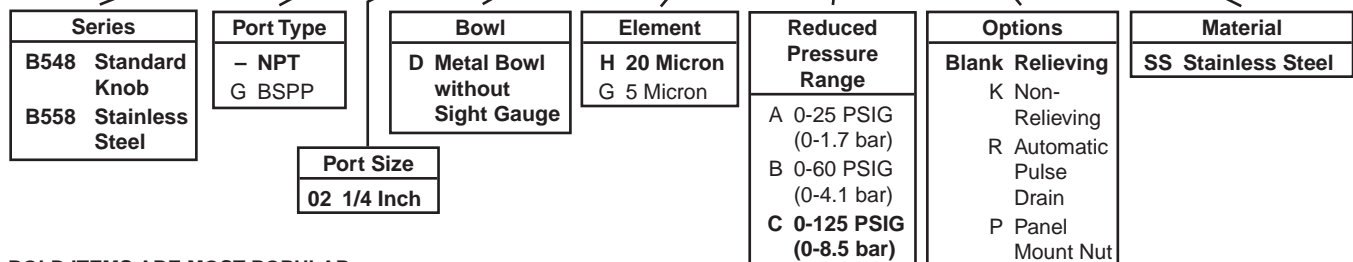

**BOLD ITEMS ARE MOST POPULAR.**

**Operation**

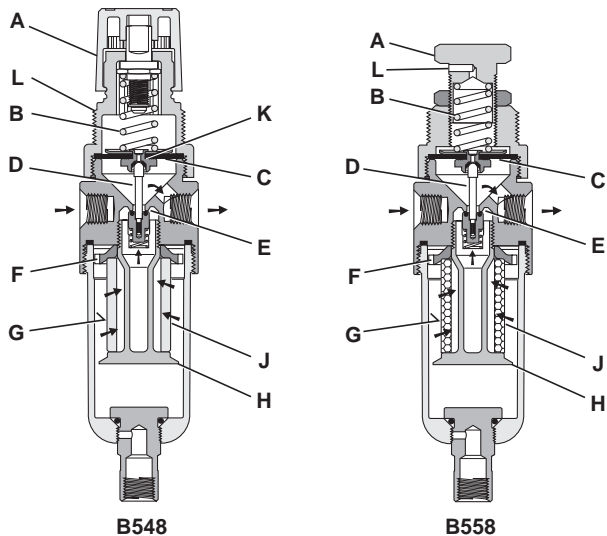

Turning the adjusting knob (A) clockwise applies a load to control spring (B) which forces diaphragm (C) and valve poppet assembly (D) to move downward allowing filtered air to flow through the seat area (E) created between the poppet and the seat. “**First stage filtration**”. Air pressure supplied to the inlet port is directed through deflector plate (F) causing a swirling centrifugal action forcing liquids and coarse particles to the inner bowl wall (G) and down below the lower baffle (H) to the quiet zone. After liquids and large particles are removed in the first stage of filtration “**second stage filtration**” occurs as air flows through element (J) where smaller particles are filtered out and retained. The air flow now passes through seat area (E) to the outlet port of the unit. Pressure in the downstream line is sensed below the diaphragm (C) and offsets the load of spring (B). When downstream pressure reaches the set-point, poppet valve assembly (D) and diaphragm (C) move upward closing seat area (E). Should downstream pressure exceed the desired regulated pressure, the excess pressure will cause the diaphragm (C) to move upward opening vent hole (K) venting the excess pressure to atmosphere through the hole in the bonnet (L). (This occurs in the standard relieving type filter/regulators only.)

**Technical Information**

**CAUTION:**

**REGULATOR PRESSURE ADJUSTMENT –**

The working range of knob adjustment is designed to permit outlet pressures within their full range. Pressure adjustment beyond this range is also possible because the knob is not a limiting device. This is a common characteristic of most industrial regulators, and limiting devices may be obtained only by special design.

For best performance, regulated pressure should always be set by increasing the pressure up to the desired setting.

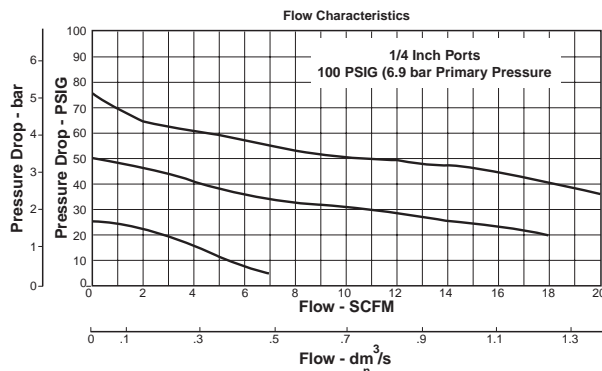

**B548, B558 Regulator Kits & Accessories**

- B558 Bonnet Kit (Knob Included) .....CKR354YSS
- B548 Bonnet Kit (Knob Included) .....CKR364YSS
- Drain Kit –**
- Automatic Pulse Drain ..... RK504SY-SS
- Manual Twist Drain –
- Small (Old) ..... SA600Y7-1SS
- Large (New) ..... SAP05481
- Filter Element Kits –**
- Particulate (5 Micron) ..... EK504VY
- Particulate (20 Micron) ..... EK504Y
- Gauge (Stainless) –**
- 160 PSIG (0 to 1100 kPa), 1-1/2" Face .....K4515N14160SS
- Panel Mount Bracket (Stainless)..... 161X57-SS**
- Panel Mount Nut –**
- Stainless ..... R05X51-SS
- Plastic.....R05X51-P
- Pipe Nipple –**
- 1/4" 316 Stainless Steel ..... 616Y28-SS
- Service Kit –**
- Relieving ..... RK549YSS
- Non-Relieving..... RK548YSS
- Springs –**
- 0-25 PSIG Range ..... SPR-375-2-SS
- 0-60 PSIG Range ..... SPR-376-1-SS
- 0-125 PSIG Range..... SPR-377-1-SS

- Filter Rating .....20 Micron
- Gauge Port .....1/4 Inch
- Operation ..... Fluorocarbon Diaphragm
- Port Threads .....1/4 Inch
- Pressure & Temperature Ratings –**
- B548 ..... 300 PSIG Max (20.7 bar)
- 0°F to 150°F (-18°C to 66°C)
- B558 ..... 300 PSIG Max (20.7 bar)
- 0°F to 180°F (-18°C to 82°C)
- Auto Pulse Drain..... 10 to 175 PSIG (0 to 12 bar)
- 32°F to 150°F (0°C to 66°C)

**Note: Air must be dry enough to avoid ice formation at temperatures below 32°F (0°C).**

- Sump Capacity ..... 0.4 Ounce
- Weight ..... 0.6 lb. (0.27 kg)

**Materials of Construction**

- Adjustment Mechanism / Springs .....316 Stainless Steel
- Body .....316 Stainless Steel
- Bonnet (B548) ..... Acetal
- Bonnet (B558) .....316 Stainless Steel
- Bottom Plug .....316 Stainless Steel
- Knob (B548) ..... Polypropylene
- Knob (B558) .....316 Stainless Steel
- Poppet .....316 Stainless Steel
- Seals ..... Fluorocarbon

**Specifications**

- Bowl Capacity ..... 1.0 Ounces

