



Modular Air Package



General Description

The Versa Modular Air Package is a compact air management system, that will provide a full range of pneumatic accessories and functions to meet the needs of most control systems in the actuator control industry. Major components are shutoff valves, check valves, filter/regulators, speed controls and directional control valves.

Design Benefits

Versa's VMAP simplifies the design process by combining all the components of a common circuit, into one integrated assembly. Whether a standard shutoff circuit or an intricate control system, VMAP has the features to meet the requirements of any control project. VMAP will reduce costs, components, engineering, vendors, weight, and save time.

TROUBLE FREE. Designed with integral assembly flanges combined with all O-ring interface sealing and standard fasteners. Long leak free service life is accomplished. No custom or flat gaskets to leak or brackets to fail.

EFFICIENCY. VMAP's modular design effectively groups common automation and controls components together in user approved groupings to combine features and reduce size and weight.

TECHNOLOGY. Utilizing the latest in computer aided design and finite element software. Flow is maximized yielding the highest flow in the smallest of packages.

PROVEN. VMAP is based on Versa's field proven V-316 Series product. Over 30 years of acceptance in providing bubble tight sealing through Versa's packed plunger technology.

CUSTOM CIRCUITRY is achieved through modular design by simply combining various components to create the desired circuit.

FLEXIBILITY. Many standard and custom circuits are easily created using the VMAP modular concept.

RELIABILITY. The reliability of the Versa V-316 Series combined with industry approved materials yields a proven product. SIL (Safety Integral Levels) exceeding most application requirements.

INNOVATIVE. Through the use of investment casting technology main components are integrated saving space while reducing potential leakage points.

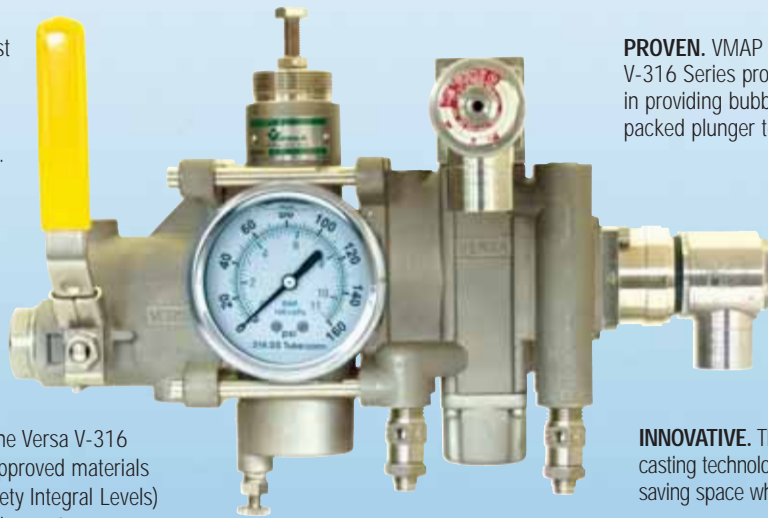

Engineering Benefits

- Standard or custom circuits available utilizing VMAP's modular components.
- No need for developing a bill of materials for fittings, tubing and bracketing.
- No need for designing a complete layout of many different system components.
- Convenience of one purchase order and one vendor.
- No need for designing brackets for many individual components.

Field Benefits

- Reparability ease; by removing a few screws and the various modules can be disassembled and inspected. No tubing or fittings to remove.
- Field configurability of function after installation; add more valves as the requirements of the process change.
- 10 year warranty.

Installation Benefits

- Reducing fittings, tubing and related labor costs.
- Reduction in size and weight.
- One component to mount.

Current Technology

NEW



VMAP and Panel shown at scale



VMAP will reduce engineering, costs,

Modular Air Package



Product Benefits

The primary product goal is that VMAP is designed for long trouble free service life. All components are 316 stainless steel. A proven corrosive free material in the harshest of environments. All components are assembled utilizing a Versa designed common assembly flange with 'O' ring sealing. The 'O' ring sealing is superior to flat gaskets or threaded ports. The integral flanges offer an extremely durable, flexible and modular system allowing for a leak free installation, easy field maintenance and the ability for field convertibility.

Integral Speed Controls

Many Standard VMAP Modular Components for standard and custom circuitry

Auxiliary ports for monitoring and pressure take off

Integral Check Valve

Shutoff Ball Valve with locking handle

Gauge, glycerin filled

Filter Regulator with integral drain

Pilot Shutoff Module mounting pad for custom circuitry

Integral mounting means

Two sizes

Standard Versa solenoid and latching options available

Solenoids for world-wide use



UL, CSA, and ATEX, approved Hazardous location-XX solenoid shown



ATEX approved (d) Flameproof -XDAS solenoid shown

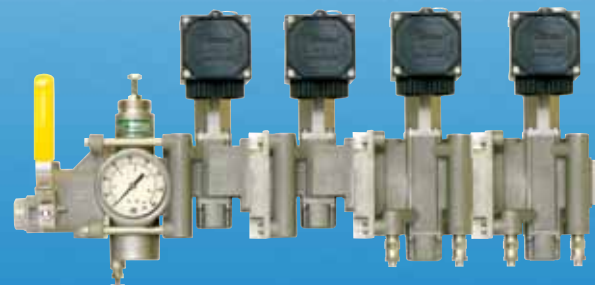

ATEX approved (m) Encapsulation -XMAA solenoid shown

components, vendors, weight and time!

Modular Air Package

Typical Actuator Control Circuits

Single Acting Actuator

Complete with regulator, filter, gauge,
3-Way solenoid valve and speed controls.

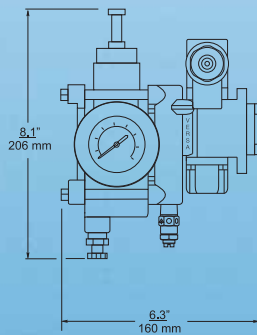
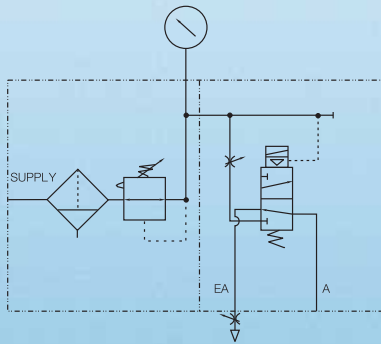

Bill of Materials

Part Number	Description
MSO2-3-3-316-VA	Shutoff Module, Supply access only
ARF-3112-316-GAG-VAB	Air Prep Module, Regulator, Filter, Gauge
VSG-3321-316-BC3-SC-VA-XX-D024	Control Valve Module, 3-Way Solenoid with Speed Controls

Double Acting Actuator Electrical Shut Down Function

Complete with manual shutoff, regulator, filter, gauge, 4-Way solenoid valve, speed controls and pilot solenoid shutoff valve.

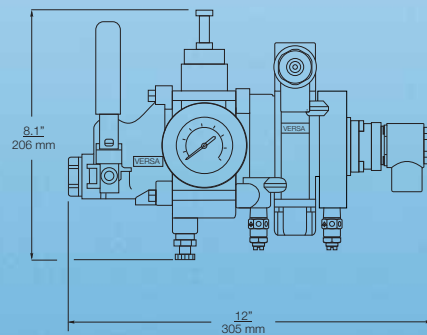
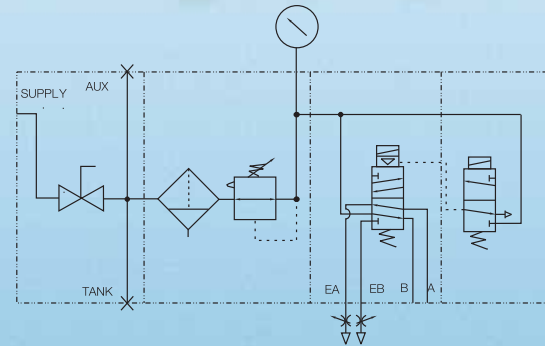

Bill of Materials

Part Number	Description
MSO2-3-316-VA	Shutoff Module, Shutoff manual valve
ARF-3112-316-GAG-VA	Air Prep Module, Regulator, Filter, Gauge
VSG-4322-316-BC3-VAA-XX-D024	Control Valve Module, 4-Way Solenoid with Speed Controls
E5SM-3011-34-316-VA-XX-D024	Pilot Solenoid Module, 3-Way Solenoid

Modular Air Package

Typical Actuator Control Circuits



Double Acting Actuator with Manual Latching

Complete with manual shutoff, check valve, regulator, filter, gauge, 4-Way solenoid valve, speed controls, and shutoff valve with latching reset.

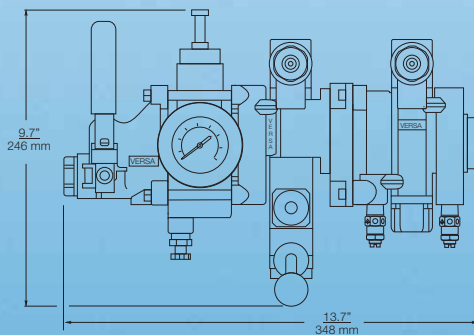
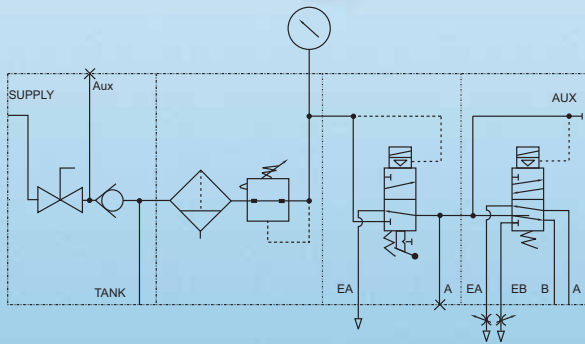

Bill of Materials

Part Number	Description
MS02-3-316-VA-CK	Shutoff Module, Shutoff manual valve with Check Valve and Auxiliary port
ARF-3112-316-GAG-VA	Air Prep Module, Regulator, Filter, Gauge
VAG-3321-316-181D-VAS-XX-D024	Control Valve Module, 3-Way Solenoid, Manual Latching Reset with control valve shutoff adapter kit
VSG-4322-316-BC3-VA-XX-D024	Control Valve Module, 4-Way Solenoid with Speed Controls

Dual Single Acting Actuators (or one single acting actuator with redundancy)

Complete with manual shutoff, check valve, regulator, filter, gauge, two 3-Way solenoid valves, and relief valve.

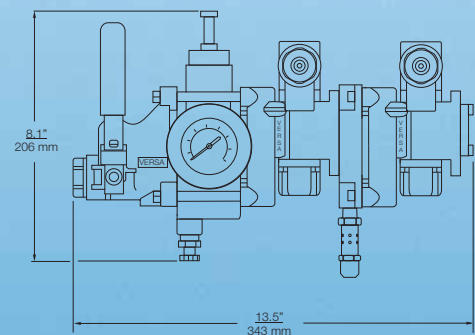
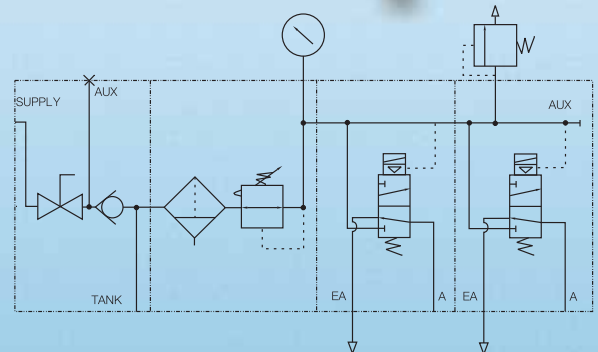

Bill of Materials

Part Number	Description
MS02-3-316-VA-CK	Shutoff Module, Shutoff manual valve with Check Valve
ARF-3112-316-GAG-VA	Air Prep Module, Regulator, Filter, Gauge
VSG-3321-316-VAP-XX-D024	Control Valve Module, 3-Way Solenoid with multi station adapter kit
VSG-3321-316-VA-XX-D024	Control Valve Module, 3-Way Solenoid
RV-3-316-120	Pressure Relief Valve 120 psi set

Shutoff Module

Shutoff Module

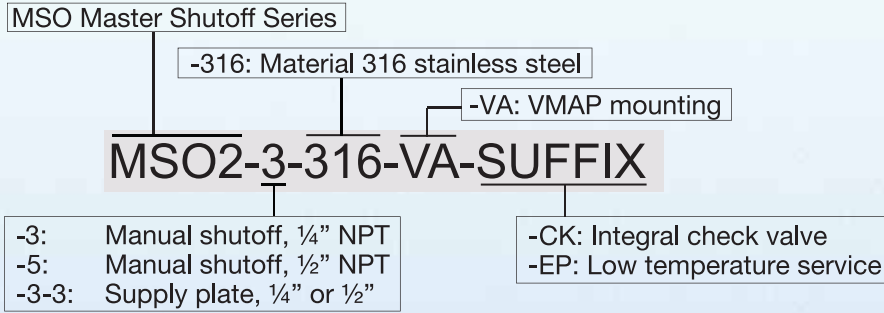

Shutoff Module Specifications

Description:	Shutoff valve	Shutoff valve with check	Supply plate
Size:	1/4" or 1/2"	1/4" or 1/2"	1/4" or 1/2"
Valve Function:	2-Way, manual	2-Way, manual with check valve	n/a
Pressure*:	0 to 290 psi	0 to 290 psi	n/a
Port Size,			
Inlet,	1/4": 1/4" NPT 1/2": 1/2" NPT	1/4" NPT 1/2" NPT	n/a n/a
Tank,	1/4": 1/2" NPT** 1/2": 1/2" NPT**	1/2" NPT 1/2" NPT	n/a n/a
Aux	1/4": 1/4" NPT** 1/2": 1/4" NPT**	1/4" NPT** 1/4" NPT**	n/a n/a
Temperature:	-20°F to 180°F (-29°C to 82°C) -55°F to 180°F (-48°C to 82°C) with low temperature option (-EP)		
Material, Body:	316 Stainless Steel		
Seals:	Viton Ethylene Propylene seal on low temperature (-EP)		

*Pressure rating for Inlet station only. Ultimate system pressure based on down stream components. For higher pressures consult factory.
** Supplied with plug.

Air Prep Module

Air Prep Module

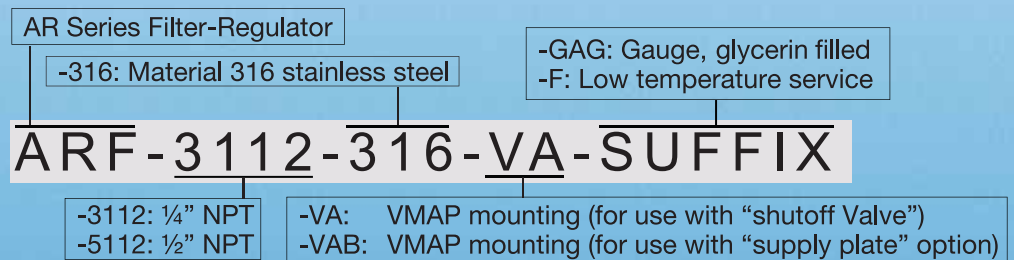

Air Preparation Module Specification

Description:	Filter-Regulator Set*
Size:	1/4" or 1/2"
Regulator type:	Relieving
Pressure**:	290 psi, inlet 10 to 100 psi outlet
Temperature:	-20°F to 180°F (-29°C to 82°C) -55°F to 180° F (-48°C to 82°C) with low temperature option (-F)
Material, Body:	316 Stainless Steel
Seals:	Viton
Filter:	25 micron supplied with manual drain
Gauge:	Optional. Stainless steel, glycerin filled



**AR Series literature

* Kits available for non-Versa supplied regulator sets
**Pressure rating for Air Preparation station only. Ultimate system pressure based on down stream components.
For other outlet pressures and more air prep options please see AR Series literature.

Control Valve Module



Control Valve Module



VA type shown



*Series V-316 Bulletin

V-316 Series

Actuator Type* SG:
Single Solenoid spring return*

-316: Material 316 stainless steel

-XX: Hazardous Location, NEMA 7 & 9
-XN: (d) Flameproof, ATEX
-XNW: (d) Flameproof, with Junction box, ATEX
-XMA: (m) Encapsulated, (e) Increased Safety, ATEX
-XIF: (ia) Intrinsic Safe, ATEX

VSG-3321-316-VA-XX-SUFFIX-Voltage

Body Type* 3321: 3-Way, 2 Position, InPilot, Normally Closed, 1/4" size

-VA: VMAP mounting
-VAX3: VMAP mounting with Auxiliary Port, 1/4" NPT
-VAA: VMAP mounting with Pilot Solenoid Shutoff interface
-VAP: Multi station adapter Kit
-VAS: Control Valve Shutoff adapter Kit



Bleed Controls: Exhaust
-BC3: 1/4" NPT Thread
-BC5: 1/2" NPT Thread



Dust Excluder: Exhaust
-DE3: 1/4" NPT Thread
-DE5: 1/2" NPT Thread



-SC: Integral inlet Speed Control



-VB: Brackets, optional mounting



Pressure relief valve
RV-3-316-120 (120 psi set)

-EP: Low temperature option

Control Valves Module Specifications

Description: Solenoid control valve
Function: 3 or 4-Way
Port Size: 1/4" or 1/2" NPT (cylinder & Exhaust)
Pressure*: 40 to 175 psi (range for Solenoid Spring return valve with hazardous location rating*)
Flow:** 1/4" 1.9 Cv
1/2" 4.8 Cv
Temperature: -20°F to 180°F (-29°C to 82°C)
-55°F to 180°F (-48°C to 82°C) with low temperature option (-EP)
Material, Body: 316 Stainless Steel
Seals: Viton
Ethylene Propylene seal on low temperature (-EP)

*Pressure rating dependent on solenoid option selection. For options and pressures please see V-316 Series literature.
**Flow ratings for valve station only. Ultimate system flow based on complete system components.

Pilot Solenoid Shutoff Module

Pilot Solenoid Shutoff Module



VAA type valve with VA type E5SM Shown

E5 Series

-316: Material 316 stainless steel

-VA: VMAP mounting

E5SM-3011-34-316-VA-XX-Voltage

Body: 3-Way, normally closed, direct acting

See Control Valve Module above

Pilot Solenoid Shutoff Module Specifications

Description: Solenoid valve
For use as pilot shutoff valve
Function: 3-Way Normally Closed
Pressure: 150 psi
Temperature: -20°F to 180° F (-29°C to 82°C)
-55°F to 180° F (-48°C to 82°C) with low temperature option (-EP)
Material, Body: 316 Stainless Steel
Seals: Viton
Ethylene Propylene seal on low temperature (-EP)

*Pressure rating dependent on solenoid option selection. For options and pressures please see E Series literature.
**Flow ratings for valve station only. Ultimate system flow based on complete system components.



Versa has been supplying the oil and gas industry with pneumatic and hydraulic components for over 50 years. We have built a reputation for quality that is unsurpassed in the market for high performance solenoids, pneumatic relays and resets, and pilot valves.

WARNINGS REGARDING THE DESIGN APPLICATION, INSTALLATION AND SERVICE OF VERSA PRODUCTS

The warnings below must be read and reviewed before designing a system utilizing, installing, servicing, or removing a Versa product. Improper use, installation or servicing of a Versa product could create a hazard to personnel and property.

DESIGN APPLICATION WARNINGS

Versa products are intended for use where compressed air or industrial hydraulic fluids are present. For use with media other than specified or for non-industrial applications or other applications not within published specifications, consult Versa.

Versa products are not inherently dangerous. They are only a component of a larger system. The system in which a Versa product is used must include adequate safeguards to prevent injury or damage in the event of system or product failure, whether this failure be of switches, regulators, cylinders, valves or any other system component. System designers must provide adequate warnings for each system in which a Versa product is utilized. These warnings, including those set forth herein, should be provided by the designer to those who will come in contact with the system.

Where questions exist regarding the applicability of a Versa product to a given use, inquiries should be addressed directly to the manufacturer. Confirmation should be obtained directly from the manufacturer regarding any questioned application prior to proceeding.

INSTALLATION, OPERATION AND SERVICE WARNINGS

Do not install or service any Versa product on a system or machine without first depressurizing the system and turning off any air, fluid, or electricity to the system or machine. All applicable electrical, mechanical, and safety codes, as well as applicable governmental regulations and laws must be complied with when installing or servicing a Versa product.

Versa products should only be installed or serviced by qualified, knowledgeable personnel who understand how these specific products are to be installed and operated. The individual must be familiar with the particular specifications, including specifications for temperature, pressure, lubrication, environment and filtration for the Versa product which is being installed or serviced. Specifications may be obtained upon request directly from Versa. If damages should occur to a Versa product, do not Operate the system containing the Versa product. Consult Versa for technical information.

LIMITED WARRANTY DISCLAIMER AND LIMITATION OF REMEDIES

Versa's Series products are warranted to be free from defective material and workmanship for a period of ten years from the date of manufacture, provided said products are used in accordance with Versa specifications. Versa's liability pursuant to that warranty is limited to the replacement of the Versa product proved to be defective provided the allegedly defective product is returned to Versa or its authorized distributor. Versa provides no other warranties, expressed or implied, except as stated above. There are no implied warranties of merchantability or fitness for a particular purpose. Versa's liability for breach of warranty as herein stated is the only and exclusive remedy and in no event shall Versa be responsible or liable for incidental or consequential damages.

Versa Products Company Inc.

22 Spring Valley Road
Paramus, New Jersey 07652
USA
Phone: 201-843-2400
Fax: 201-843-2931

Versa BV

Prins Willem Alexanderlaan 1429
7321 GB Apeldoorn
The Netherlands
Phone: 01131-55-368-1900
Fax: 01131-55-368-1909



www.versa-valves.com
email: sales@versa-valves.com