

ID Series In-line Desiccant Dryers

Extremely dry air and gas for critical point of use applications.

In-line desiccant dryers deliver extremely dry compressed air or natural gas in critical point of use applications. With no moving parts and no power requirements, an in-line desiccant dryer can be installed virtually anywhere. Each dryer consists of a charge of either color indicating silica gel or molecular sieve, providing a -40°F pressure dew point. Models ID15-SW and ID15-IND use a disposable desiccant cartridge, making service quick and simple with no tools necessary. Model ID35 holds a greater volume of loose color indicating silica gel, extending the service interval for higher flow applications.

ID series dryers are ideal for:

- Instrument gas dehydration
- Single point of use
- Low and intermittent flows
- Low flow process protection

FEATURES

15 to 35 SCFM @ 100 PSIG

-40°F pressure dew point

No power or moving parts

Compressed air or natural gas service



BENEFITS OF THE ID SERIES

Simple // Dependable // Versatile

vanairsystems.com

SPECIFICATIONS

ID15-SW & ID15-IND

- Housing: Cast aluminum alloy
- Differential pressure at 100 PSI: less than 1PSI
- Depressurization valve: 1/4" NPT Ball Valve
- Sight window (ID15-SW)
- Color change indicating stick (ID15-IND)
- 23 oz. color indicating silica gel (ID15-SW; SG-23 cartridge model)
- 16 oz. molecular sieve (ID15-IND; MS-16 cartridge model)
- ID15-IND for compressed air service only

ID35

- Housing: Steel, ASME Sec. VIII, Div. I
- Differential pressure at 100 PSI: less than 1
- Desiccant drain port: 1/2" NPT
- Sight window
- 8 lbs. color indicating silica gel

DIMENSIONS & SPECIFICATIONS

Model No.	A		B		C		Inlet Conn.	Outlet Conn.	Maximum Working Pressure PSIG / BARG	Weight	
	in	cm	in	cm	in	cm				lbs	kg
ID15-IND	18 3/4	48	3 1/2	9	5 1/2	14	1/2" NPT	1/2" NPT	200 / 13.8	5	2.3
ID15-SW	14 1/2	37	3 1/2	9	5 1/2	14	1/2" NPT	1/2" NPT	200 / 13.8	6	2.3

MAXIMUM CAPACITIES SCFM/Nm3hr for -40°F PDP

Model No.	25 PSIG 1.7 BARG		50 PSIG 3.4 BARG		100 PSIG 6.9 BARG		150 PSIG 10.3 BARG		200 PSIG 13.8 BARG		250 PSIG 17.2 BARG	
ID15 IND/SW	5	8	8.5	14	15	24	21	34	28	45	—	
ID35	14	23	20	32	35	56	50	80	66	106	81	130

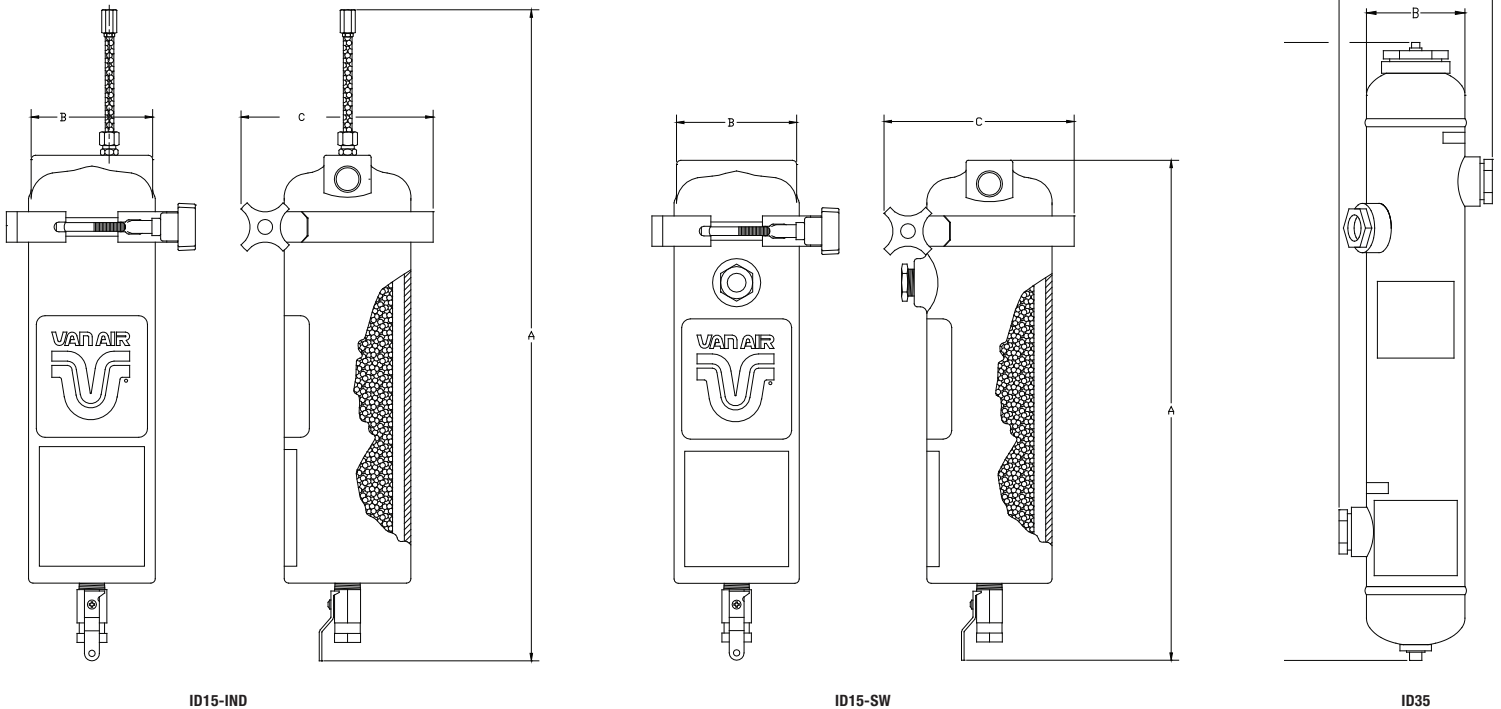

2950 Mechanic Street, Lake City, PA 16423, USA | Toll Free Phone 800-840-9906 | Corporate Fax 814-774-0778 | Order Entry Fax 814-774-3482

Distributed By:



ID Series - PDF Downloads

Installation, Operation and Maintenance Manuals

ID15-IND



ID15-SW



ID35



MS-16 Cartridge



SG-23 Cartridge



Sales Drawings

ID15-IND

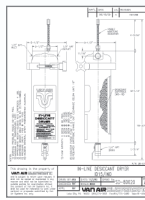

ID15-SW

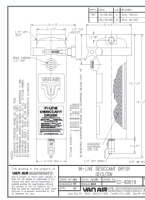

ID35

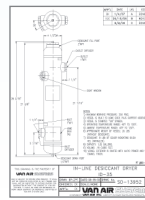

Cartridge and Desiccant Life

ID15 IND

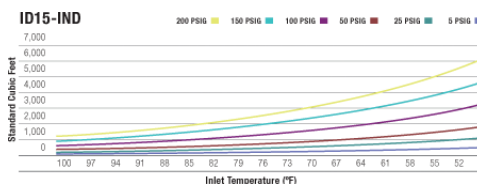

ID15 SW

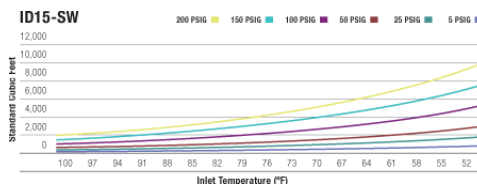

ID35

