

AIRPRO[®] 250

PNEUMATIC CYLINDER



- Adjustable Cushions
- Proximity Switch Capability
- Non-Rotating Rods Available
- Externally Removable Rod Bushing
- 15 Standard Mounting Styles

NON-ROTATING ROD

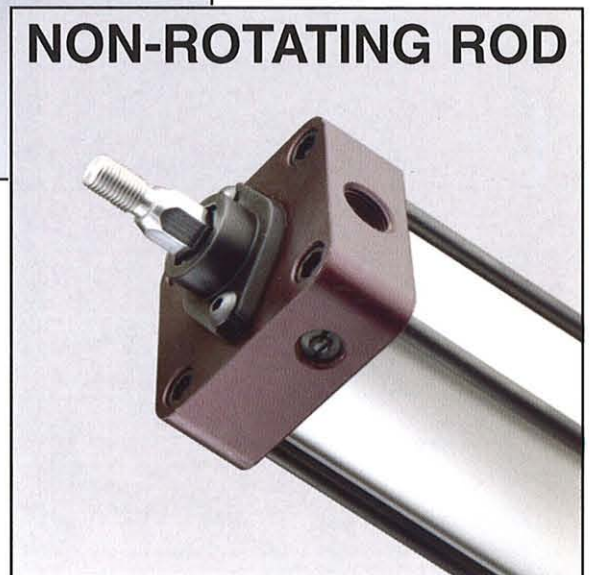

NFPA INTERCHANGEABLE



National
**FLUID
POWER**
Association
MEMBER

250A^{series}-1 PNEUMATIC CYLINDER

Designed to meet the needs of machine builders today, tomorrow, and beyond. Over fifty years of cylinder manufacturing experience has been built into this durable design.

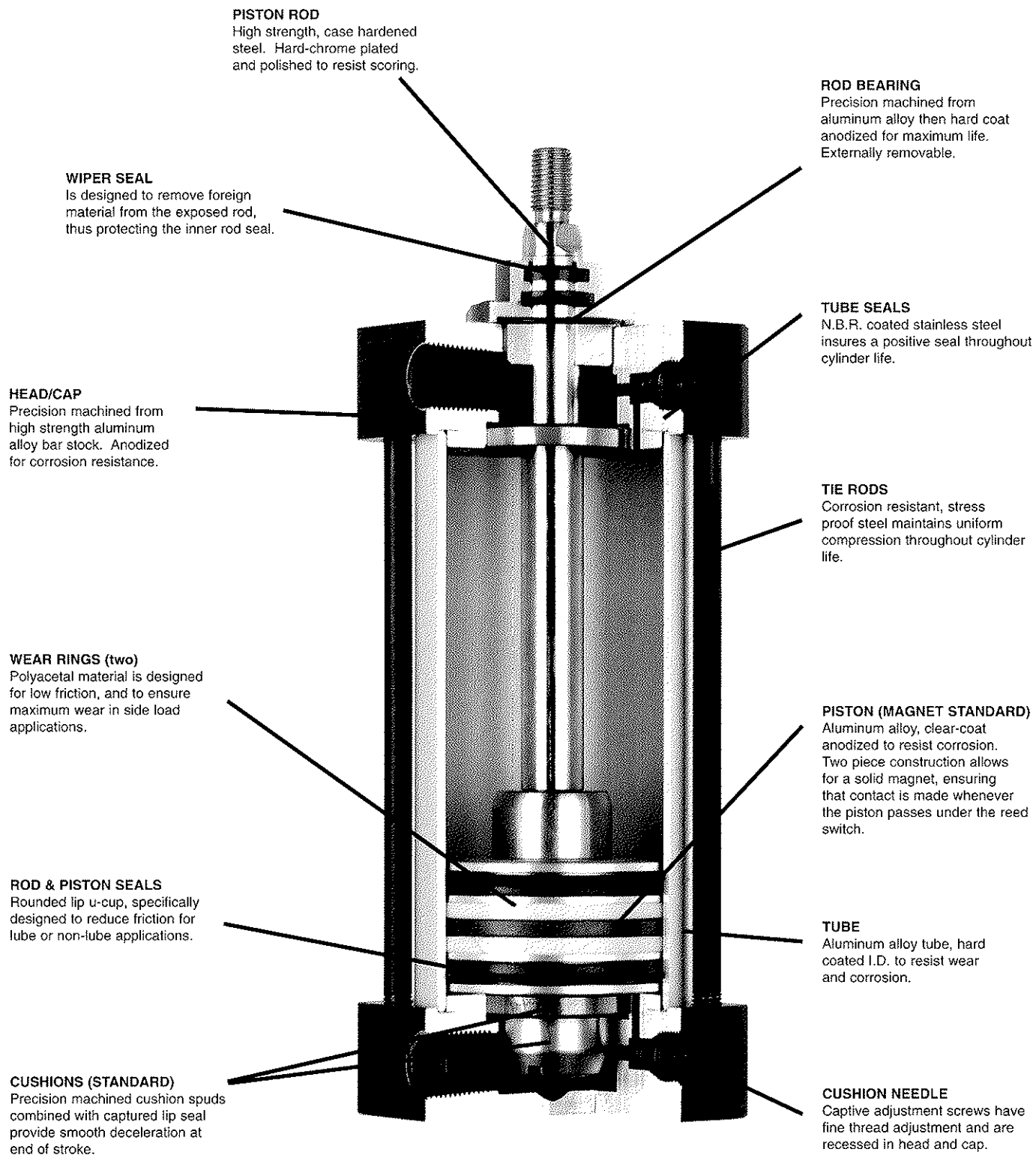

C O N T E N T S

FEATURES	PAGE 2
CYLINDER SPECIFICATIONS / SWITCH SPECIFICATIONS	PAGE 3
HOW TO ORDER	PAGE 4
RELATED SPECIFICATIONS	PAGE 4
SECTIONAL DRAWINGS	PAGE 5
DIMENSIONAL DRAWINGS	PAGE 6-17
ACCESSORIES	PAGE 18
SWITCH SET OPERATION AND HANDLING	PAGE 19-21

FEATURES

BORE SIZES 1½" UP TO 6"

Available bores 1½", 2", 2½", 3¼", 4", 5", 6" with various types of mountings and rod end accessories.

HIGH STRENGTH PISTON ROD

Piston rods are hard chrome plated to resist scoring and corrosion and assure maximum seal life.

NON-ROTATING RODS AVAILABLE

Hexagonal rods eliminate the need for whirl-stop guides. We have an entire series of non-rotating rod cylinders, which enable construction of more functional systems.

MAGNET INTEGRATED IN PISTON

Pistons come equipped with a magnet. Mounting a magnetic proximity switch will convert a basic cylinder into a position indicator without internal modification.

ADJUSTABLE CUSHIONS

Cylinders come standard with adjustable cushions in both the head and cap.

250A-1

CYLINDER SPECIFICATIONS

Rod style	Round rod		Non-Rotating Rod	
	Basic	Switch set	Basic	Switch set
Type				
Cylinder bore	1½" • 2" • 2½" • 3¼" • 4" • 5" • 6"			
Working fluid	Air			
Lubrication	Not necessary (Pre-lubricated for extended life)			
Operating pressure range	15 — 250 psig (0.1~1.75 MPa)			
Speed range (※1)	2~25inch/sec		2~20inch/sec	
Temperature range	14~158°F (-10~+70°C) at non-freezing condition			
Structure of cushioning	Both ends cushioned (Standard)			
Tolerance of rotation angle	—		2", 2½": ±1°, 3¼", 4", 5": ±.5°	
Max. allowable torque (lb·in)	—		2", 2½": 8.7lb·in, 3¼", 4", 5": 85lb·in	
Tolerance of stroke	Bore 1½"~2": 20" max. $\pm .08$ / $\pm .11$ 20" min. $\pm .12$ / $\pm .00$ Bore 2½"~3¼"~4"~5": 20" max. $\pm .10$ / $\pm .00$ 20" min. $\pm .15$ / $\pm .00$			
Mounting type	SD • TS(MS4) • FA(MF1) • LA(MS2) • LB(MS1) • LE(MS7) • CB(MP1) • CD(MP2) • CC(MP4) • TC(MT4) FB(MF2) • TA(MT1) • TB(MT2) • BX(MX1) • CX(MX2) • HX(MX3) ()NFPA Mounting Code			
Accessories	Rod end attachments: Ttype(Rod end eye) Ytype(Rod end clevis)			

※1 When setting the switch at an intermediate position, keep cylinder's maximum speed must be under 10inch/sec. for detection.

MAGNETIC PROXIMITY SWITCH SPECIFICATIONS

Code	With DIN connector	SR100	SR200	SR300	SR400
	With lead wire (5ft.)	SR101	SR201	SR301	SR401
	With lead wire (16ft.)	SR105	SR205	SR305	SR405
Voltage range	DC5~50V			AC80~220V	
Current range	60°C max.	6~30mA	25~50mA	0~20mA	2~300mA
	70°C	6~25mA	25~40mA		
Max contact capacity	1.5W			2VA	30VA
Leakage current	0			1mA max.	
Actuating time	1msec max.			1msec max.	
Return time	1msec max.			1msec max.	11msec max.
Allowable shock	30G			30G	
Indicator lamp	LED (Lights with switch ON)			Neon tube (Lights with switch OFF)	
Applicable load	Ultra-miniature relay Sequencer	Miniature relay	Ultra-miniature relay Miniature relay	Ultra-miniature relay General use relay Sequencer Miniature solenoid Pilot lamp	

INNER CIRCUIT OF REED SWITCH

- SR100 • SR101 • SR105
- SR200 • SR201 • SR205 (DC)

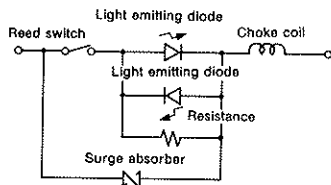

Lamp turns on when switching

- SR300 • SR301 • SR305 (AC)

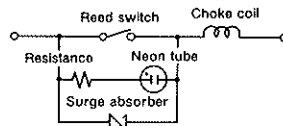

Lamp turns on when un-switching

- SR400 • SR401 • SR405 (AC)

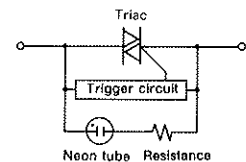

Lamp turns on when un-switching

BRACKET FOR MAGNETIC PROXIMITY SWITCH

Bore	Parts No.
150(1½")	BK-25
200(2") • 250(2½")	BK-31
325(3¼") • 400(4")	BK-38
500(5") • 600(6")	BK-50

250A-1

HOW TO ORDER

250A-1

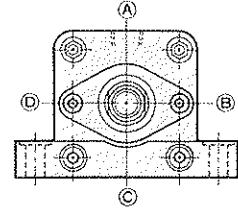
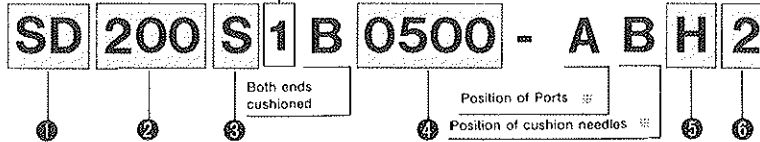

①	Mounting type SD • TS(MS4) • LB(MS1) • LA(MS2) • LE(MS7) • FA(MF1) • FB(MF2) • CB(MP1) • CD(MP2) • CC(MP4) • TC(MT4) TA(MT1) • TB(MT2) • BX(MX1) • CX(MX2) • HX(MX3) () NFPA Style
②	Bore size 150—1½" • 200—2" • 250—2½" • 325—3¾" • 400—4" • 500—5" • 600—6"
③	Rod type type-S : indicates standard rod type. type-M : indicates oversize rod type. (150-1½" Bore size only available for cap side cushion without switch capability) type-G : indicates non - rotating rod type.
④	Cylinder stroke (Hundredths of inch) *Stroke length must be indicated as 4 digits. First and second digit = stroke / inch ; third and fourth digit = stroke / hundredths of an inch. (Example 0325 : 3¼" stroke)
⑤	Switch code A : SR300A B : SR301A E : SR101 F : SR201 G : SR301 H : SR401 J : SR100 K : SR200 L : SR300 M : SR400 Blank : Without switch P : SR105 Q : SR205 R : SR305 S : SR405 (Refer to page 3)
⑥	Number of switches

※ Standard position of Port is (A) while that of cushion valve is (B)
※ The position symbol of port and cushion valve are clockwise from rod side view

ROD END STYLES

STYLE 1 (NFPA : style SM)

STYLE 2 (NFPA style IM)

STYLE 3 (NFPA style SF)

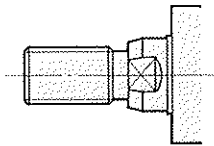

STANDARD

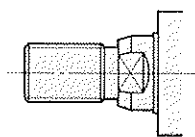

OPTIONAL

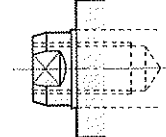

OPTIONAL

ACCESSORIES

- Rod end eye type T
- Rod end clevis type Y

Bore \ Rod dia	Part No.													
	150(1½")		200(2")		250(2½")		325(3¾")		400(4")		500(5")		600(6")	
Rod end	S	M	S-G	M	S-G	M	S-G	M	S-G	M	S-G	M	S	
TYPE T	T-1	T-2	T-1	T-2	T-1	T-2	T-2	T-3	T-2	T-3	T-2	T-3	T-3	
TYPE Y	Y-1	Y-2	Y-1	Y-2	Y-1	Y-2	Y-2	Y-3	Y-2	Y-3	Y-2	Y-3	Y-3	

MAXIMUM ALLOWABLE STROKE

Unit : inch

Bore	Round Rod	Non-rotating rod
1½	40	20
2	50	30
2½	60	30
3¾	70	40
4	75	40
5	75	40
6	75	N/A

*Longer strokes available. Consult Factory.

MINIMUM STROKE OF CYLINDER WITH SWITCH

Unit : inch

Bore	Minimum Stroke
1½	1
2	1
2½	1
3¾	1
4	1
5	1
6	1

WEIGHT TABLES

Unit : Lbs

Bore (inch)	Basic weight			Mounting accessory weight							Switch weight (1pcs.)	Additional weight per 1 inch of stroke		
	S rod	M rod	G rod	LB (MS1)	LA (MS2)	LE (MS7)	FA(MF1) FB(MF-2)	CB (MP1)	CD (MP2)	CC (MP4)		S rod	M rod	G rod
1½	1.52	-	-	0.49	0.90	0.44	0.51	0.60	0.71	0.84	0.26	0.19	-	-
2	2.36	2.78	2.34	0.62	1.17	0.71	0.77	0.86	0.97	1.10		0.23	0.23	0.22
2½	3.28	3.70	3.26	0.73	1.41	1.17	1.04	1.06	1.17	1.48		0.25	0.38	0.24
3¾	6.94	7.72	6.88	1.10	3.35	1.74	2.29	2.03	2.36	3.88		0.48	0.67	0.45
4	9.19	9.96	9.08	1.26	4.14	2.47	3.62	2.73	3.09	4.50		0.50	0.70	0.48
5	15.17	15.94	15.08	2.29	7.89	4.23	6.06	4.28	4.85	5.29		0.64	0.84	0.62
6	23.5	-	-	5.5	12.0	6.5	10.0	10.0	12.5	10.5	0.9	-	-	

Calculation formula:

$$\text{Cylinder weight} = \text{Basic weight} + (\text{switch weight}) + \text{Mounting accessory weight} + (\text{additional weight per 1 inch of stroke} \times \text{Cylinder stroke inch})$$

Calculation example:

$$\text{Round rod fundamental cylinder 3 switches with wire, LB mounting Bore 2½ inches, stroke 5 inches } 2.89 + (0.26 \times 3) + 0.73 + (0.24 \times 5) = 5.64 \text{ Lbs.}$$

250A-1

CONSTRUCTION / PARTS LIST

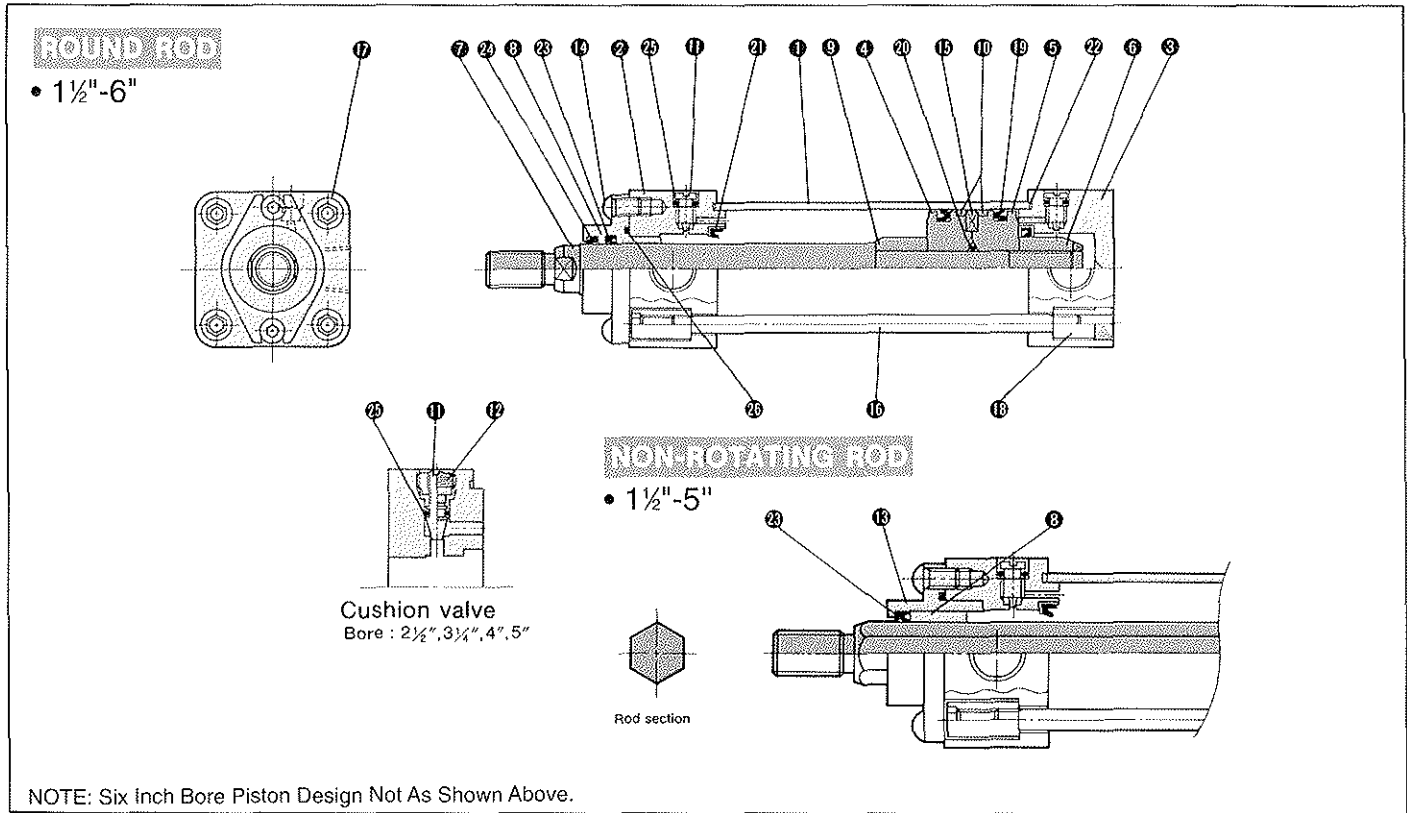

PARTS LIST

No.	Name	Material	Q'ty
①	Cylinder body	Aluminum alloy	1
②	Head cover	Aluminum alloy	1
③	End cap	Aluminum alloy	1
④	Piston	Aluminum alloy	1
⑤	Piston	Aluminum alloy	1
⑥	Piston nut	Carbon steel	1
⑦	Piston rod	Carbon steel	1
⑧	Rod bushing	Aluminum alloy	1
⑨	Cushion ring	Carbon steel	1

No.	Name	Material	Q'ty
⑩	Wear ring	Polyacetal resin	2
⑪	Cushion needles	Chromium-Molybdenum steel	2
⑫	Cushion plug	Chromium-Molybdenum steel	2
⑬	Seal housing	Aluminum alloy	1
⑭	Rod bushing bolt	Chromium-Molybdenum steel	2
⑮	Magnet	-----	1
⑯	Tie rod	Carbon steel	4
⑰	Tie rod nut A	Chromium-Molybdenum steel	4
⑱	Tie rod nut B	Carbon steel	4

SEALS LIST

Bore (inch)	Name Rod style Material	⑩ Piston seal		⑪ Piston rod Oring		⑫ Cushion seal		⑬ End Seal		⑭ Rod seal			⑮ Wiper seal		⑯ Cushion needle Oring	⑰ Rod bushing Oring
		Nitrile rubber	S-G	M	Canned nitrile rubber	Canned nitrile rubber	S	M	G	S	M	Nitrile rubber	Nitrile rubber	Nitrile rubber	Nitrile rubber	
			Nitrile rubber	Nitrile rubber												Polyurethane rubber
1 1/2	XU-1%	AN6227-9	—	CS-20	TW-1.5	XU-%	—	—	XD-%	—	AN6227-3	MS28775-021				
2	XU-1%	AN6227-9	AN6227-14	CS-30	TW-2	XU-%	XU-1	PGR-14A	XD-%	XD-1	AN6227-3	MS28775-027				
2 1/2	XU-2%	AN6227-9	AN6227-14	CS-30	TW-2.5	XU-%	XU-1	PGR-14A	XD-%	XD-1	AN6227-3	MS28775-027				
3 1/2	XU-2%	AN6227-14	AN6227-19	CS-40	TW-3.25	XU-1	XU-1%	PGR-23	XD-1	XD-1%	AN6227-3	MS28775-032				
4	XU-3%	AN6227-14	AN6227-19	CS-40	TW-4	XU-1	XU-1%	PGR-23	XD-1	XD1%	AN6227-3	MS28775-032				
5	XU-4%	AN6227-14	AN6227-19	CS-40	TW-5	XU-1	XU-1%	PGR-23	XD-1	XD-1%	AN6227-3	MS28775-032				
6	DXP-150	AN6227-19	—	CS-40	"O-Ring" TO-6	XU-1%	—	—	XD-1%	—	AN6227-3	MS28775-032				

DIMENSIONS / SD TYPE (BASIC)

Unit : inch

ROUND ROD NON-ROTATING

• Non-rotating rod

Hexagonal rod width across flats

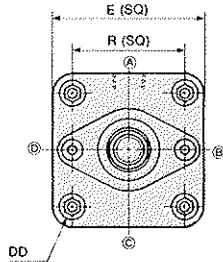
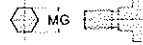

• Rod end STYLE 1 NFPA style SM

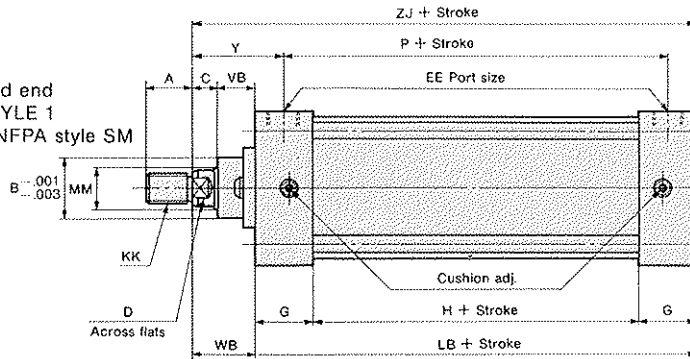

SWITCH SET CYLINDER

ROD END STYLE (OPTIONAL)

STYLE 2 NFPA style IM

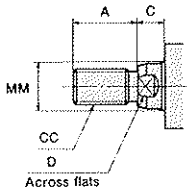

STYLE 3 NFPA style SF

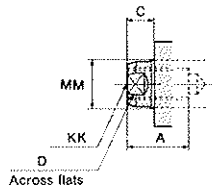

DIMENSIONS			
Bore	RV	RY	UX
1½	3.2	1.6	.16
2	3.8	1.9	.16
2½	4.2	2.1	.22
3½	4.8	2.4	.16
4	5.4	2.7	.16
5	6.2	3.1	.28
6	7.2	3.6	.28

DIMENSIONAL TABLE

Unit : inch

BORE SIZE	ROD DIA MM	A	B	C	D	DD	E	EE (NPTF)	G	H	ROD END STYLE 1	ROD END STYLE 2	ROD END STYLE 3	LB	MG	P	R	VB	WB	Y	ZJ
											KK	CC	KK								
1½	S ¾	¾	1.125	¾	½	¾-28	2	¾-18	1.102	1.421	¼-20	¼-20	¼-20	3%	—	2.52	1.43	¾	1	1.55	4%
2	S ¾	¾	1.125	¾	½	¾-24	2½	¾-18	1.102	1.421	¼-20	¼-20	¼-20	3%	.551	2.52	1.84	¾	1	1.55	4%
	M 1	1½	1.500	¾	¾	¾-24	2½	¾-18	1.102	1.421	¼-16	¾-14	¼-16	3%	—	2.52	1.84	¾	1½	1.93	5
2½	S ¾	¾	1.125	¾	½	¾-24	3	¾-18	1.102	1.546	¼-20	¼-20	¼-20	3%	.551	2.65	2.19	¾	1	1.55	4%
	M 1	1½	1.500	¾	¾	¾-24	3	¾-18	1.102	1.546	¼-16	¾-14	¼-16	3%	—	2.65	2.19	¾	1½	1.93	5%
3½	S 1	1½	1.500	¾	¾	¾-24	3½	¾-14	1.417	1.416	¼-16	¾-14	¼-16	4½	.906	2.92	2.76	¾	1½	2.04	5%
	M 1½	1½	2.000	¾	1	¾-24	3½	¾-14	1.417	1.416	1-14	1½-12	1-14	4½	—	2.92	2.76	1	1½	2.29	5%
4	S 1	1½	1.500	¾	¾	¾-24	4½	¾-14	1.417	1.416	¼-16	¾-14	¼-16	4½	.906	2.92	3.32	¾	1½	2.04	5%
	M 1½	1½	2.000	¾	1	¾-24	4½	¾-14	1.417	1.416	1-14	1½-12	1-14	4½	—	2.92	3.32	1	1½	2.29	5%
5	S 1	1½	1.500	¾	¾	¾-20	5½	¾-14	1.417	1.666	¼-16	¾-14	¼-16	4½	.906	3.17	4.10	¾	1½	2.04	5%
	M 1½	1½	2.000	¾	1	¾-20	5½	¾-14	1.417	1.666	1-14	1½-12	1-14	4½	—	3.17	4.10	1	1½	2.29	6%
6	S 1½	1½	2.000	¾	1	¾-20	6½	¾-14	1.500	2.000	1-14	1½-12	1-14	5	—	3.50	4.88	1	1½	2.375	6%

250A-1

DIMENSIONS / DOUBLE ROD CYLINDER 250A-IW

Unit : inch

ROUND ROD

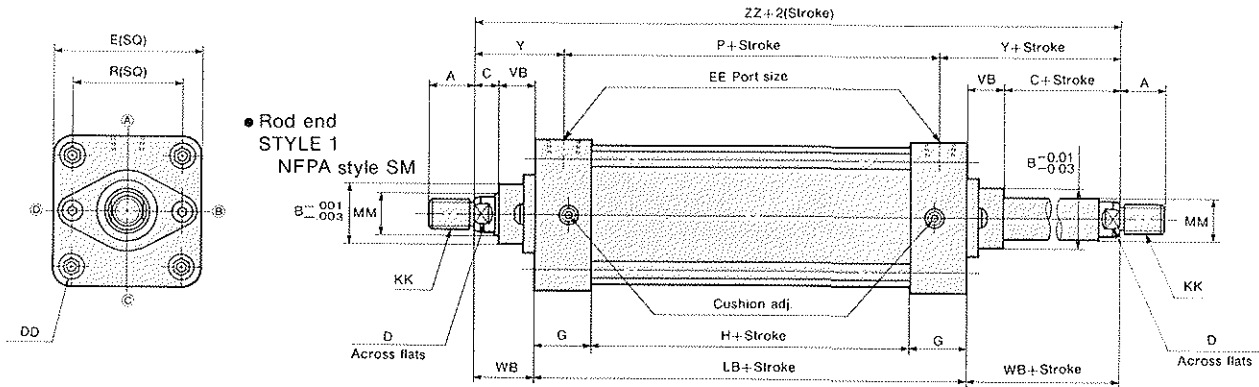

ROD END STYLE (OPTIONAL)

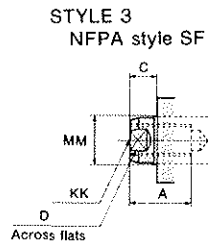
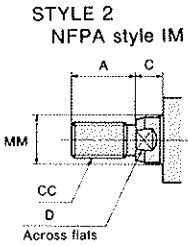

- Double Rod cylinders available in mounting styles SD, TS, LB, LA, LE, FA, FB, and TC.

DIMENSIONAL TABLE

Unit : inch

BORE SIZE	ROD DIA MM	A	B	C	D	DD	E	EE (NPTF)	G	H	ROD END STYLE 1	ROD END STYLE 2	ROD END STYLE 3	LB	P	R	VB	WB	Y	ZZ
											KK	CC	KK							
1½	S ¾	¾	1.125	¾	¾	¾-28	2	¾-18	1.102	1.421	¾-20	¾-20	¾-20	3%	2.52	1.43	¾	1	1.55	5%
	M 1	1	1.500	¾	¾	¾-24	2½	¾-18	1.102	1.421	¾-16	¾-14	¾-16	3%	2.52	1.84	¾	1½	1.93	6%
2	S ¾	¾	1.125	¾	¾	¾-24	3	¾-18	1.102	1.546	¾-20	¾-20	¾-20	3%	2.65	2.19	¾	1	1.55	5%
	M 1	1	1.500	¾	¾	¾-24	3	¾-18	1.102	1.546	¾-16	¾-14	¾-16	3%	2.65	2.19	¾	1½	1.93	6%
2½	S 1	1	1.500	¾	¾	¾-24	3½	¾-14	1.417	1.416	¾-16	¾-14	¾-16	4%	2.92	2.76	¾	1½	2.04	7
	M 1½	1	2.000	¾	1½	¾-24	3½	¾-14	1.417	1.416	1-14	1½-12	1-14	4%	2.92	2.76	1	1½	2.29	7½
4	S 1	1	1.500	¾	¾	¾-24	4½	¾-14	1.417	1.416	¾-16	¾-14	¾-16	4%	2.92	3.32	¾	1½	2.04	7
	M 1½	1	2.000	¾	1	¾-24	4½	¾-14	1.417	1.416	1-14	1½-12	1-14	4%	2.92	3.32	1	1½	2.29	7½
5	S 1	1	1.500	¾	¾	¾-20	5½	¾-14	1.417	1.666	¾-16	¾-14	¾-16	4%	3.17	4.10	¾	1½	2.04	7½
	M 1½	1	2.000	¾	1	¾-20	5½	¾-14	1.417	1.666	1-14	1½-12	1-14	4%	3.17	4.10	1	1½	2.29	7½
6	S 1	1	2.000	¾	1	¾-20	6½	¾-14	1.500	2.000	1-14	1½-12	1-14	5.00	3.50	4.88	1	1½	2.375	8½

DIMENSIONS / TS TYPE (SIDE TAPPED MOUNTING) / NFPA-MS4

Unit : inch

ROUND ROD NON-ROTATING

• Non-rotating rod

Hexagonal rod width across flats

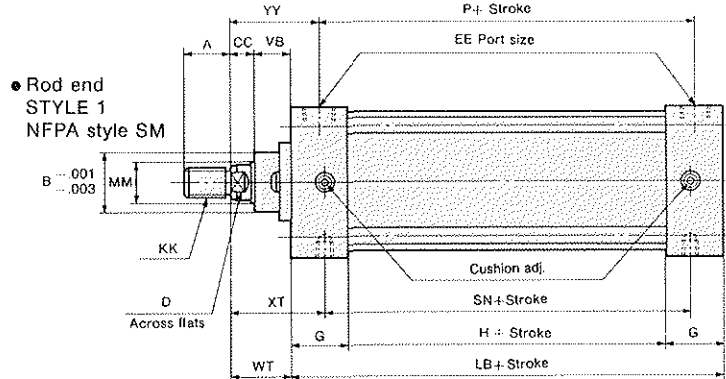
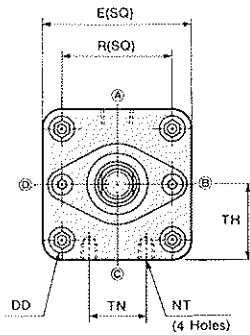
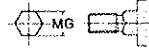

ROD END STYLE (OPTIONAL)

STYLE 2
NFPA style IM

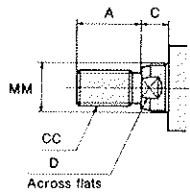

STYLE 3
NFPA style SF

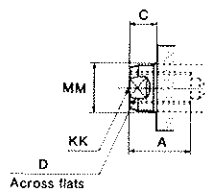

DIMENSIONAL TABLE

Unit : inch

BORE SIZE	ROD DIA MM	A	B	CC	D	DD	E	EE (NPTF)	G	H	ROD END STYLE 1	ROD END STYLE 2	ROD END STYLE 3	LB	MG	NT	P	R	SN	TH	TN	VB	WT	XT	YY
											KK	CC	KK												
1½	S ¾	¾	1.125	⅝	¾	⅝-28	2	⅝-18	1.102	1.421	⅝-20	⅝-20	⅝-20	3½	—	⅝-20	2.52	1.43	2½	1	¾	¾	1½	1½	1.80
2	S 1	1	1.125	⅝	¾	⅝-24	2½	⅝-18	1.102	1.421	⅝-20	⅝-20	⅝-20	3½	.551	⅝-18	2.52	1.84	2½	1½	¾	¾	1½	1½	1.80
	M 1 1/8	1 1/8	1.500	11/16	¾	⅝-24	2½	⅝-18	1.102	1.421	⅝-16	⅝-14	⅝-16	3½	—	⅝-18	2.52	1.84	2½	1½	¾	¾	1½	2½	2.18
2½	S 1 1/8	1 1/8	1.125	⅝	¾	⅝-24	3	⅝-18	1.102	1.546	⅝-20	⅝-20	⅝-20	3½	.551	⅝-16	2.65	2.19	2½	1½	1½	¾	1½	1½	1.80
	M 1 1/8	1 1/8	1.500	11/16	¾	⅝-24	3	⅝-18	1.102	1.546	⅝-16	⅝-14	⅝-16	3½	—	⅝-16	2.65	2.19	2½	1½	1½	¾	1½	2½	2.18
3½	S 1 1/2	1 1/2	1.500	¾	¾	⅝-24	3½	⅝-14	1.417	1.416	⅝-16	⅝-14	⅝-16	4½	.906	⅝-13	2.92	2.76	2½	1½	1½	¾	1½	2½	2.29
	M 1 3/8	1 3/8	2.000	¾	1	⅝-24	3½	⅝-14	1.417	1.416	1-14	1½-12	1-14	4½	—	⅝-13	2.92	2.76	2½	1½	1½	1	1½	2½	2.54
4	S 1 3/8	1 3/8	1.500	¾	¾	⅝-24	4½	⅝-14	1.417	1.416	⅝-16	⅝-14	⅝-16	4½	.906	⅝-13	2.92	3.32	2½	2½	2½	¾	1½	2½	2.29
	M 1 3/8	1 3/8	2.000	¾	1	⅝-24	4½	⅝-14	1.417	1.416	1-14	1½-12	1-14	4½	—	⅝-13	2.92	3.32	2½	2½	2½	1	1½	2½	2.54
5	S 1 3/4	1 3/4	1.500	¾	¾	⅝-20	5½	⅝-14	1.417	1.666	⅝-16	⅝-14	⅝-16	4½	.906	⅝-11	3.17	4.10	2½	2½	2½	¾	1½	2½	2.29
	M 1 3/4	1 3/4	2.000	¾	1	⅝-20	5½	⅝-14	1.417	1.666	1-14	1½-12	1-14	4½	—	⅝-11	3.17	4.10	2½	2½	2½	1	1½	2½	2.54
6	S 1 3/4	1 3/4	2.000	¾	1	⅝-20	6½	⅝-14	1.500	2.000	1-14	1½-12	1-14	5	—	⅝-10	3.50	4.88	3½	3½	3½	1	1½	2½	2.63

250A-1

DIMENSIONS / LB TYPE (SIDE END ANGLES MOUNTING) / NFPA-MS1

Unit : inch

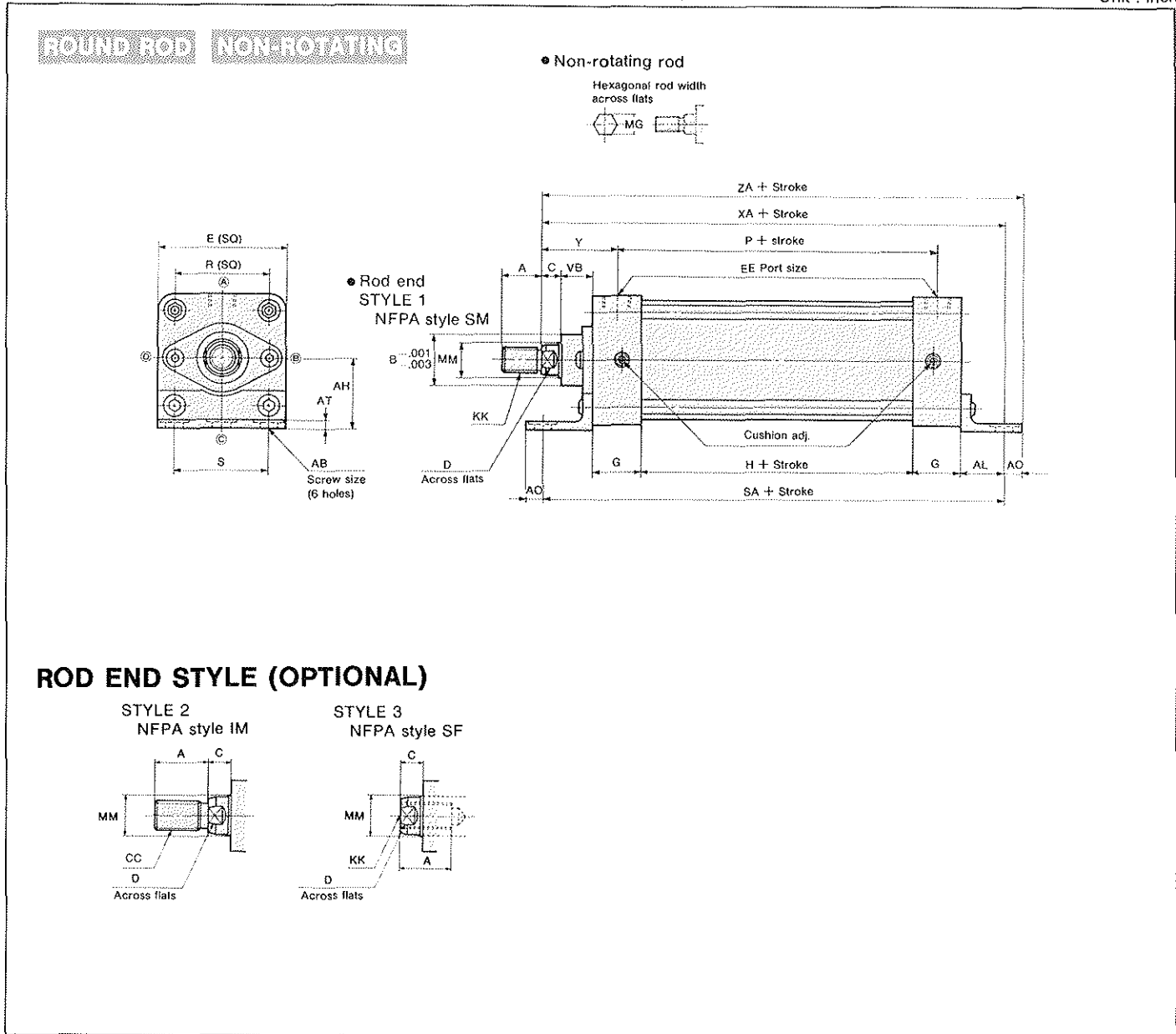

DIMENSIONAL TABLE

Unit : inch

BORE SIZE	ROD DIA MM	A	AB	AH	AL	AO	AT	B	C	D	E	EE (NPTF)	G	H	ROD END STYLE 1	ROD END STYLE 2	ROD END STYLE 3	MG	P	R	S	SA	VB	XA	Y	ZA
															KK	CC	KK									
1½	S	¾	¾	1½	1	¾	¾	1.125	¾	¾	2	¾-18	1.102	1.421	¾-20	¾-20	¾-20	—	2.52	1.43	1½	6	¾	5½	1.55	6
	M	1	1	1½	1	¾	¾	1.125	¾	¾	2½	¾-18	1.102	1.421	¾-20	¾-20	¾-20	.551	2.52	1.84	1½	6	¾	5½	1.55	6
2	S	1	1	1½	1	¾	¾	1.500	¾	¾	2½	¾-18	1.102	1.421	¾-16	¾-14	¾-16	—	2.52	1.84	1½	6	¾	6	1.93	6½
	M	1	1	1½	1	¾	¾	1.500	¾	¾	3	¾-18	1.102	1.546	¾-20	¾-20	¾-20	.551	2.65	2.19	2¼	6½	¾	5½	1.55	6½
2½	S	1	1	1½	1	¾	¾	1.125	¾	¾	3	¾-18	1.102	1.546	¾-20	¾-20	¾-20	.551	2.65	2.19	2¼	6½	¾	5½	1.55	6½
	M	1	1	1½	1	¾	¾	1.500	¾	¾	3	¾-18	1.102	1.546	¾-16	¾-14	¾-16	—	2.65	2.19	2¼	6½	¾	6	1.93	6½
3	S	1	1	1½	1	¾	¾	1.500	¾	¾	3	¾-14	1.417	1.416	¾-16	¾-14	¾-16	.906	2.92	2.76	2¼	7	¾	6	2.04	7
	M	1	1	1½	1	¾	¾	2.000	¾	1	3	¾-14	1.417	1.416	1-14	1½-12	1-14	—	2.92	2.76	2¼	7	1	7	2.29	7
4	S	1	1	1½	1	¾	¾	1.500	¾	¾	4	¾-14	1.417	1.416	¾-16	¾-14	¾-16	.906	2.92	3.32	3	7	¾	6	2.04	7
	M	1	1	1½	1	¾	¾	2.000	¾	1	4	¾-14	1.417	1.416	1-14	1½-12	1-14	—	2.92	3.32	3	7	1	7	2.29	7
5	S	1	1	1½	1	¾	¾	1.500	¾	¾	5	¾-14	1.417	1.666	¾-16	¾-14	¾-16	.906	3.17	4.10	4	7	¾	7	2.04	7
	M	1	1	1½	1	¾	¾	2.000	¾	1	5	¾-14	1.417	1.666	1-14	1½-12	1-14	—	3.17	4.10	4	7	1	7	2.29	8
6	S	1	1	1½	1	¾	¾	2.000	¾	1	6	¾-14	1.500	2.000	1-14	1½-12	1-14	—	3.50	4.88	5	8	1	8	2.375	8

DIMENSIONS / LA TYPE (SIDE LUGS MOUNTING) / NFPA-MS2

Unit : inch

ROUND ROD NON-ROTATING

• Non-rotating rod

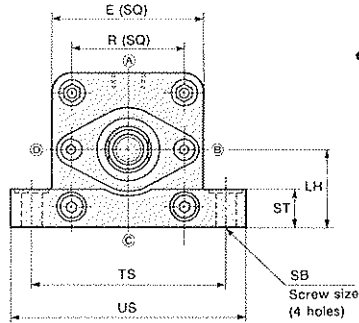
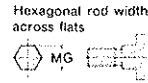

• Rod end STYLE 1
NFPA style SM

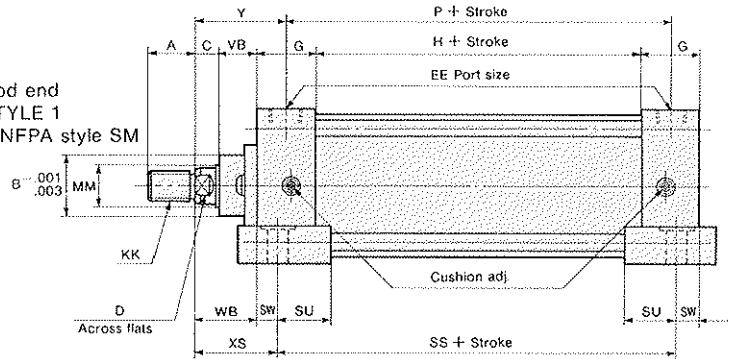

ROD END STYLE (OPTIONAL)

STYLE 2
NFPA style IM

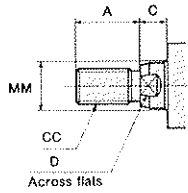

STYLE 3
NFPA style SF

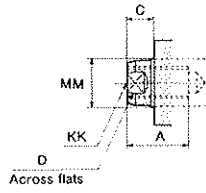

DIMENSIONAL TABLE

Unit : inch

BORE SIZE	ROD DIA MM	A	B	C	D	E	EE (NPTF)	G	H	ROD END STYLE 1	ROD END STYLE 2	ROD END STYLE 3	LH	MG	P	R	SB	SS	ST	SU	SW	TS	US	VB	WB	XS	Y
										KK	CC	KK															
1½	S ¾	¾	1.125	¾	¾	2	¾-18	1.102	1.421	¾-20	¾-20	¾-20	1	—	2.52	1.43	¾	2¾	½	¼	¾	2¾	3¾	¾	1	1¾	1.55
2	S ¾	¾	1.125	¾	¾	2½	¾-18	1.102	1.421	¾-20	¾-20	¾-20	1½	.551	2.52	1.84	¾	2¾	½	¼	¾	3¾	4	¾	1	1¾	1.55
	M 1 1¼	1.500	¾	¾	2½	¾-18	1.102	1.421	¾-16	¾-14	¾-16	1½	—	2.52	1.84	¾	2¾	½	¼	¾	¾	3¾	4	¾	1	1¾	1.93
2½	S ¾	¾	1.125	¾	¾	3	¾-18	1.102	1.546	¾-20	¾-20	¾-20	1½	.551	2.65	2.19	¾	3	½	¼	¾	3¾	4¾	¾	1	1¾	1.55
	M 1 1¼	1.500	¾	¾	3	¾-18	1.102	1.546	¾-16	¾-14	¾-16	1½	—	2.65	2.19	¾	3	½	¼	¾	¾	3¾	4¾	¾	1	1¾	1.93
3¾	S 1 1¼	1.500	¾	¾	3¾	¾-14	1.417	1.416	¾-16	¾-14	¾-16	1¾	.906	2.91	2.76	¾	3¾	¾	1	¾	¾	4¾	5¾	¾	1	1¾	2.04
	M 1 1¼	2.000	¾	¾	3¾	¾-14	1.417	1.416	1-14	1¾-12	1-14	1¾	—	2.91	2.76	¾	3¾	¾	1	¾	¾	4¾	5¾	1	1	2¾	2.29
4	S 1 1¼	1.500	¾	¾	4¾	¾-14	1.417	1.416	¾-16	¾-14	¾-16	2¾	.906	2.91	3.32	¾	3¾	¾	1	¾	¾	5¾	6¾	¾	1	1¾	2.04
	M 1 1¼	2.000	¾	¾	4¾	¾-14	1.417	1.416	1-14	1¾-12	1-14	2¾	—	2.91	3.32	¾	3¾	¾	1	¾	¾	5¾	6¾	1	1	2¾	2.29
5	S 1 1¼	1.500	¾	¾	5¾	¾-14	1.417	1.666	¾-16	¾-14	¾-16	2¾	.906	3.16	4.10	¾	3¾	1	1¾	¼	¾	6¾	8¾	¾	1	2¾	2.04
	M 1 1¼	2.000	¾	¾	5¾	¾-14	1.417	1.666	1-14	1¾-12	1-14	2¾	—	3.16	4.10	¾	3¾	1	1¾	¼	¾	6¾	8¾	1	1	2¾	2.29
6	S 1 1¼	2.000	¾	¾	6¾	¾-14	1.500	2.000	1-14	1¾-12	1-14	3¾	—	3.50	4.88	¾	3¾	1½	1¾	¼	¾	7¾	9¾	1	1	2¾	2.375

DIMENSIONS / FA TYPE (HEAD RECTANGULAR FLANGE MOUNTING) / NFPA-MF1

Unit : inch

ROUND ROD NON-ROTATING

• Non-rotating rod

Hexagonal rod width across flats

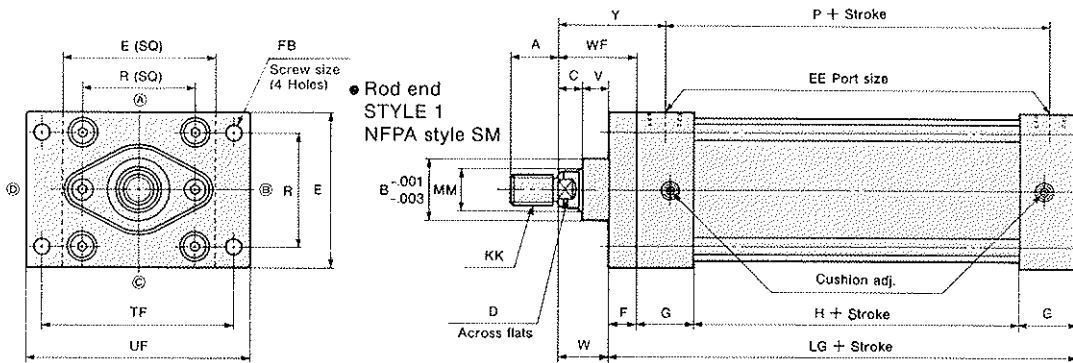
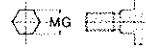

ROD END STYLE (OPTIONAL)

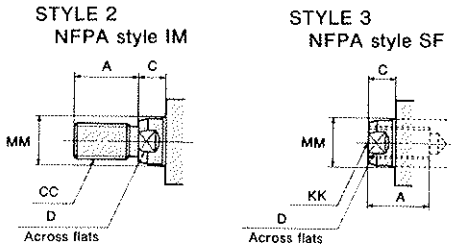

(NOTE)

Regarding to "E" (Rectangular flange) dimension.

In case of position of port ② or ③, "E" dimension is wider than standard flange.

Position of port	Bore size		
	1-1/2	2	3-1/4
Std. ① or ④ "E"	2	2-1/2	3-3/4
Option ② or ③ "E"	2-1/2	3	4-1/4

DIMENSIONAL TABLE

Unit : inch

BORE SIZE	ROD DIA MM	A	B	C	D	E	EE (NPTF)	F	FB	G	H	ROD END STYLE 1	ROD END STYLE 2	ROD END STYLE 3	LG	MG	P	R	TF	UF	V	W	WF	Y
												KK	CC	KK										
1 1/2	S	3/8	1.125	3/8	2	1/8-18	3/8	3/8	1.102	1.421	3/16-20	3/8-20	3/16-20	4	—	2.52	1.43	2 3/8	3 3/8	1/2	3/8	1	1.55	
	M	1	1.500	3/8	2 1/2	1/8-18	3/8	3/8	1.102	1.421	3/16-20	3/8-20	3/16-20	4	.551	2.52	1.84	3 3/8	4 1/8	1/2	3/8	1	1.55	
2	S	1/2	1.125	1/2	3	1/8-18	1/2	1/2	1.102	1.546	3/16-20	1/2-20	3/16-20	4 1/2	.551	2.65	2.19	3 3/8	4 1/8	1/2	3/8	1	1.93	
	M	1	1.500	1/2	3	1/8-18	1/2	1/2	1.102	1.546	3/16-20	1/2-20	3/16-20	4 1/2	—	2.65	2.19	3 3/8	4 1/8	1/2	3/8	1	1.93	
3	S	3/4	1.500	3/4	3 3/4	1/4-14	3/4	3/4	1.417	1.416	3/16-20	3/4-14	3/16-20	4 3/4	.906	2.92	2.76	4 1/8	5 1/8	3/4	3/4	1 1/2	2.04	
	M	1 1/4	2.000	1 1/4	3 3/4	1/4-14	1 1/4	1 1/4	1.417	1.416	1-14	1 1/4-12	1-14	4 3/4	—	2.92	2.76	4 1/8	5 1/8	3/4	3/4	1 1/2	2.29	
4	S	1	1.500	1	4 1/2	1/4-14	1	1	1.417	1.416	3/16-20	1-14	3/16-20	4 3/4	.906	2.92	3.32	5 1/8	6 1/8	3/4	3/4	1 1/2	2.04	
	M	1 1/4	2.000	1	4 1/2	1/4-14	1	1	1.417	1.416	1-14	1 1/4-12	1-14	4 3/4	—	2.92	3.32	5 1/8	6 1/8	3/4	3/4	1 1/2	2.29	
5	S	1 1/4	1.500	1 1/4	5 1/2	1/4-14	1 1/4	1 1/4	1.417	1.666	3/16-20	1-14	3/16-20	5 1/2	.906	3.17	4.10	6 1/8	7 1/8	3/4	3/4	1 1/2	2.04	
	M	1 1/4	2.000	1 1/4	5 1/2	1/4-14	1 1/4	1 1/4	1.417	1.666	1-14	1 1/4-12	1-14	5 1/2	—	3.17	4.10	6 1/8	7 1/8	3/4	3/4	1 1/2	2.29	
6	S	1 1/2	2.000	1 1/2	6 1/2	1/4-14	1 1/2	1 1/2	1.500	2.000	1-14	1 1/4-12	1-14	5 3/4	—	3.50	4.88	7 1/8	8 1/8	3/4	3/4	1 1/2	2.375	

250A-1

DIMENSIONS / FB TYPE (CAP RECTANGULAR FLANGE MOUNTING) / NFPA-MF2

Unit : inch

ROUND ROD NON-ROTATING

• Non-rotating rod

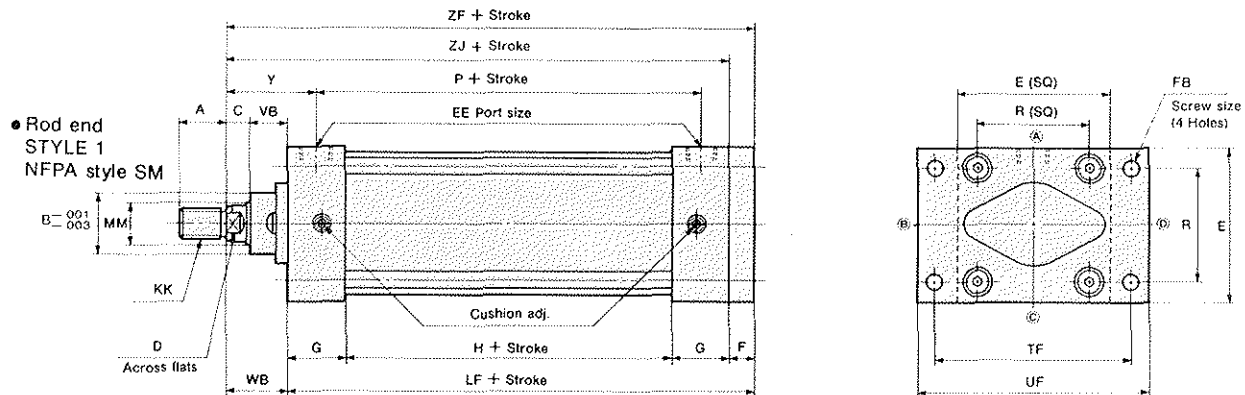
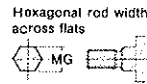

ROD END STYLE (OPTIONAL)

STYLE 2
NFPA style IM

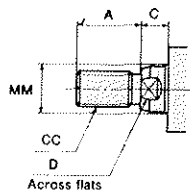

STYLE 3
NFPA style SF

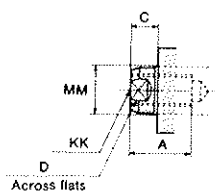

DIMENSIONAL TABLE

Unit : inch

BORE SIZE	ROD DIA MM	A	B	C	D	E	EE (NPTF)	G	H	F	FB	ROD END STYLE 1	ROD END STYLE 2	ROD END STYLE 3	LF	MG	P	R	TF	UF	VB	WB	Y	ZF	ZJ
												KK	CC	KK											
1½	S ¾	¾	1.125	¾	¾	2	¾-18	1.102	1.421	¾	¾	¼-20	¼-20	¼-20	4	—	2.52	1.43	2¾	3¾	¾	1	1.55	5	4¾
	M 1	1	1.500	¾	¾	2½	¾-18	1.102	1.421	¾	¾	¼-20	¼-20	¼-20	4	.551	2.52	1.84	3¾	4¾	¾	1	1.55	5	4¾
2	S 1	1	1.500	¾	¾	2½	¾-18	1.102	1.421	¾	¾	¼-16	¼-14	¼-16	4	—	2.52	1.84	3¾	4¾	¾	1	1.93	5¾	5
	M 1	1	1.500	¾	¾	3	¾-18	1.102	1.546	¾	¾	¼-20	¼-20	¼-20	4¾	.551	2.65	2.19	3¾	4¾	¾	1	1.55	5¾	4¾
2½	S 1½	1½	1.500	¾	¾	3	¾-18	1.102	1.546	¾	¾	¼-16	¼-14	¼-16	4¾	—	2.65	2.19	3¾	4¾	¾	1	1.93	5¾	5
	M 1½	1½	2.000	1	1	3	¾-14	1.417	1.416	¾	¾	1-14	1½-12	1-14	4¾	.906	2.92	2.76	4¾	5¾	¾	1	2.04	6¾	5
3¾	S 2	2	1.500	¾	¾	4	¾-14	1.417	1.416	¾	¾	¾-16	¾-14	¾-16	4¾	.906	2.92	3.32	5¾	6¾	¾	1	2.04	6¾	5
	M 2	2	2.000	1	1	4	¾-14	1.417	1.416	¾	¾	1-14	1½-12	1-14	4¾	—	2.92	3.32	5¾	6¾	¾	1	2.29	6¾	5
4	S 2½	2½	1.500	¾	¾	5	¾-14	1.417	1.666	¾	¾	¾-16	¾-14	¾-16	5	.906	3.17	4.10	6¾	7¾	¾	1	2.04	6¾	5
	M 2½	2½	2.000	1	1	5	¾-14	1.417	1.666	¾	¾	1-14	1½-12	1-14	5	—	3.17	4.10	6¾	7¾	¾	1	2.29	6¾	5
5	S 3	3	2.000	1	1	6	¾-14	1.500	2.000	¾	¾	1-14	1½-12	1-14	5¾	—	3.50	4.88	7¾	8¾	1	1	2.375	7¾	6
	M 3	3	2.000	1	1	6	¾-14	1.500	2.000	¾	¾	1-14	1½-12	1-14	5¾	—	3.50	4.88	7¾	8¾	1	1	2.375	7¾	6

DIMENSIONS / CB TYPE (CAP CLEVIS MOUNTING) / NFPA-MP1

Unit : inch

ROUND ROD NON-ROTATING

• Non-rotating rod

Hexagonal rod width across flats

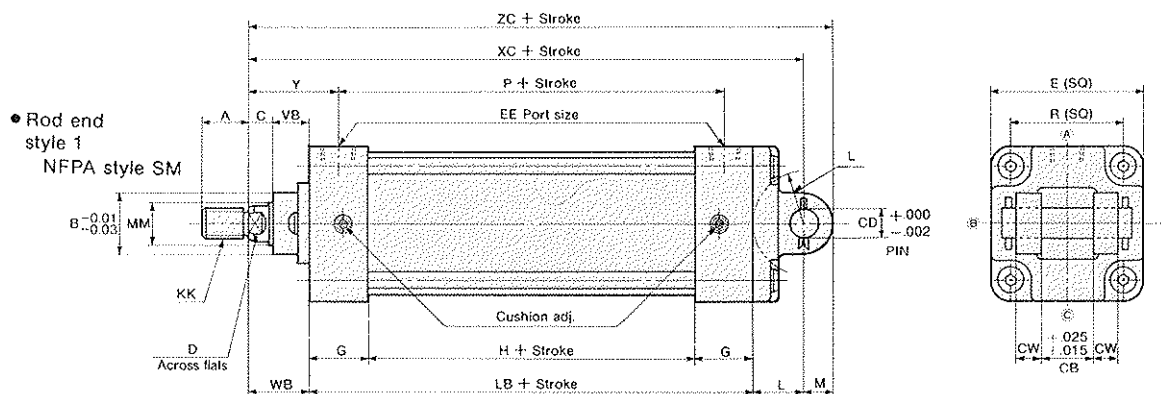
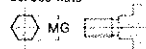

ROD END STYLE (OPTIONAL)

STYLE 2
NFPA style IM

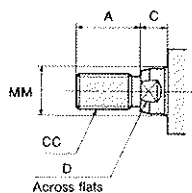

STYLE 3
NFPA style SF

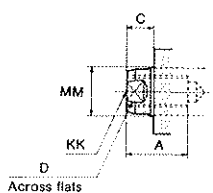

EYE BRACKET

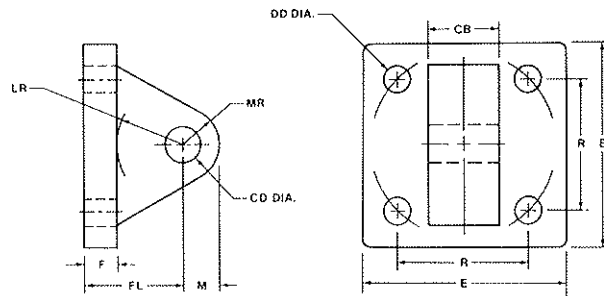

Part No.	CB	CD	DD	E	F	FL	LR	M	MR	R
CA-05	3/4	1/2	13/32	2-1/2	3/8	1-1/8	3/4	1/2	9/16	1.63
CA-07	1-1/4	3/4	17/32	3-1/2	5/8	1-7/8	1-1/4	3/4	7/8	2.56
CA-10	1-1/2	1	21/32	4-1/2	3/4	2-1/4	1-1/2	1	1-1/4	3.25

DIMENSIONAL TABLE

Unit : inch

BORE SIZE	ROD DIA MM	A	B	C	CB	CD	CW	D	E	EE (NPTF)	G	H	ROD END STYLE 1	ROD END STYLE 2	ROD END STYLE 3	L	LB	M	MG	P	R	VB	WB	XC	Y	ZO
													KK	CC	KK											
1 1/2	S	3/8	1.125	3/8	3/8	3/8	3/8	2	3/8-18	1.102	1.421	3/16-20	3/8-20	3/8-20	3/8	3%	3%	—	2.52	1.43	3/8	1	5%	1.55	6	
	M	1	1.500	3/8	3/8	3/8	3/8	2 1/2	3/8-18	1.102	1.421	3/16-20	3/8-20	3/8-20	3/8	3%	3%	.551	2.52	1.84	3/8	1	5%	1.93	6%	
2	S	3/8	1.125	3/8	3/8	3/8	3/8	3	3/8-18	1.102	1.546	3/16-20	3/8-20	3/8-20	3/8	3%	3%	.551	2.65	2.19	3/8	1	5%	1.55	6%	
	M	1	1.500	3/8	3/8	3/8	3/8	3	3/8-18	1.102	1.546	3/16-20	3/8-20	3/8-20	3/8	3%	3%	—	2.65	2.19	3/8	1	5%	1.93	6%	
2 1/2	S	1	1.500	1 1/4	3/8	3/8	3/8	3	3/8-18	1.102	1.546	3/16-20	3/8-20	3/8-20	3/8	3%	3%	.551	2.65	2.19	3/8	1	5%	1.55	6%	
	M	1	1.500	1 1/4	3/8	3/8	3/8	3	3/8-18	1.102	1.546	3/16-20	3/8-20	3/8-20	3/8	3%	3%	—	2.65	2.19	3/8	1	5%	1.93	6%	
3	S	1	1.500	1 1/4	3/8	3/8	3/8	3	3/8-18	1.102	1.546	3/16-20	3/8-20	3/8-20	3/8	3%	3%	.551	2.65	2.19	3/8	1	5%	1.55	6%	
	M	1	1.500	1 1/4	3/8	3/8	3/8	3	3/8-18	1.102	1.546	3/16-20	3/8-20	3/8-20	3/8	3%	3%	—	2.65	2.19	3/8	1	5%	1.93	6%	
3 1/2	S	1	1.500	1 1/4	3/8	3/8	3/8	3	3/8-18	1.102	1.546	3/16-20	3/8-20	3/8-20	3/8	3%	3%	.551	2.65	2.19	3/8	1	5%	1.55	6%	
	M	1	1.500	1 1/4	3/8	3/8	3/8	3	3/8-18	1.102	1.546	3/16-20	3/8-20	3/8-20	3/8	3%	3%	—	2.65	2.19	3/8	1	5%	1.93	6%	
4	S	1	1.500	1 1/4	3/8	3/8	3/8	3	3/8-18	1.102	1.546	3/16-20	3/8-20	3/8-20	3/8	3%	3%	.551	2.65	2.19	3/8	1	5%	1.55	6%	
	M	1	1.500	1 1/4	3/8	3/8	3/8	3	3/8-18	1.102	1.546	3/16-20	3/8-20	3/8-20	3/8	3%	3%	—	2.65	2.19	3/8	1	5%	1.93	6%	
5	S	1	1.500	1 1/4	3/8	3/8	3/8	3	3/8-18	1.102	1.546	3/16-20	3/8-20	3/8-20	3/8	3%	3%	.551	2.65	2.19	3/8	1	5%	1.55	6%	
	M	1	1.500	1 1/4	3/8	3/8	3/8	3	3/8-18	1.102	1.546	3/16-20	3/8-20	3/8-20	3/8	3%	3%	—	2.65	2.19	3/8	1	5%	1.93	6%	
6	S	1	1.500	1 1/4	3/8	3/8	3/8	3	3/8-18	1.102	1.546	3/16-20	3/8-20	3/8-20	3/8	3%	3%	.551	2.65	2.19	3/8	1	5%	1.55	6%	
	M	1	1.500	1 1/4	3/8	3/8	3/8	3	3/8-18	1.102	1.546	3/16-20	3/8-20	3/8-20	3/8	3%	3%	—	2.65	2.19	3/8	1	5%	1.93	6%	

250A-1

DIMENSIONS CD TYPE (CAP CLEVIS MOUNTING) /NFPA-MP2

Unit : inch

ROUND ROD NON-ROTATING

• Non-rotating rod

Hexagonal rod width across flats

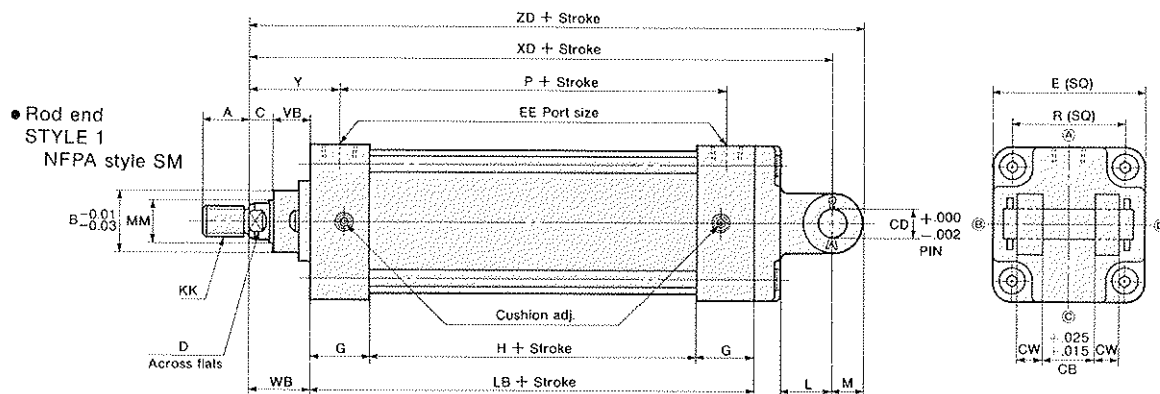
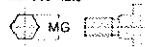

ROD END STYLE (OPTIONAL)

STYLE 2
NFPA style IM

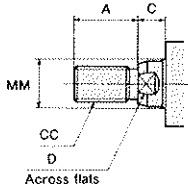

STYLE 3
NFPA style SF

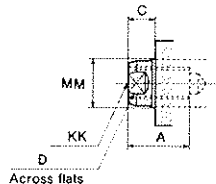

EYE BRACKET

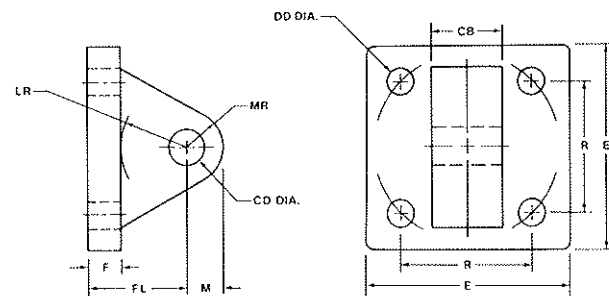

Part No.	CB	CD	DD	E	F	FL	LR	M	MR	R
CA-05	3/4	1/2	13/32	2-1/2	3/8	1-1/8	3/4	1/2	9/16	1.63
CA-07	1-1/4	3/4	17/32	3-1/2	5/8	1-7/8	1-1/4	3/4	7/8	2.56
CA-10	1-1/2	1	21/32	4-1/2	3/4	2-1/4	1-1/2	1	1-1/4	3.25

DIMENSIONAL TABLE

Unit : inch

BORE SIZE	ROD DIA MM	A	B	C	CB	CD	CW	D	E	EE (NPTF)	G	H	ROD END STYLE 1	ROD END STYLE 2	ROD END STYLE 3	L	LB	M	MG	P	R	VB	WB	XD	Y	ZD
													KK	CC	KK											
1 1/2	S 3/8	1.125	3/8	3/8	3/8	3/8	3/8	2	1/8-18	1.102	1.421	1.421	3/16-20	1/8-20	3/16-20	3/8	3/8	—	2.52	1.43	3/8	1	5 1/2	1.55	6 1/2	
	M 1/2	1.500	1/2	1/2	1/2	1/2	1/2	2 1/2	1/8-18	1.102	1.421	1.421	3/16-20	1/8-20	3/16-20	3/8	3/8	.551	2.52	1.84	3/8	1 1/2	6 1/2	1.93	6 1/2	
2 1/2	S 3/8	1.125	3/8	3/8	3/8	3/8	3/8	3	1/8-18	1.102	1.546	1.546	3/16-20	1/8-20	3/16-20	3/8	3/8	.551	2.65	2.19	3/8	1	5 1/2	1.55	6 1/2	
	M 1/2	1.500	1/2	1/2	1/2	1/2	1/2	3	1/8-18	1.102	1.546	1.546	3/16-20	1/8-20	3/16-20	3/8	3/8	—	2.65	2.19	3/8	1 1/2	6 1/2	1.93	6 1/2	
3 1/2	S 1/2	1.500	1/2	1/2	1/2	1/2	1/2	3 1/2	1/8-14	1.417	1.416	1.416	3/16-20	1/8-20	3/16-20	1 1/4	4 1/4	.906	2.92	2.76	3/8	1 1/2	7 1/2	2.04	8 1/2	
	M 1 1/4	2.000	3/4	3/4	3/4	3/4	3/4	3 3/4	1/8-14	1.417	1.416	1.416	1-14	1 1/2-12	1-14	1 1/4	4 1/4	—	2.92	2.76	1	1 1/2	7 1/2	2.29	8 1/2	
4	S 1/2	1.500	1/2	1/2	1/2	1/2	1/2	4	1/8-14	1.417	1.416	1.416	3/16-20	1/8-20	3/16-20	1 1/4	4 1/4	.906	2.92	3.32	3/8	1 1/2	7 1/2	2.04	8 1/2	
	M 1 1/4	2.000	3/4	3/4	3/4	3/4	3/4	4	1/8-14	1.417	1.416	1.416	1-14	1 1/2-12	1-14	1 1/4	4 1/4	—	2.92	3.32	1	1 1/2	7 1/2	2.29	8 1/2	
5	S 1/2	1.500	1/2	1/2	1/2	1/2	1/2	5	1/8-14	1.417	1.666	1.666	3/16-20	1/8-20	3/16-20	1 1/4	4 1/4	.906	3.17	4.10	3/8	1 1/2	7 1/2	2.04	8 1/2	
	M 1 1/4	2.000	3/4	3/4	3/4	3/4	3/4	5	1/8-14	1.417	1.666	1.666	1-14	1 1/2-12	1-14	1 1/4	4 1/4	—	3.17	4.10	1	1 1/2	8	2.29	8 1/2	
6	S 1 1/4	2.000	3/4	3/4	3/4	3/4	3/4	6	1/8-14	1.500	2.000	2.000	1-14	1 1/2-12	1-14	1 1/4	5	1 1/4	—	3.50	4.88	1	1 1/2	8 1/2	2.375	10

DIMENSIONS / CC TYPE (CAP EYE MOUNTING) / NFPA-MP4

Unit : inch

ROUND ROD NON-ROTATING

• Non-rotating rod

Hexagonal rod width across flats

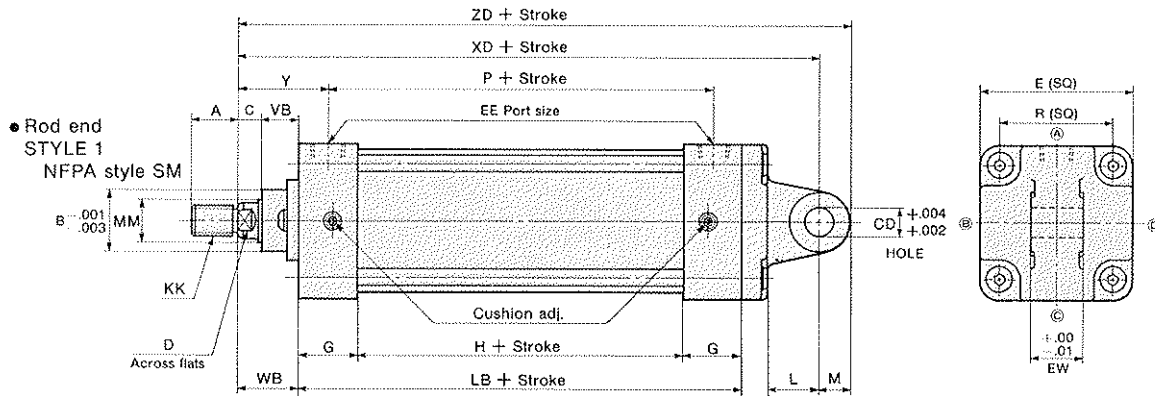
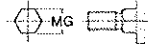

ROD END STYLE (OPTIONAL)

STYLE 2
NFPA style IM

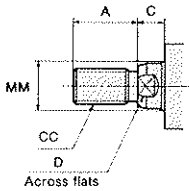

STYLE 3
NFPA style SF

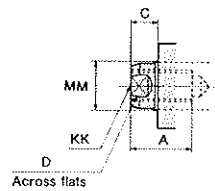

DIMENSIONAL TABLE

Unit : inch

BORE SIZE	ROD DIA MM	A	B	C	CD	D	E	EE (NPTF)	EW	G	H	ROD END STYLE 1	ROD END STYLE 2	ROD END STYLE 3	L	LB	M	MG	P	R	VB	WB	XD	Y	ZD
												KK	CC	KK											
1½	S ¾	¾	1.125	¾	¾	¾	2	¾-18	¾	1.102	1.421	¾-20	¾-20	¾-20	¾	3¾	¾	—	2.52	1.43	¾	1	5¾	1.55	6¾
	M 1	1¾	1.500	¾	¾	¾	2½	¾-18	¾	1.102	1.421	¾-20	¾-20	¾-20	¾	3¾	¾	.551	2.52	1.84	¾	1	5¾	1.55	6¾
2	S ¾	¾	1.125	¾	¾	¾	2	¾-18	¾	1.102	1.421	¾-20	¾-20	¾-20	¾	3¾	¾	—	2.52	1.84	¾	1	5¾	1.55	6¾
	M 1	1¾	1.500	¾	¾	¾	2½	¾-18	¾	1.102	1.421	¾-16	¾-14	¾-16	¾	3¾	¾	—	2.52	1.84	¾	1	6¾	1.93	6¾
2½	S ¾	¾	1.125	¾	¾	¾	3	¾-18	¾	1.102	1.546	¾-20	¾-20	¾-20	¾	3¾	¾	.551	2.65	2.19	¾	1	5¾	1.55	6¾
	M 1	1¾	1.500	¾	¾	¾	3	¾-18	¾	1.102	1.546	¾-16	¾-14	¾-16	¾	3¾	¾	—	2.65	2.19	¾	1	6¾	1.93	6¾
3¾	S 1	1¾	1.500	¾	¾	¾	3¾	¾-14	1¾	1.417	1.416	¾-16	¾-14	¾-16	1½	4¾	¾	.906	2.92	2.76	¾	1	7¾	2.04	8¾
	M 1¾	1¾	2.000	¾	¾	1	3¾	¾-14	1¾	1.417	1.416	1-14	1½-12	1-14	1½	4¾	¾	—	2.92	2.76	1	1	7¾	2.29	8¾
4	S 1	1¾	1.500	¾	¾	¾	4	¾-14	1¾	1.417	1.416	¾-16	¾-14	¾-16	1½	4¾	¾	.906	2.92	3.32	¾	1	7¾	2.04	8¾
	M 1¾	1¾	2.000	¾	¾	1	4	¾-14	1¾	1.417	1.416	1-14	1½-12	1-14	1½	4¾	¾	—	2.92	3.32	1	1	7¾	2.29	8¾
5	S 1	1¾	1.500	¾	¾	¾	5	¾-14	1¾	1.417	1.666	¾-16	¾-14	¾-16	1½	4¾	¾	.906	3.17	4.10	¾	1	7¾	2.04	8¾
	M 1¾	1¾	2.000	¾	¾	1	5	¾-14	1¾	1.417	1.666	1-14	1½-12	1-14	1½	4¾	¾	—	3.17	4.10	1	1	8	2.29	8¾
6	S 1¾	1¾	2.000	¾	1	1	6	¾-14	1¾	1.500	2.000	1-14	1½-12	1-14	1½	5	¾	—	3.50	4.88	1	1	8	2.375	9¾

250A-1

DIMENSIONS / TC TYPE (INTERMEDIATE FIXED TRUNNION MOUNTING) / NFPA-MT4

Unit : inch

ROUND ROD NON-ROTATING

• Non-rotating rod

Hexagonal rod width across flats

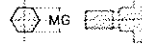

• Rod end STYLE 1 NFPA style SM

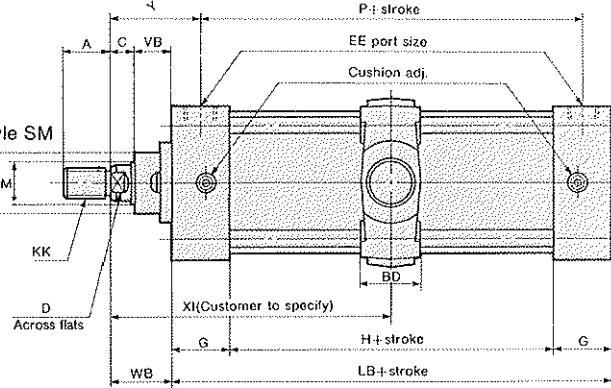

ROD END STYLE (OPTIONAL)

STYLE 2 NFPA style IM

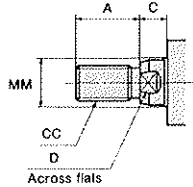

STYLE 3 NFPA style SF

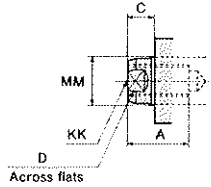

Note: TC Mounting – Not Available with Six Inch Bore

DIMENSIONAL TABLE

Unit : inch

BORE SIZE	ROD DIA MM	A	B	BD	C	D	E	EE (NPTF)	G	H	ROD END STYLE 1	ROD END STYLE 2	ROD END STYLE 3	LB	MG	P	R	TD	TL	TM	UM	VB	WB	Y	XI
											KK	CC	KK												
1½	¾	¾	1.125	1⅞	¾	½	2	¾-18	1.102	1.421	⅞-20	½-20	⅞-20	3%	—	2.52	1.43	1	1	2½	4½	¾	1	1.55	
	1	1½	1.500	1⅞	¾	¾	2½	¾-18	1.102	1.421	¾-16	¾-14	¾-16	3%	—	2.52	1.84	1	1	3	5	¾	1½	1.93	
2	¾	¾	1.125	1⅞	¾	½	3	¾-18	1.102	1.546	⅞-20	½-20	⅞-20	3%	.551	2.65	2.19	1	1	3½	5½	¾	1	1.55	
	1	1½	1.500	1⅞	¾	¾	3	¾-18	1.102	1.546	¾-16	¾-14	¾-16	3%	—	2.65	2.19	1	1	3½	5½	¾	1½	1.93	
3	1	1½	2.000	1⅞	¾	1	3	¾-14	1.417	1.416	1-14	1½-12	1-14	4%	.906	2.92	2.76	1	1	4½	6½	¾	1½	2.04	
	1½	2	2.000	1⅞	¾	1½	3	¾-14	1.417	1.416	1-14	1½-12	1-14	4%	—	2.92	2.76	1	1	4½	6½	1	1½	2.29	
4	1	1½	1.500	1⅞	¾	¾	4	¾-14	1.417	1.416	¾-16	¾-14	¾-16	4%	.906	2.92	3.32	1	1	5½	7½	¾	1½	2.04	
	1½	2	2.000	1⅞	¾	1	4	¾-14	1.417	1.416	1-14	1½-12	1-14	4%	—	2.92	3.32	1	1	5½	7½	1	1½	2.29	
5	1	1½	1.500	1⅞	¾	¾	5	¾-14	1.417	1.666	¾-16	¾-14	¾-16	4%	.906	3.17	4.10	1	1	6½	8½	¾	1½	2.04	
	1½	2	2.000	1⅞	¾	1	5	¾-14	1.417	1.666	1-14	1½-12	1-14	4%	—	3.17	4.10	1	1	6½	8½	1	1½	2.29	

CUSTOMER TO SPECIFY

ACCESSORIES

ROD END EYE (TYPE-T)

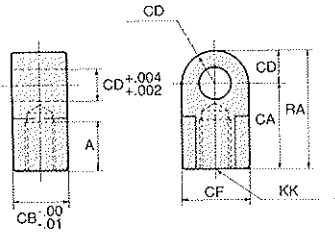

DIMENSIONAL TABLE

PART No.	A	CA	CB	CD	CF	ER	KK	RA
T-1	3/4	1 1/2	3/4	1/2	1	.63	7/16-20	2
T-2	1 1/8	2 1/8	1 1/4	3/4	1 1/2	.87	3/4-16	2 13/16
T-3	1 1/2	2 3/4	1 1/2	1	2	1.18	1-14	3 13/16

* For Rod End Style 1.

ROD END CLEVIS (TYPE-Y)

Unit : inch

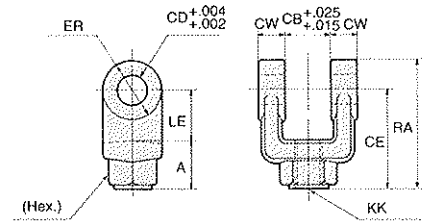

DIMENSIONAL TABLE

PART No.	A	CE	CB	CD	CW	ER	KK	LE	RA
Y-1	3/4	1 1/2	3/4	1/2	1/2	1/2	7/16-20	3/4	2
Y-2	1 1/8	2 1/8	1 1/4	3/4	3/4	3/4	3/4-16	1 1/4	3 3/8
Y-3	1 1/2	3 3/8	1 1/2	1	1	1	1-14	1 1/2	4 1/4

* For Rod End Style 1.

SPHERICAL ROD EYES

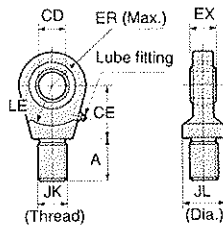

DIMENSIONAL TABLE

PART No.	A	CD	CE	ER	EX	JK	JL	LE
SR-500	1 1/16	.5000-.0005	3/8	3/8	3/16	7/16-20	3/8	3/4
SR-750	1	.7500-.0005	1 1/4	1 1/4	2 1/32	3/4-16	1 1/16	1 1/16
SR-1000	1 1/2	1.000-.0005	1 7/8	1 3/8	3/4	1-14	1 1/2	1 7/8

SELF-ALIGNING ROD END COUPLER

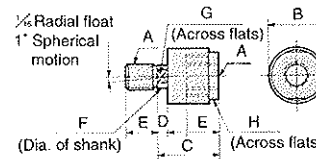

DIMENSIONAL TABLE

PART No.	THREAD	B	C	D	E	F	G	H	MAX PULL AT YIELD
AC-437	7/16-20	1.25	2.00	0.50	0.75	0.62	0.50	1.00	10,000
AC-750	3/4-16	1.75	2.31	0.50	1.12	0.97	0.81	1.50	34,000
AC-1000	1-14	2.50	2.94	0.50	1.62	1.38	1.16	2.25	64,000

PIVOT PIN (Includes Cotter Pins)

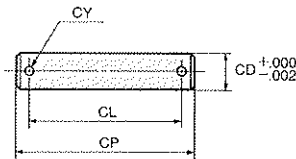

DIMENSIONAL TABLE

PART No.	CD	CL	CP	CY
P-1	3/8	2	2 1/2	3/16
P-2	3/4	2 3/4	3 1/4	3/16
P-3	1	3 1/4	3 3/4	3/16

LOCK NUT

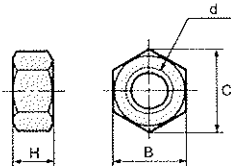

DIMENSIONAL TABLE

PART No.	d	B	C	H
LN-1	7/16-20	1 1/16	.79	3/8
LN-2	3/4-20	3/4	.87	3/8
LN-3	3/4-16	1 1/8	1.30	2 1/16

STUD BOLT

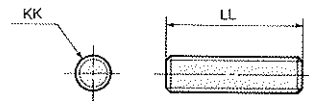

DIMENSIONAL TABLE

PART No.	KK	LL
SB-1	7/16-20	1 1/2
SB-2	3/4-16	2 1/4
SB-3	1-14	3 1/4

250A-1

SWITCH SET OPERATION AND HANDLING (MAGNETIC PROXIMITY TYPE)

STRUCTURE AND OPERATION

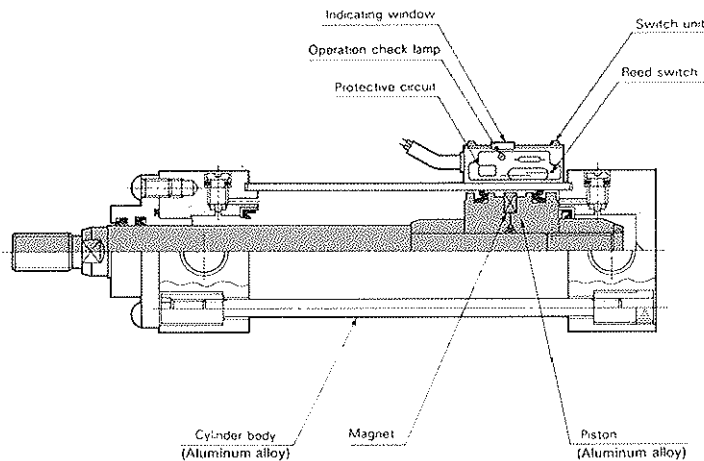

DESCRIPTION

The magnetic proximity switches mounted on the cylinder body (aluminum tube) contain a reed switch, a protective circuit and an operation check lamp, all potted in plastic. The reed switch actuates when the magnet integrated in the piston passes below. This allows detection of the position of the cylinder piston.

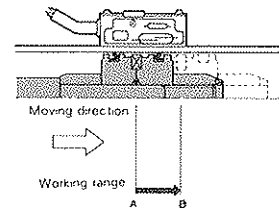

When the piston moves in the \rightarrow direction and arrives at position A, the reed switch actuates. The switch remains on from A to B. This is called the working range.

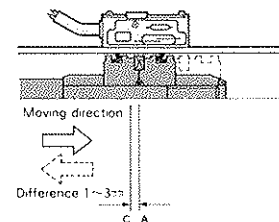

When the piston reaches position A and then returns in the reverse direction \leftarrow , the switch remains on until the piston reaches C. The interval between A and C is called the difference.

HOW TO SET SWITCH DETECTING POSITION AND TO CONFIRM OPERATION

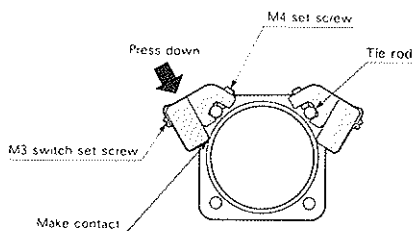

BEFORE MOVEMENT

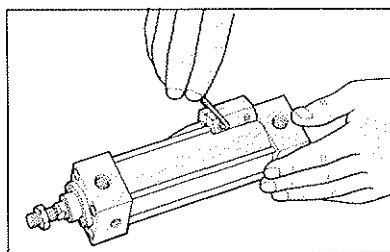

AFTER MOVEMENT

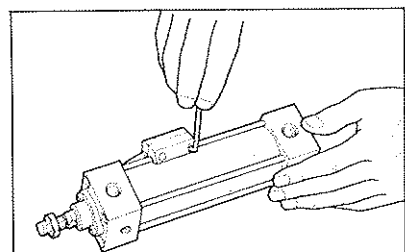

1. Slide switch on the tie rod after loosening two set screws with an Hexagon Wrench Keys 5/64"(2 mm).
2. At the desired position, gently press down on the top of the switch, hold the switch detection face against the cylinder body, and tighten the set screws.
3. The indicator lamp will go on (DC) or off (AC) when the switch actuates.
4. Switches can be mounted on any tie rod, at the position which best suits the cylinder installation space and the wiring method.

SWITCH SETTING POSITION

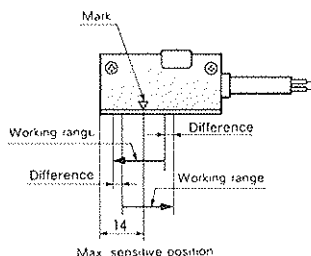

The point of maximum switch sensitivity (marked ∇) is 55" (14mm) from the switch end. The switch goes on when the piston magnet enters the working range, whose center is this point. (The difference varies depending on the direction of piston movement.)

HANDLING INSTRUCTIONS OF CYLINDER WITH SWITCH

CAUTIONS

1. Be careful not to exceed rated voltage, current and load capacity.
2. Do not connect power source directly with switch, but to a certain load; such as a relay or sequencer.
3. If positioning switch at intermediate position on the tube, make sure maximum cylinder speed does not exceed 10 in/sec with regard to relay response time.
4. Proper current must be supplied to switch, for confirming lamp to operate correctly.
5. When AC-type switches (SR30*, SR40*) are connected in parallel arrangement, signal is given, but confirming lamp will not light normally.
Current leakage will increase in conjunction with the number of switches during un-switching operation.
6. When DC-type switches (SR10*, SR20) are connected in series, a high degree of voltage drop will result due to internal resistance of switches.
7. Do not place magnetic substance around cylinder body and switch.
8. In an environment where a strong magnetic field is present, protect cylinder with a shield plate.

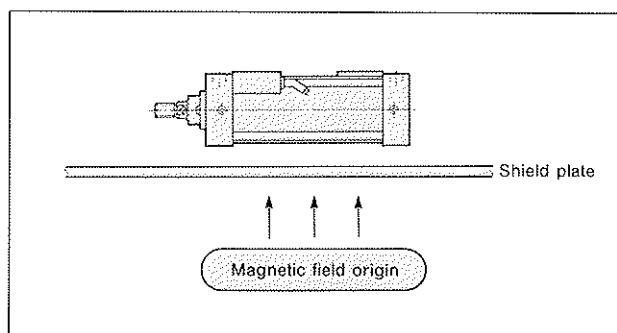

9. If a coil is used in conjunction power usage, a voltage surge may originate. Thus, a protective circuit must be arranged in parallel in order to protect switch.

• SR400•SR401•SR405

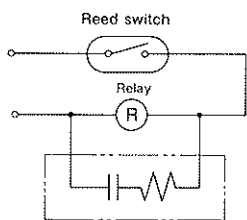

• SK-100

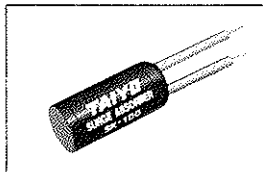

protective circuit (SK-100)

WIRING SWITCHES WITH SOCKETS

Socket directions and sheath stripping dimensions

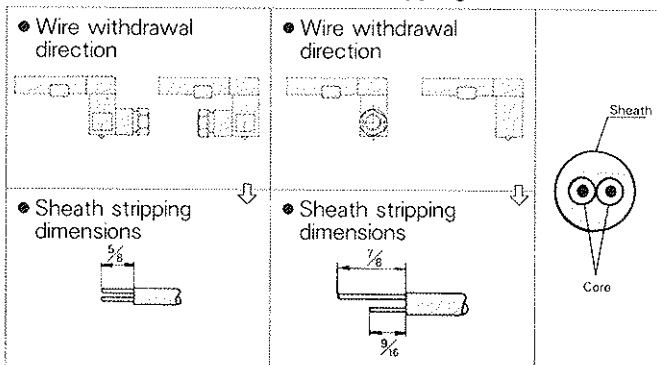

Note: Strip only sheath. Do not strip inner core wires.

APPLICABLE WIRE

Wire name	Applicable wire		
	Conductor	Core	Overall diameter
Vinyl cabtyre wire (VCTF) (JIS C3322)	(0.75mm ²)	2 core	$\frac{3}{32}$ (φ6.8~φ7.2mm)

INSTALLATION

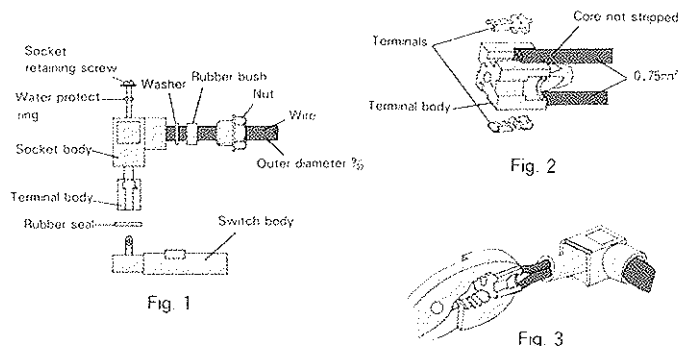

PROCEDURE

1. Loosen the socket retaining screw, and remove the socket from the reed switch.
2. Keep turning the socket retaining screw, and remove the socket body from the terminal body.
3. Strip sheath so that core wires are as shown in the above diagram (Socket directions and sheath stripping dimensions).
4. Insert wire as shown in Fig. 1.
5. Remove the terminal from the terminal body. (There are three terminals, but use only #2 and #3 which are opposed to each other.) Slide core wires into the terminal body as shown in Fig. 2.
6. As shown in Fig. 3, clamp core wires in the terminal with pliers.
7. While pulling the wire, insert the terminal body in the socket body.
8. Fasten the terminal body to the socket body with the socket retaining screw. Then fasten the socket to the switch. (Be sure to fasten with the switch pins inserted in #2 and #3 of the socket.)

250A-1

CUSHIONING ADJUSTMENT

Cushioning is adjusted prior to shipment from the factory, but the cushion effect may change due to cylinder speed, load and inertial force.

When necessary, adjust the cushion needle as follows.

Turn cushion needle to the left or right, and adjust speed at stroke end so that shock is minimal and operation smoothness is optimal.

Turning to the left (right) opens (closes) the cushion needle.

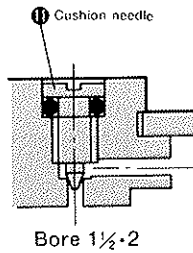

WARNING

DO NOT LOOSEN SCREW MORE THAN 2 TURNS FROM SEATED POSITION.
(1 1/2", 2" Bore Size Only)

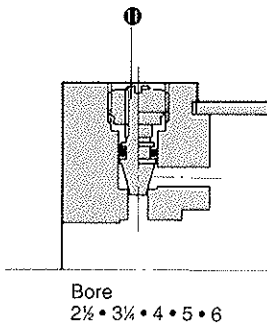

RANGE OF SHOCK ABSORPTION POSSIBLE WITH CUSHIONING

The cushioning mechanism decreases piston speed by applying backpressure in the interval of about 3/4" from stroke end (interval length varies depending on bore). Therefore, beware of the mechanism's limitations, shown in the graph below.

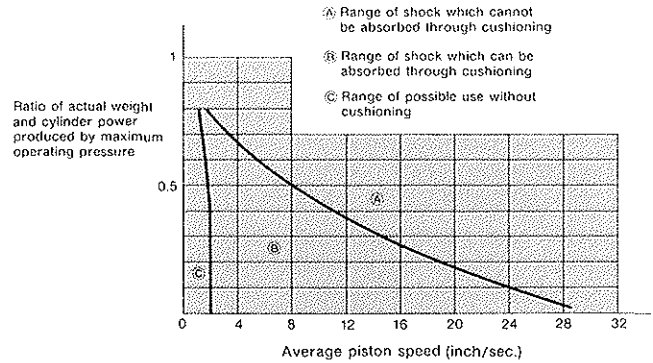

CYLINDER SPEED ADJUSTMENT

Maximum cylinder operating speed is 28 inch/sec. If this speed is exceeded, the rod gland and seals will wear rapidly and the shock at stroke end will increase. The result is shortened cylinder life and susceptibility to malfunction.

If cylinder speed is too low, the result will be sticking, slipping and unstable operation.

Cylinder speed varies depending on pipe diameter, air pressure, flow rate and load, and therefore must be adjusted to suit the intended use. Adjustment is normally done using a speed control valve, but this is not always enough, and other factors may have to be considered (air pressure, load etc.)

TIGHTENING TORQUE FOR TIE ROD NUT (ea)

Bore / inch	1 1/2	2 • 2 1/2	3 1/2 • 4	5 • 6
Tie rod thread	1/4-28	5/16-24	3/8-24	1/2-20
Tightening torque FT • LBS	3	7	15	27

WARNING

AIRPRO AIR CYLINDERS ARE INTENDED FOR USE IN INDUSTRIAL COMPRESSED AIR SYSTEMS ONLY. THEY MUST NOT BE USED WHERE PRESSURE OR TEMPERATURE MAY EXCEED MAXIMUM RATED OPERATING CONDITIONS. SEE SPECIFICATIONS.

IN LUBRICATION APPLICATIONS, SOME OIL MIST MAY ESCAPE FROM THE POINT OF USE INTO THE SURROUNDING ATMOSPHERE. USERS ARE REFERRED TO OSHA SAFETY AND HEALTH STANDARDS FOR LIMITING OIL MIST CONTAMINATION AND UTILIZATION OF PROTECTING EQUIPMENT.

IN AUTO SWITCH (MAGNETIC PROXIMITY SWITCH) APPLICATIONS, BE SURE TO CONNECT THE AUTO SWITCH TO THE POWER SOURCE THROUGH A LOAD. DIRECT CONNECTION OF THE SWITCH MAY CAUSE DAMAGE TO THE INTERNAL ELEMENTS OF THE SWITCH.

WARRANTY

AIRPRO 250A-1 SERIES CYLINDERS ARE WARRANTED FOR (3) YEARS TO BE FREE FROM DEFECTS IN WORKMANSHIP AND MATERIAL. TAIYO WILL REPLACE, FREE OF CHARGE INCLUDING LOWEST TRANSPORTATION COSTS, BUT NOT INCLUDING INSTALLATION OR ANY OTHER CHARGES, ANY PART THAT TAIYO'S INSPECTION SHOWS TO BE DEFECTIVE. ALL DEFECTIVE PARTS MUST BE RETURNED TO TAIYO'S PLANT WITHIN GUARANTEE PERIOD AFTER SHIPMENT BY TAIYO. WRITTEN PERMISSION FOR SUCH RETURN MUST FIRST BE OBTAINED.

A COMPLETE EXPLANATION IS REQUIRED OF THE DEFECTS AND CIRCUMSTANCES. THIS WARRANTY APPLIES ONLY IF GOODS FAIL TO FUNCTION PROPERLY UNDER CORRECT USE, NORMAL OPERATING CONDITIONS, AND PROPER APPLICATION BECAUSE OF DEFECTS IN MATERIAL OR WORKMANSHIP, AND IF TAIYO IS NOTIFIED PROMPTLY IN WRITING OF SUCH FAILURE. IF GOODS ARE IN ACCORDANCE WITH OR IN REFERENCE TO AN ENGINEERING DRAWING SPECIFIED BY OR FURNISHED TO THE CUSTOMER. THESE SPECIFICATIONS AND INFORMATION SHALL BE APPLICABLE IN DETERMINING SUCH CORRECT USE, OPERATION AND APPLICATION.

TAIYO MAKES NO WARRANTY THAT THE GOODS ARE DELIVERED FREE OF THE RIGHTFUL CLAIM OF ANY THIRD PERSON BY WAY OF INFRINGEMENT OR THE LIKE. THERE ARE NO WARRANTIES OF MERCHANTABILITY, OF FITNESS FOR A PARTICULAR PURPOSE OR ORDINARY PURPOSE, NOTWITHSTANDING ANY DISCLOSURE TO TAIYO FOR THE USE TO WHICH THE PRODUCTS IS TO BE PUT.

TAIYO SHALL NEVER BE LIABLE FOR ANY CONSEQUENTIAL OR INCIDENTAL DAMAGES. THE SALE OF TAIYO'S PRODUCTS UNDER ANY OTHER REPRESENTATION, WARRANTY OR GUARANTEE, EXPRESS OR IMPLIED IS NOT AUTHORIZED BY TAIYO.

1702 East Spring St, St. Marys, OH 45885

Phone: 1-877-544-8775

Fax: 1-419-300-9765

Phone: 1-630-823-8598

Phone: 1-502-370-4142

Phone: 1-419 -300-8811

Phone: 1-615-907-3355