

PROPORTIONAIR

DS & WT SERIES PRESSURE TRANSDUCERS

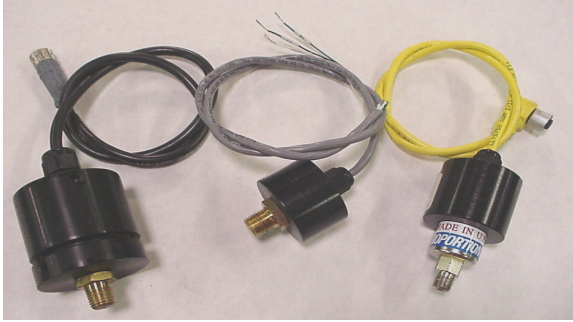

- ◆ Wide pressure ranges available
- ◆ Adjustable zero and span
- ◆ Available with voltage or current outputs
- ◆ Rugged anodized aluminum housing
- ◆ Stainless steel sensor option
- ◆ NEMA4 option

DESCRIPTION

DS series pressure transducers accurately measure pressure of gases or fluids. The output is an electrical signal based on the measurement.

Conditioning of the electrical signal from the strain gauge sensor gives either 0-10 VDC or 4-20 mA output depending on the model ordered (consult factory for other available outputs). The electrical output is a linear ratio of the pressure sensed. DS series transducers are enclosed in a rugged aluminum housing. A strain relief protects the wiring from damage caused by excessive pulling force.

The standard version (DS) measures pressure using a piezoresistive semiconductor sensor chip.

The stainless steel version (DST) utilizes the same silicon etched device mounted on a stainless steel diaphragm. On these units, no elastomers or o-rings contact the pressurized media. All media wetted parts are ANSI type 316L stainless steel.

The NEMA4 version (WT series) is electrically identical to the DS series. The WT series is housed in a slightly larger canister that is sealed against fluid spray from any direction.

WT SERIES

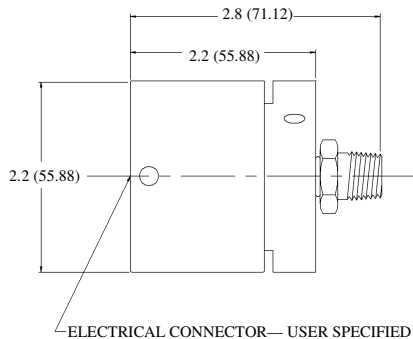

DIMENSIONS

DS SERIES

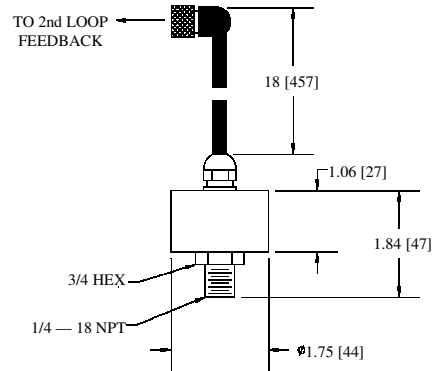

DST SERIES (Old Style)

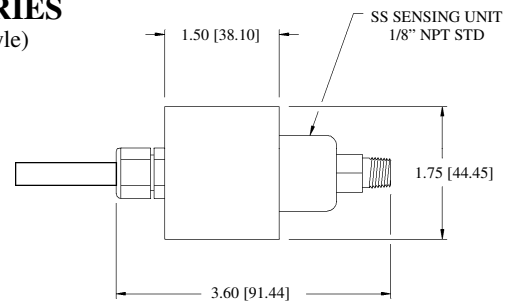

DST SERIES (New Style)

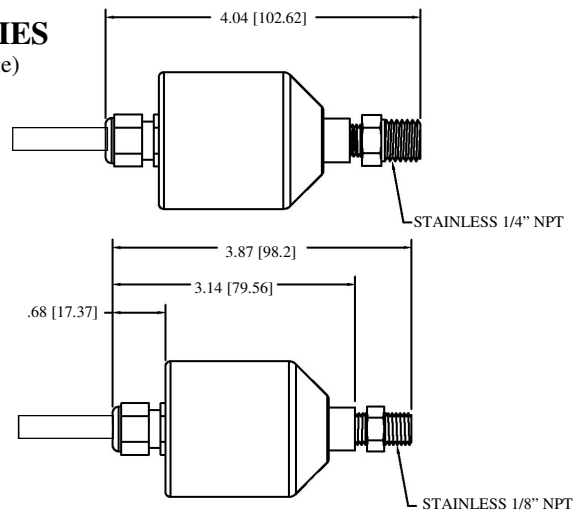

SPECIFICATIONS

<u>ELECTRICAL</u>	<u>MIN</u>	<u>TYP</u>	<u>MAX</u>	<u>TERM</u>
Supply Voltage	15	—	24	VDC
Supply Current				
DSZ, DSX, DSTX, DSTVX, DSY, DSTY, DSTVY, WTE	35	—	50	mA
DSI, DSTI, DSTVI, WTI	4	—	20	mA
Analog Output				
DSX, DSTX, DSTVX, DSY, DSTY, DSTVY, WTE	0	—	10	VDC
DSI, DSTI, DSTVI, WTI	4	—	20	mA
DSZ	1.8	—	9.1	VDC
<u>PERFORMANCE*</u>				
Pressure Ranges*				
DS & WT Series:	-14.7 (-1)	—	300 (21)	Psi (bar)
DST Series:	-14.7 (-1)	—	7200 (496)	Psi (bar)
Response Time:	—	100	—	Microseconds
Repeatability				
DS & WT Series:	—	+/-0.02	—	%F.S.
DST Series:	—	+/-0.25	—	%F.S.
Accuracy				
DS & WT Series:	—	+/-0.2	—	%F.S.
DST Series:	—	+/-0.5	—	%F.S.
Operation Temp.:	32 (0)	—	158 (70)	° F (°C)
Calibration Temp. Effect:		Zero and span adjustable <1% over specified tem. Range (0-50°C , 122° F)		
<u>PHYSICAL</u>				
Weight				
WT Series:		11.2 (318)		oz (g)
DS Series:		4.8 (136)		oz (g)
DST Series:		5.4 (154)		oz (g)
Materials				
Seals:		DS & WT Series– Viton DST Series– 316L ss		
Housing:		Anodized Aluminum		
Fitting:		DS & WT Series– 360 FC Brass DST Series– 316 L ss		
Media				
DS & WT Series:		Non corrosive gases		
DST Series:		Non corrosive fluids & gases		
Shock		100 G's of force		
* Max range available, see model number for individual ranges available.				

CALIBRATION PROCEDURE

The WT, DS & DST series pressure transducers are factory calibrated. Should further calibration be required, please follow these procedures.

Two calibration potentiometers on the pressure transducer set the overall zero and span points. They are located on the back of the transducer recessed in two holes.¹ (See figure 1 for location) These adjustments are set by the factory and covered with metallic tape. This metal tape may be removed to recalibrate the unit.¹

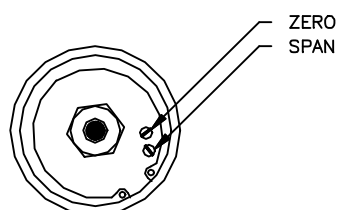

Figure 1

*You must have a good understanding of what the span and zero set adjustments do before changing them.

Step #1: Remove the metal tape¹ from the transducer lid to expose screwdriver slot adjustments of the calibration potentiometers.

Step #2: Make correct electrical connection for the model of transducer being calibrated. (see “ELECTRICAL CONNECTION” on this document for proper wiring).

Step #3: Apply the maximum desired pressure to the pressure port.

Step #4: Turn the span adjustment to set the maximum desired electrical output signal.

Step #5: Apply the minimum desired pressure to the pressure port. If the minimum desired pressure is zero, then use a setting equal to 10% of the maximum desired pressure.

Step #6: Turn the zero adjustment to set the minimum desired electrical output signal. If using 10% of the maximum desired pressure, then set the minimum electrical output signal to be 10% of the maximum desired electronic output signal. (ie: 5.6mA for a 4-20mA device).

Step# 7: Repeat steps #3-#6 until accuracy specifications of the device are met.

¹ In the WT Series, you must remove the lid.

ELECTRICAL CONNECTION

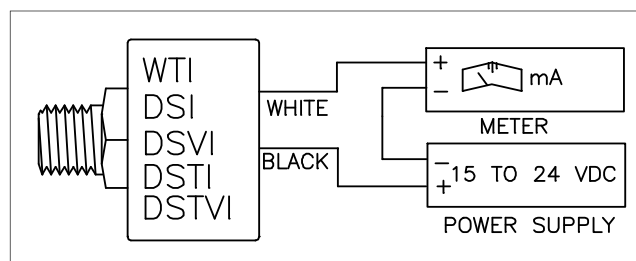
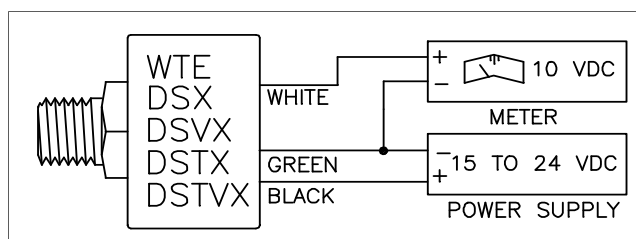
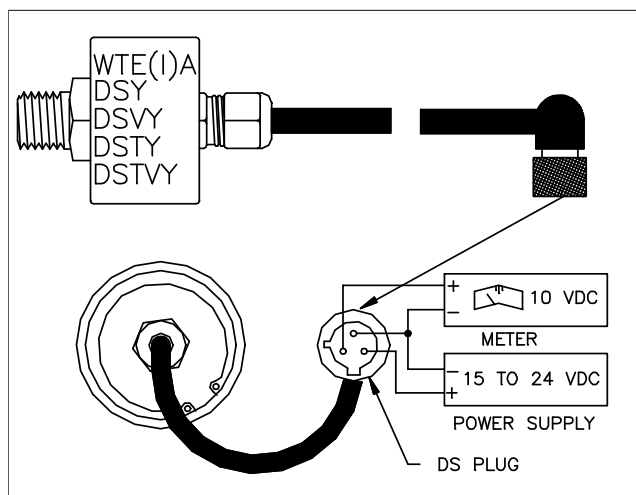

DS & WT SERIES ORDERING INFORMATION

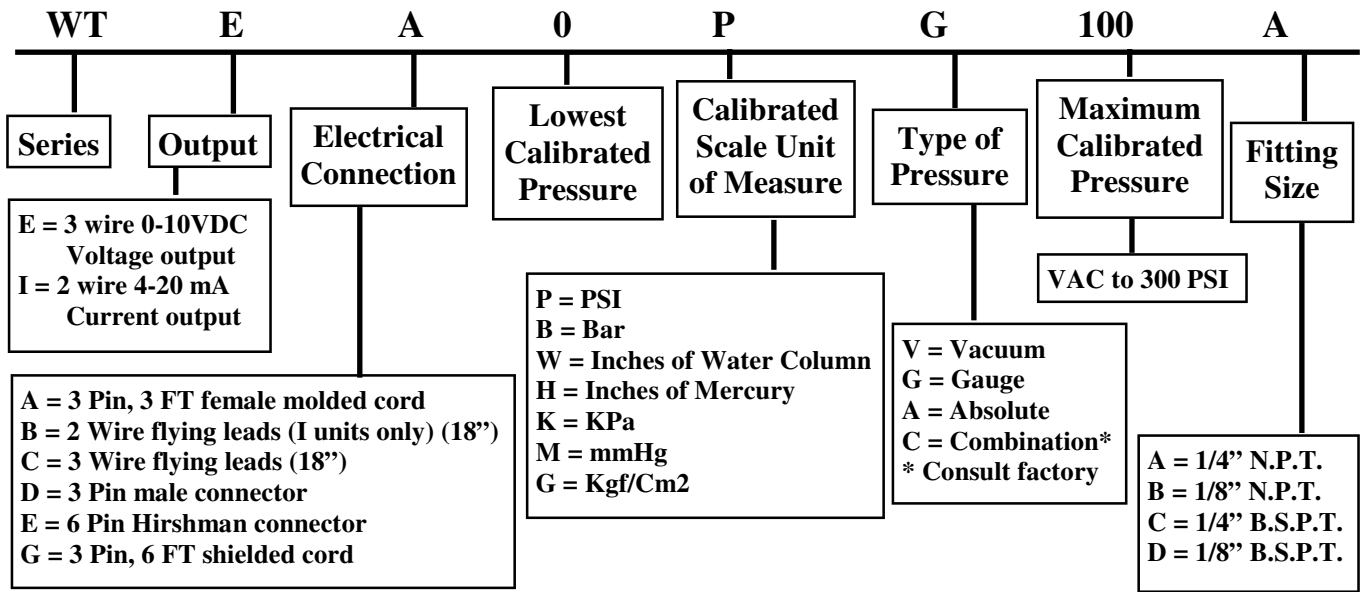
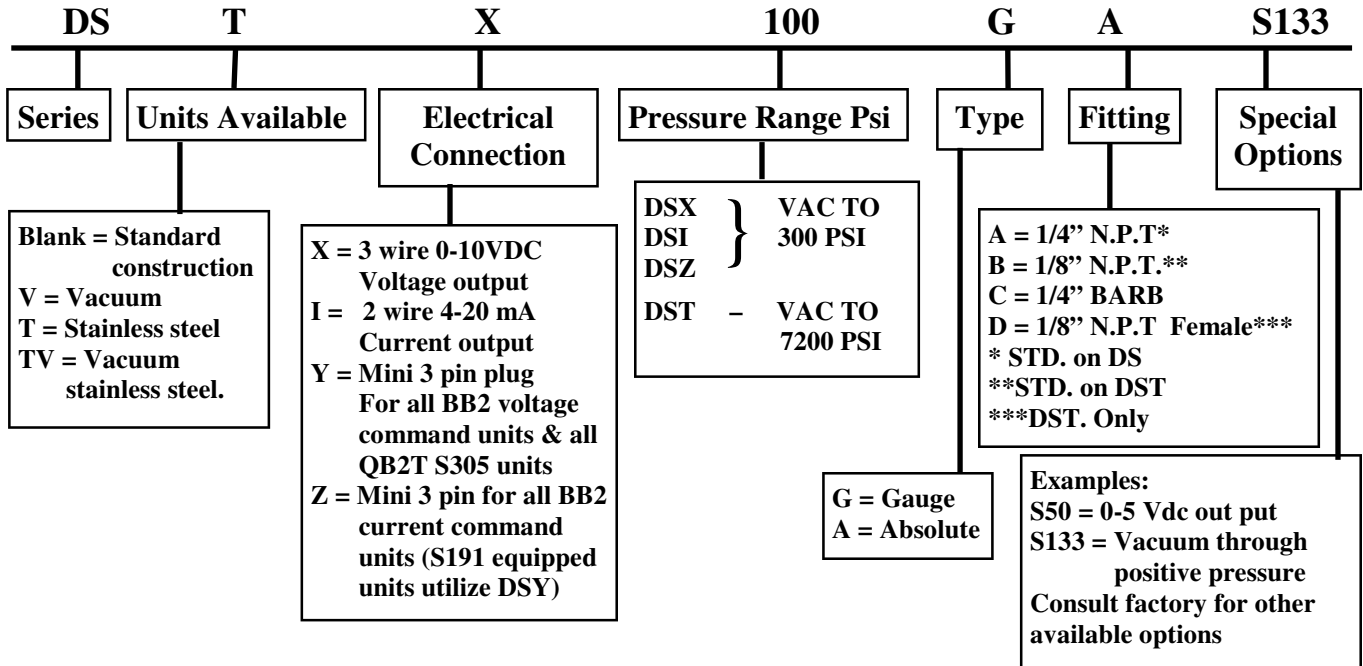

Proportion-Air products are warranted to the original purchaser only against defects in material or workmanship for one (1) year from the date of manufacture. The extent of Proportion-Air's liability under this warranty is limited to repair or replacement of the defective unit at Proportion-Air's option. Proportion-Air shall have no liability under this warranty where improper installation or filtration occurred.

All specifications are subject to change without notice. **THIS WARRANTY IS GIVEN IN LIEU OF, AND BUYER HEREBY EXPRESSLY WAIVES, WARRANTIES OR LIABILITIES, EXPRESS, IMPLIED OR STATUTORY, INCLUDING WITHOUT LIMITATION ANY OBLIGATION OF PROPORTION-AIR WITH REGARD TO CONSEQUENTIAL DAMAGES, WARRANTIES OF MERCHANTABILITY, DESCRIPTION, AND FITNESS FOR A PARTICULAR PURPOSE.**

WARNING: Installation and use of this product should be under the supervision and control of properly qualified personnel in order to avoid the risk of injury or death.

PROPORTION-AIR, INC.
BOX 218 MCCORDSVILLE, IN USA 46055
PHONE: (317)335-2602 **FAX: (317)335-3853**
web site: www.proportionair.com **email address: info@proportionair.com**