

VACUUM VALVES

INTRODUCTION

Vacuum Valves control the flow of vacuum for material handling or process control where other mechanical methods may not be suitable. Various Humphrey valves may be used for vacuum but the poppet and diaphragm poppet designs shown below offer unique advantages versus competitive models that are not specifically modified for vacuum use.

The advantages of vacuum valves are the following:

- Poppet design offers small Direct-Operating Solenoid Valves requiring no air or vacuum pilot.
- Diaphragm poppet design offers unique construction that uses the vacuum to assist sealing resulting in a condition where the higher the vacuum the tighter the valve's seal.

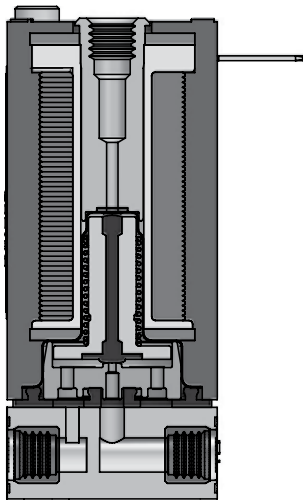

B3E1 - Poppet Valve

VACUUM VALVE FEATURES:

- Small Size – mount close to work.
- No Lubrication.
- Contamination tolerant.
- No sliding seals.
- No sticking.
- Full orifice.
- Multi media/vacuum and air/gas.
- Various types of actuation.

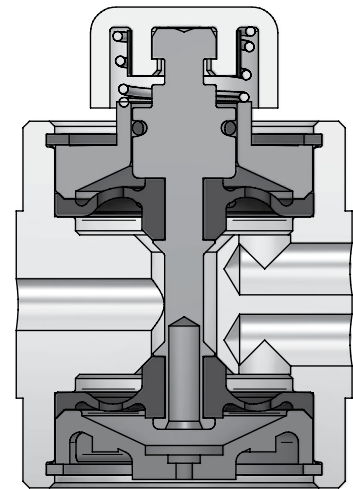

V250P - Diaphragm Poppet Valve

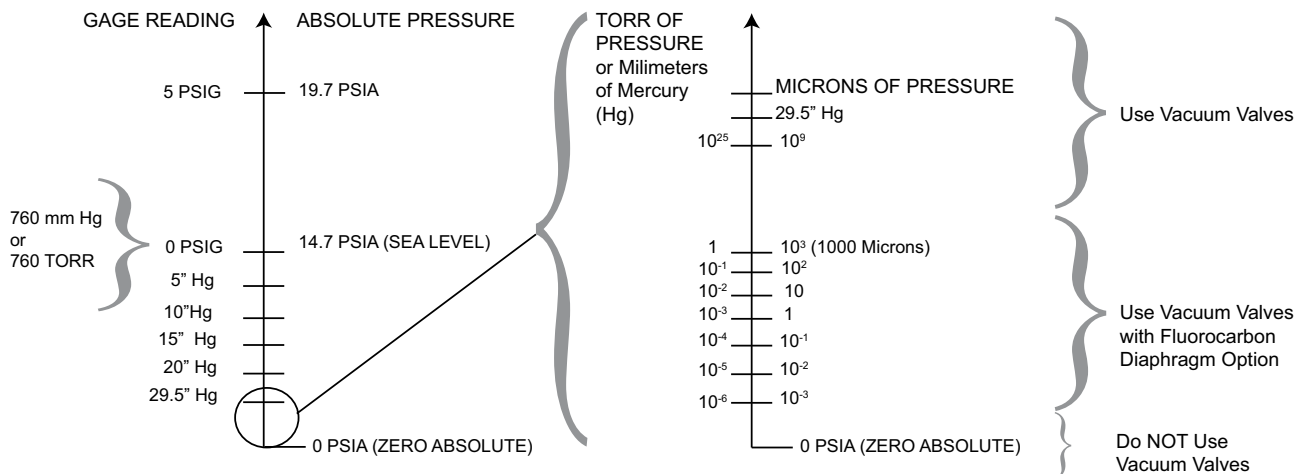

GENERAL VACUUM INFORMATION

SOLENOID 2-, 3-WAY VALVES		Ports	Valves	Page
SMALL	Mini Mizer Series	10-32	B3E1-11, MB3E1-11	76-77
	HK5 Series	10-32	HK5, HKL5	76-77
	310 Series	1/8	V310, SV310, MV310	76-77
	Tyna Myte 062 Series	1/4	V062E1, VT062E1	76-77
LARGE	320 Series	1/4	320	76-77
	250 Series	1/4	VA250AE1(2), VV250AE1	78-79
	500 Series	1/2	VA500AE1(2), VV500AE1	78-79
	590 Series	3/4	VA590AE1(2), VV590AE1	78-79
AIR-PILOT 2-, 3-WAY VALVES		Ports	Valves	Page
SMALL	125 Series	1/8	VA125A, VV125A	80-81
	250 Series	1/4	VA250A, VV250A	80-81
LARGE	500 Series	1/2	VA500A, VV500A	80-81
	590 Series	3/4	VA590A, VV590A	80-81
MANUAL/MECHANICAL 2-, 3-WAY VALVES		Ports	Valves	Page
SMALL	125 Series	1/8	V125P, V125HO, V125B	82-83
	250 Series	1/4	V250P, V250C	82-83
LARGE	500 Series	1/2	V500C	82-83



Direct-Acting Solenoid Vacuum Valves

MINI MIZER B3E1, HK5, V310, V062E1, VT062E1, 320, HG010

Most Humphrey Direct-Acting 3-way Valves work reliably as vacuum valves. For those models, no "vacuum service" call out is required. Thus, features and benefits of many models listed here can be found in the Direct-Acting Valves section of this catalog.

Humphrey model V310 and V062 are the exceptions. Mini Mizer, multi-purpose, model B3E1-11 performs well in vacuum applications.

Features and Benefits

- Small and compact. Ideal for small vacuum cups, instrumentation and process control applications.
- Fully operational regardless of vacuum level. No minimum vacuum pressure required.
- Excellent as low positive pressure/vacuum pressure, selector valves. Low air pressure allows for quick vacuum level neutralizer.
- Use as vacuum diverter valve.

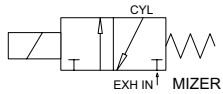

B3E1

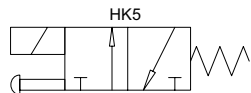

HK5

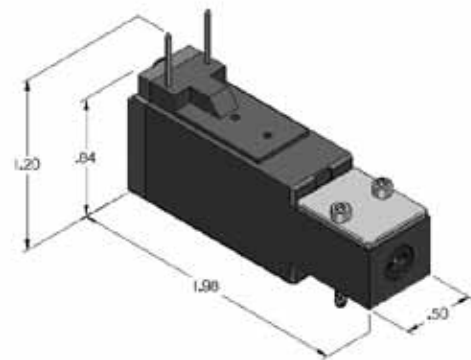

VACUUM VALVES PRESSURE RATING

MINI MIZER B3E1	28" Hg to 100 PSIG	V062E1	0 to 28" Hg
HK5	28" Hg to 100 PSIG (B and H seals) 28" Hg to 60 PSIG (E and F seals) 28" Hg to 30 PSIG (All Elastomers)	320	0 to 28" Hg
V310	0 to 28" Hg	HG010	0 to 28" Hg

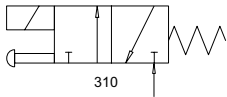

V310

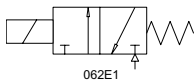
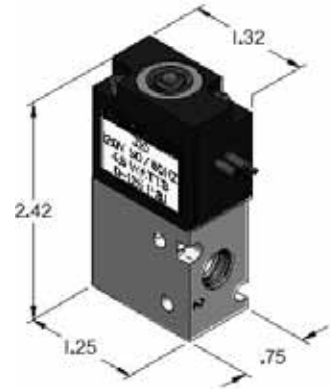

VT062E1

(V062E1 shown at right)

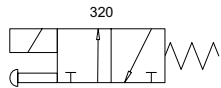

320

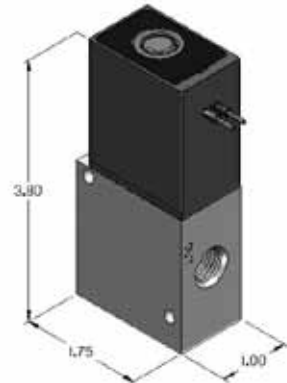

VACUUM VALVES

HOW TO OBTAIN SPECIFICATIONS FOR A PARTICULAR VALVE(S)

- ☞ Go directly to www.humphrey-products.com/dynamic/products
- ☞ Or, visit www.humphrey-products.com and select "Online Product Guide."
- Once you have followed the steps to get the valve you need, select "Download Spec Sheet." Doing this will create a personalized PDF of the valve, which you may save to your computer and print at your convenience. These spec sheets are helpful when placing your order(s).

HOW TO ORDER HUMPHREY VALVES AND ACCESSORIES

- ☞ Go directly to: www.humphrey-products.com/?q=content/find-distributor
- ☞ Or, visit www.humphrey-products.com, select "Find A Distributor," and input your information to locate a distributor nearest you.
- Or, call Customer Service at 1-800-477-8707 for the name and phone number of your local distributor.



HUMPHREY PRODUCTS ARE SOLD WORLD-WIDE THROUGH AUTHORIZED DISTRIBUTORS

Indirect-Acting Solenoid Vacuum Valves

VA250AE1(2), VV250AE1, VA500AE1(2), VV500AE1, VA590AE1(2), VV590AE1

Indirect-Acting Solenoid Humphrey Vacuum Valves feature our classic diaphragm-poppet principle. The 3-way, normally closed or normally open valves are available in 1/4, 1/2 and 3/4 PIPE port sizes. Reliable shifts whether vacuum system is clean and dry or dirty. The unbalanced, air spring return design assures vacuum tight-sealing actuated, or unactuated.

These rugged 2- or 3-way valves are available as single or double solenoid, in standard or optional brass body construction (for alternate media). Vacuum pilot models also available.

Features and Benefits

- Based on diaphragm-poppet, unbalanced principle, "the higher the vacuum, the tighter the seal."
- No sliding seals or metal-to-metal contact results in valves that are unaffected by ingest of dirt or dust, typically troublesome to competitive vacuum valves.
- Fluorocarbon seals available for high temperature resistance and/or high vacuum levels.
- Class B-rated, continuous duty coil.

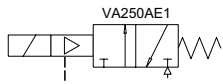

VA250AE1



VACUUM VALVES PRESSURE RATING

VA250AE1, VA250AE2	0 to 29.5" Hg	VV500AE1	20 to 29.5" Hg
VV250AE1	20 to 29.5" Hg	VA590AE1, VA590AE2	0 to 29.5" Hg
VA500AE1, VA500AE2	0 to 29.5" Hg	VV590AE1	0 to 29.5" Hg

Indirect-Acting Solenoid Vacuum Valves

VA250AE1(2), VV250AE1, VA500AE1(2), VV500AE1, VA590AE1(2), VV590AE1

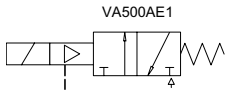

VA500AE1

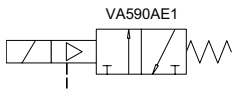
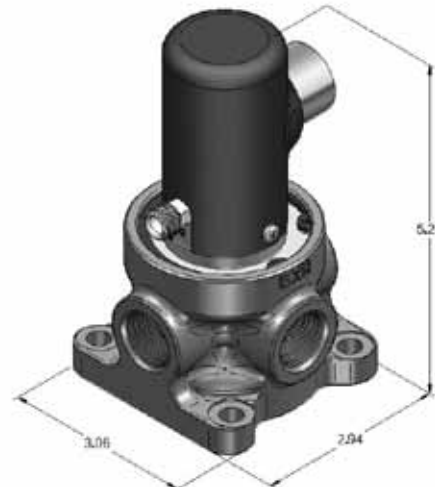

VA590AE1

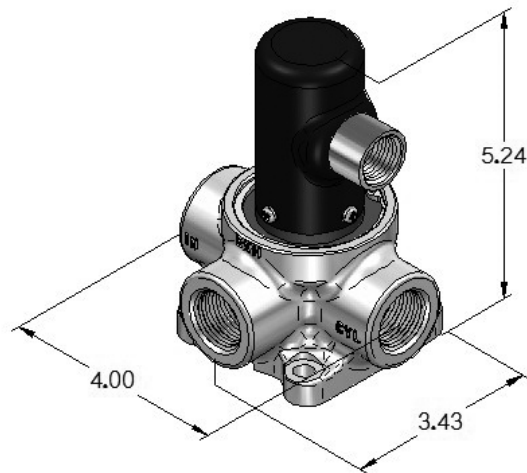

VACUUM VALVES

HOW TO OBTAIN SPECIFICATIONS FOR A PARTICULAR VALVE(S)

- Go directly to www.humphrey-products.com/dynamic/products
- Or, visit www.humphrey-products.com and select "Online Product Guide."
- Once you have followed the steps to get the valve you need, select "Download Spec Sheet." Doing this will create a personalized PDF of the valve, which you may save to your computer and print at your convenience. These spec sheets are helpful when placing your order(s).

HOW TO ORDER HUMPHREY VALVES AND ACCESSORIES

- Go directly to: www.humphrey-products.com/?q=content/find-distributor
- Or, visit www.humphrey-products.com, select "Find A Distributor," and input your information to locate a distributor nearest you.
- Or, call Customer Service at 1-800-477-8707 for the name and phone number of your local distributor.



HUMPHREY PRODUCTS ARE SOLD WORLD-WIDE THROUGH AUTHORIZED DISTRIBUTORS

Air-Pilot Vacuum Valves

VA125A, VV125A, VA250A, VV250A, VA500A, VV500A, VA590A, VV590A

Air-Pilot Humphrey Vacuum Valves feature our classic diaphragm-poppet principle. The 3-way, normally closed valves are available in 1/8, 1/4, 1/2 and 3/4 PIPE port sizes. Reliable shifts whether vacuum system is clean and dry or dirty. The unbalanced air spring return design assures vacuum tight sealing actuated, or unactuated.

These rugged 2- or 3-way, normally closed valves are available in standard or optional brass body construction (for alternate media). Vacuum pilot models also available in 1/4 PIPE and 1/2 PIPE.

Features

- Based on diaphragm-poppet unbalanced principle, "the higher the vacuum, the tighter the seal."
- No sliding seals or metal-to-metal contact results in valves that are unaffected by ingest of dirt or dust, typically troublesome to competitive vacuum valves.
- Fluorocarbon seals available for high temperature resistance and/or high vacuum levels.

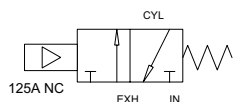

VA/VV125A

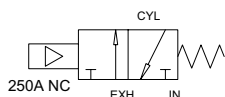
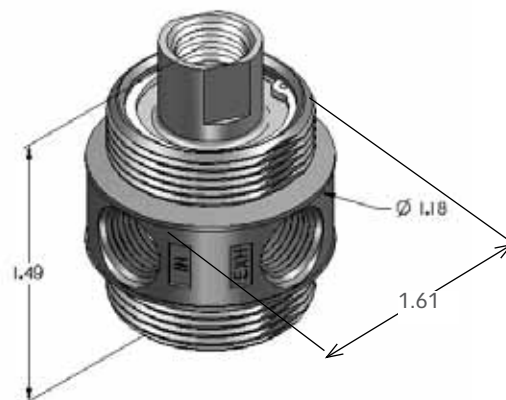

VA/VV250A

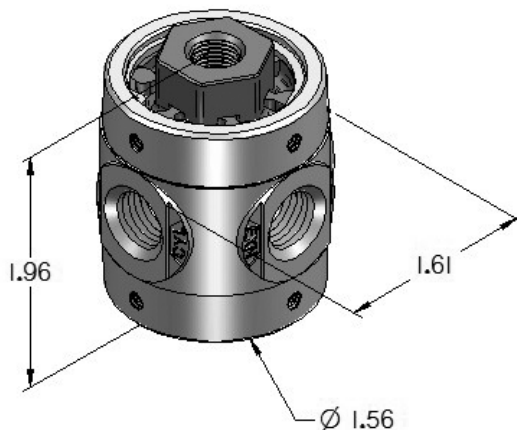

VACUUM VALVES PRESSURE RATING

VA125A	0 to 29.5" Hg	VA500A	0 to 29.5" Hg
VV125A	20 to 29.5" Hg	VV500A	20 to 29.5" Hg
VA250A	0 to 29.5" Hg	VA590A	0 to 29.5" Hg
VV250A	20 to 29.5" Hg	VV590A	20 to 29.5" Hg

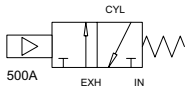

VA/VV500A

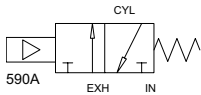
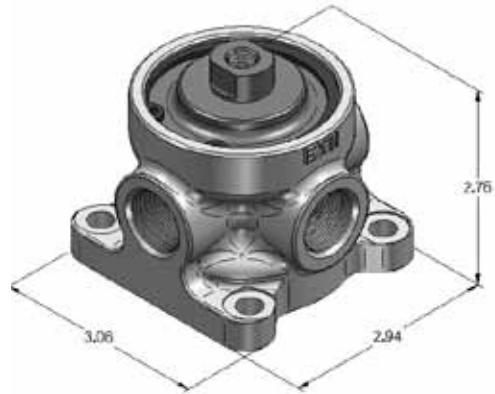

VA/VV590A

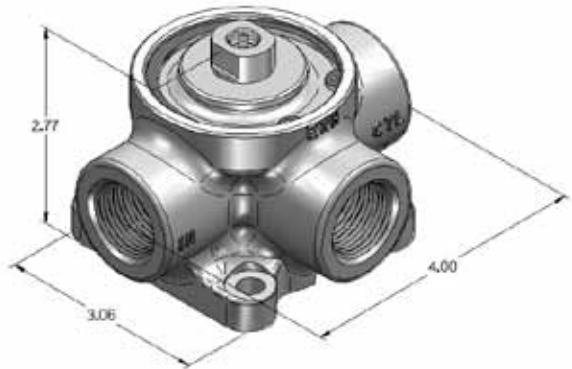

HOW TO OBTAIN SPECIFICATIONS FOR A PARTICULAR VALVE(S)

- ☞ Go directly to www.humphrey-products.com/dynamic/products
- ☞ Or, visit www.humphrey-products.com and select "Online Product Guide."
- Once you have followed the steps to get the valve you need, select "Download Spec Sheet." Doing this will create a personalized PDF of the valve, which you may save to your computer and print at your convenience. These spec sheets are helpful when placing your order(s).

HOW TO ORDER HUMPHREY VALVES AND ACCESSORIES

- ☞ Go directly to: www.humphrey-products.com/?q=content/find-distributor
- ☞ Or, visit www.humphrey-products.com, select "Find A Distributor," and input your information to locate a distributor nearest you.
- Or, call Customer Service at 1-800-477-8707 for the name and phone number of your local distributor.



HUMPHREY PRODUCTS ARE SOLD WORLD-WIDE THROUGH AUTHORIZED DISTRIBUTORS

Manual and Mechanical Vacuum Valves

V125HO, V125B, V250P, V250C, V500C

Manual and Mechanical Operated Humphrey Vacuum Valves feature our classic diaphragm-poppet principle. The 3-way, normally closed valves are available in 1/8, 1/4, and 1/2 PIPE port sizes. Reliable shifts whether vacuum system is clean and dry or dirty. The unbalanced air spring return design assures vacuum tight sealing actuated, or unactuated.

These rugged 2- or 3-way valves are available normally closed, in spring return or detent functions.

Consult factory representative or website for other models.

Features and Benefits

- Based on diaphragm-poppet, unbalanced principle, "the higher the vacuum, the tighter the seal".
- No sliding seals or metal-to-metal contact results in valves that are unaffected by ingest of dirt or dust, typically troublesome to competitive vacuum valves.
- Fluorocarbon seals available for high temperature resistance and/or high vacuum levels

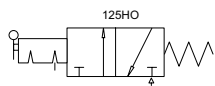

125 Manual Series



V125HO - Hold On

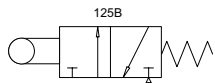
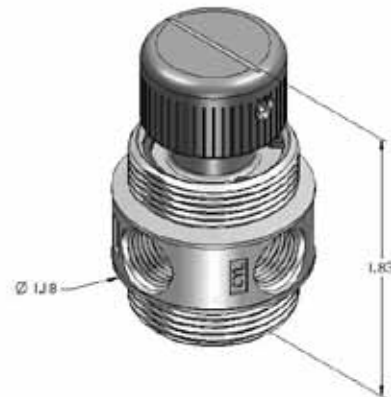

125 Mechanical Series



V125B - Ball Cam



VACUUM VALVES PRESSURE RATING

V125B, HO	0 to 29.5" Hg	V500C	0 to 29.5" Hg
V250P, C	0 to 29.5" Hg		

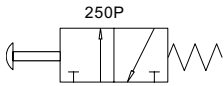

250 Manual Series



V250P – Push Button

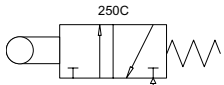
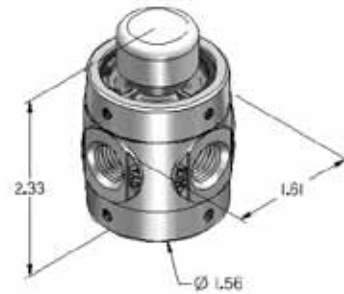

250 Mechanical Series



V250C – Cam Roller

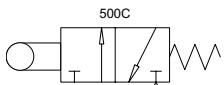
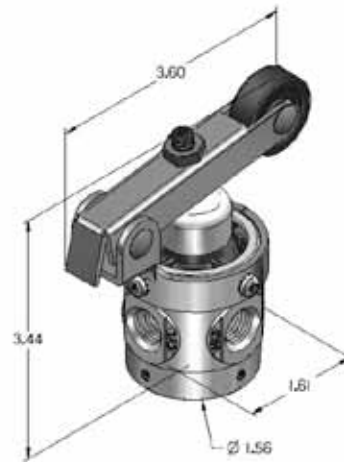

500 Mechanical Series



V500C – Cam Roller

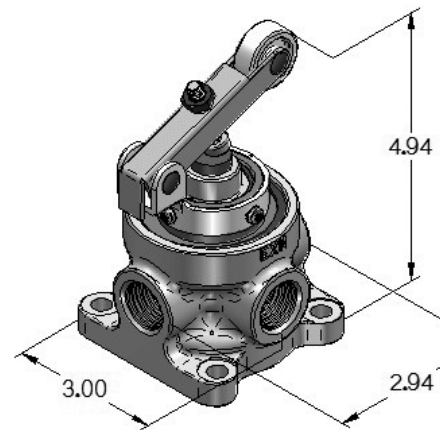

VACUUM VALVES

HOW TO OBTAIN SPECIFICATIONS FOR A PARTICULAR VALVE(S)

- ☞ Go directly to www.humphrey-products.com/dynamic/products
- ☞ Or, visit www.humphrey-products.com and select "Online Product Guide."
- Once you have followed the steps to get the valve you need, select "Download Spec Sheet." Doing this will create a personalized PDF of the valve, which you may save to your computer and print at your convenience. These spec sheets are helpful when placing your order(s).

HOW TO ORDER HUMPHREY VALVES AND ACCESSORIES

- ☞ Go directly to: www.humphrey-products.com/?q=content/find-distributor
- ☞ Or, visit www.humphrey-products.com, select "Find A Distributor," and input your information to locate a distributor nearest you.
- Or, call Customer Service at 1-800-477-8707 for the name and phone number of your local distributor.



HUMPHREY PRODUCTS ARE SOLD WORLD-WIDE THROUGH AUTHORIZED DISTRIBUTORS