

(Pneu-Trol) QUICK EXHAUST VALVES

- Instantaneous dumping of air allows use of smaller valves and piping
- Increases system efficiency and speeds

Deltrol's Quick Exhaust Valves provide fast dumping of exhaust air at the cylinder, eliminating the need for large selector valves ordinarily required to accommodate exhaust air moving back through the pneumatic system. Substantial front end savings and better operating efficiency result from the use of smaller air system components. In addition, smoother, faster cylinder operation and wider application of air-powered motions are obtained.

The Quick Exhaust Valve has been designed with smooth, over-size internal passages which afford unrestricted flow and prevent clogging due to contaminated air lines. The diaphragm is also an exclusive Deltrol design, and it assures instantaneous and complete venting of exhaust air from cylinders, air presses and other air-operated equipment.

VALVE DIMENSIONS

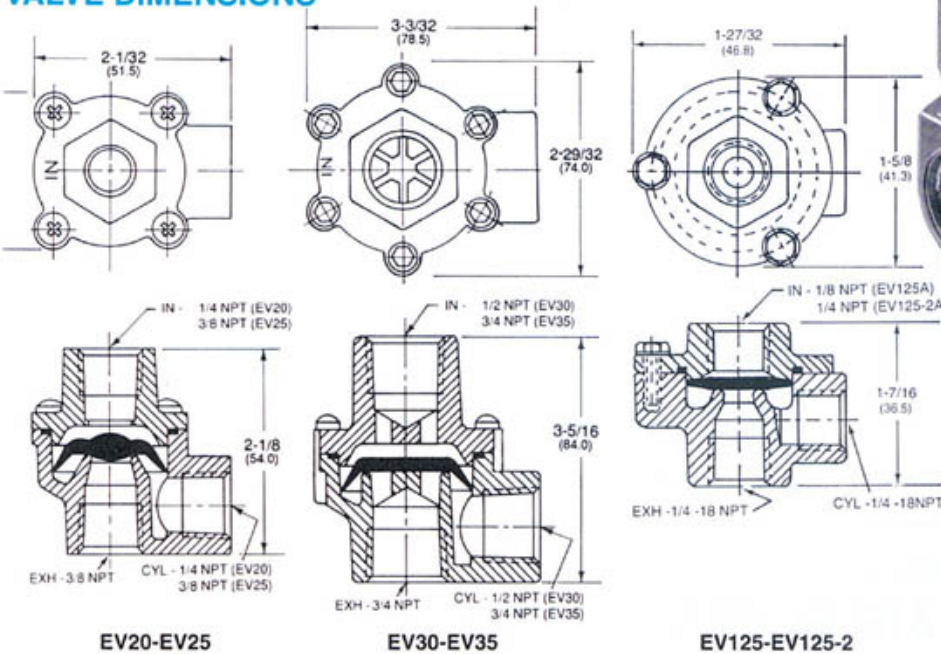

BODY - DIE CAST ALUMINUM

Model Number	Inlet Port	Inlet Cv	Cylinder Port	Exhaust Port	Exhaust Cv	Min. ΔP to Shift Diaphragm
EV125A	1/8"	.50	1/4"	1/4"	1.0	5 PSI (.3 Bar)
EV125A2	1/4"	.50	1/4"	1/4"	1.0	5 PSI (.3 Bar)
EV20A2	1/4"	1.57	1/4"	3/8"	2.33	8 PSI (.5 Bar)
EV20A2V	1/4"	1.57	1/4"	3/8"	2.33	8 PSI (.5 Bar)
EV25A2	3/8"	2.50	3/8"	3/8"	2.98	8 PSI (.5 Bar)
EV25A2V	3/8"	2.50	3/8"	3/8"	2.98	8 PSI (.5 Bar)
EV30A2	1/2"	3.48	1/2"	3/4"	5.45	3 PSI (.2 Bar)
EV30A2V	1/2"	3.48	1/2"	3/4"	5.45	3 PSI (.2 Bar)
EV35A2	3/4"	5.32	3/4"	3/4"	7.84	3 PSI (.2 Bar)
EV35A2V	3/4"	5.32	3/4"	3/4"	7.84	3 PSI (.2 Bar)

OPERATING PRESS: 20 - 125 PSI (1.4 - 8.6 BAR)
 OPERATING TEMP: STD. BUNA-N: 0 - 240 DEGREES F
 VITON*: 0 - 400 DEGREES F
 *INDICATED BY "V" AT END OF MODEL NUMBER

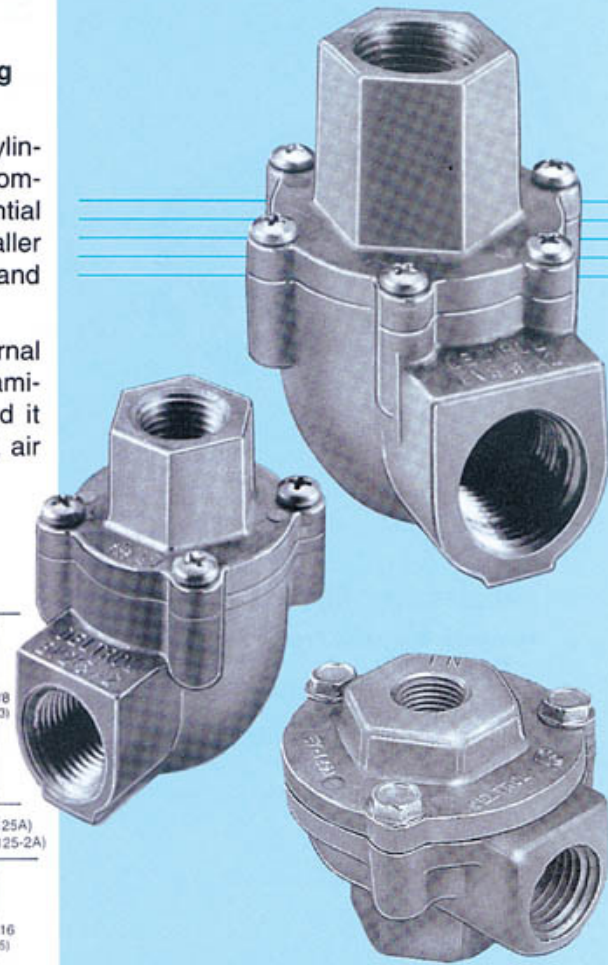
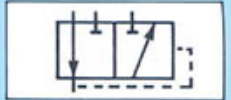

EV20A2, EV25A2, EV30A2 & EV35A2

PRINCIPLE OF OPERATION

FIGURE A

When air is introduced into the inlet port, the diaphragm is forced onto the exhaust seat. The outer lip of the diaphragm is deflected downward, away from the wall, allowing air to flow into the cylinder with a minimum of restriction. The diaphragm will remain on the exhaust seat as long as the inlet pressure is equal to or greater than the cylinder pressure.

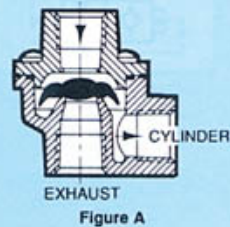

FIGURE B

When the cylinder is fully charged and air is no longer flowing from inlet to cylinder port, the outer lip of the diaphragm will assume its normal shape and will contact the outer wall. The diaphragm will remain on the exhaust seat.

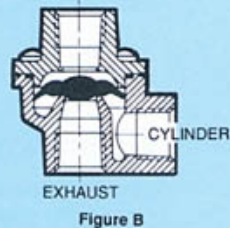

FIGURE C

When pressure at the inlet port is vented to atmosphere (thru the control valve) the air in the cylinder, which is at a pressure level higher than atmosphere will force the diaphragm upwards to the inlet port. This will shut off the inlet port and allow air in the cylinder to flow directly to atmosphere.

