

SPRAGUE PRODUCTS AIR DRIVEN HYDRAULIC PUMPS

A variety of hydraulic pumps is offered for various liquid output pressure up to 33,500 psi (2311 bar). Sprague Products pumps service water, oil and most corrosive chemicals, and are rugged, service-proven and virtually maintenance-free.

The Sprague Products positive-displacement type pump converts air inlet pressure to hydraulic output pressure. The pump uses low pressure air to act on a large area piston to produce high hydraulic pressure with a small area piston.

In operation, the pump reciprocates rapidly until the system liquid pressure nears the desired level, then slows to a stop when the liquid pressure equals or balances the air pressure. This liquid-air pressure balance is maintained indefinitely in a holding condition with minimal energy consumption and with no increase in fluid temperature or parts movement.

In contrast, a motor driven pump in a holding condition must continue to operate to maintain a pressure level. Excess liquid must be bypassed or recirculated back to the reservoir, resulting in energy loss, heat build-up, and the need for bypass components and a larger reservoir.

The Sprague Products pump is efficient in operation and simple in design. Compared to other types of hydraulic pumps, it provides cost effective and energy saving benefits for many industrial and research applications.

HYDROSTATIC TESTING APPLICATIONS

The Sprague Products air driven pump offers economical advantages for the pressure testing of hoses, pipes, valves, fittings and other hydraulic vessels and products. The time-saving and performance advantages offered by these pumps allow routine production testing to be converted from tedious hand-pump methods to automatic and precision testing methods.

PRODUCTION MACHINERY APPLICATIONS

The Sprague Products air driven pump delivers high pressure liquids required by production machinery for holding, clamping, forming, shearing, punching, etc. An application example: a hydraulic press where long holding cycles are necessary or where the work stroke is short and a high force is required. High and low volume pumps can be combined to produce a combination of high speed and high force at low cost.

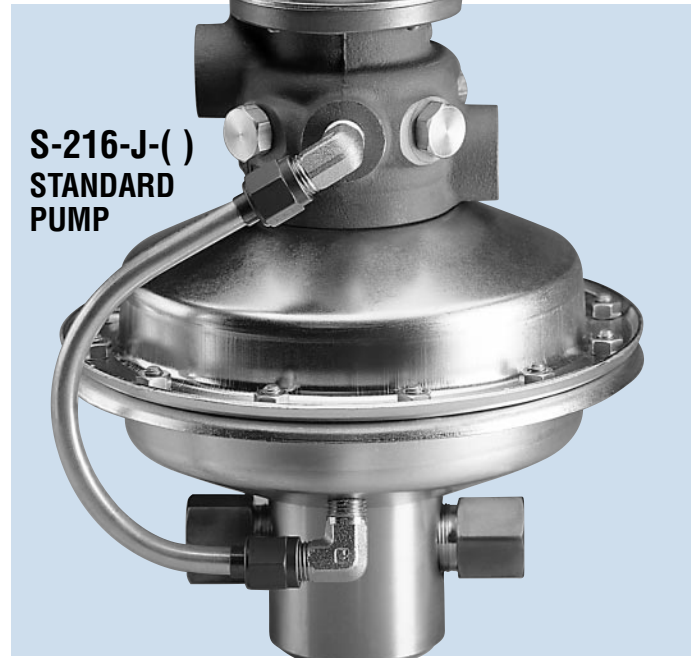

NO NEED FOR CENTRAL POWER SOURCE

Because Sprague Products air driven pumps are relatively small, they can be installed directly on individual machines or test equipment in separate locations as direct power sources. Pumps so mounted eliminate need for a central power system, long plumbing runs and excess hydraulic power capacity.

SAFE OPERATION

Unlike motor driven pumps, Sprague Products air driven pumps are non-arcing and non-sparking, and can be used safely in hazardous or confined areas.

SIMPLER MAINTENANCE

When compared to other air driven pumps, Sprague Products pumps do the same job, but with fewer parts and seals for simpler maintenance.

HOW THE S-216-J AIR DRIVEN PUMP WORKS

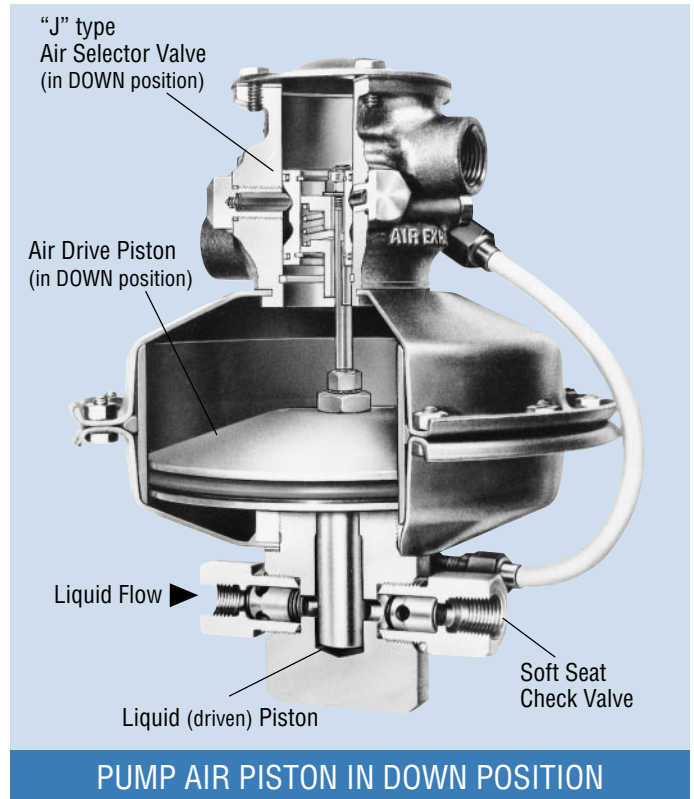
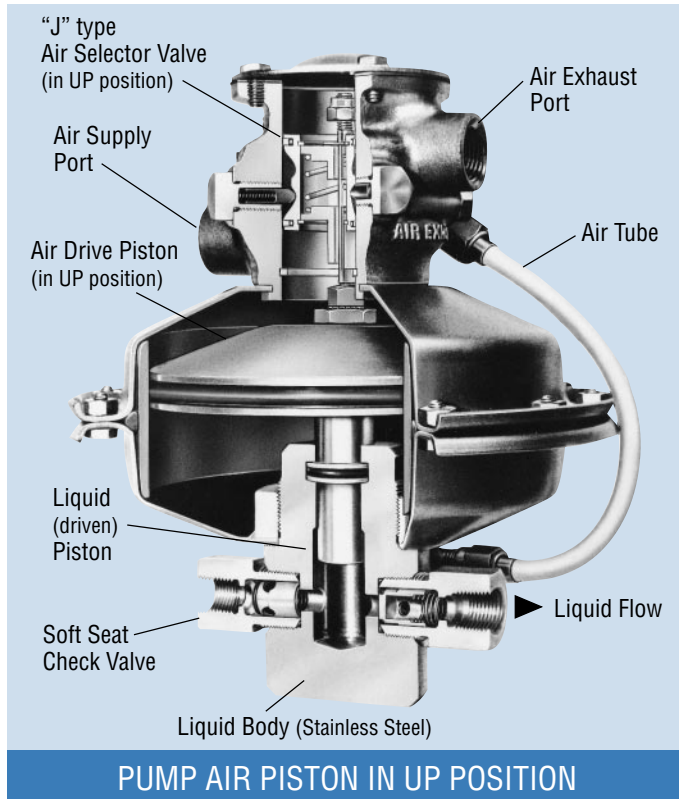

HOW THE PUMP WORKS

The Sprague Products pump develops high output pressures by applying the principle of differential areas. The pump has a large area air piston, air driven at low pressures. This air piston drives a small area liquid piston that in turn pumps liquids at high pressures.

The liquid output pressure is determined by the ratio between the area of the air drive piston, the area of the liquid driven piston and the applied operating air pressure.

The area relationship of the air piston to the liquid piston is referred to as the pump ratio. This pump ratio is indicated in the dash number which follows the pump model basic number.

Example: S-216-J-10 pump has an approximate ratio of 10 to 1 or 10 psi liquid pressure for each 1 psi of operating air pressure

In operation, an S-216-J-10 pump using 100 psi of input air pressure will produce a maximum liquid output pressure of

1000 psi; 80 psi air will produce an output pressure of 800 psi; 60 psi air . . . 600 psi output, and 40 psi air . . . 400 psi output.

By regulating the incoming air supply at the pressure regulator, the liquid output can be infinitely adjusted through the pump's pressure range.

WETTED SECTION MATERIALS

The materials used in the wetted section of the Sprague Products basic pump are compatible to most liquids to be serviced. Pump components and materials include:

| | |
|------------------------|-----------------------------------|
| Liquid Body | 303 Stainless steel |
| Liquid (driven) Piston | 416 Stainless steel chrome plated |
| Piston O-ring | Nitrile |
| Piston Back-up Ring | Teflon® or equivalent compound |
| Check Valve Body | 416 Stainless steel |
| Check Valve Poppet | 17-4ph Stainless steel |
| Check Valve Spring | 302 Stainless steel |
| Check Valve Seal | Nitrile |

ACCESSORIES

For optimum efficiency, certain accessories are recommended for use with pump. Noise can be dampened by installing muffler at pump's air exhaust port. For "J" type lubricated pumps, install an air control unit (filter, pressure regulator with air gauge and lubricator) in the supply line. For "JN" type non-lubricated pumps and boosters, install an air control unit (without lubricator) in the air supply line. These and other related accessory items are available from Sprague Products.

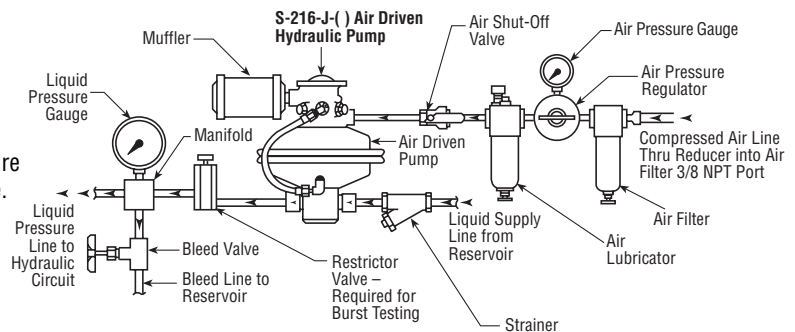

PUMP AND ACCESSORIES — TYPICAL ARRANGEMENT

TYPICAL CIRCUITS FOR SPRAGUE PRODUCTS AIR DRIVEN HYDRAULIC PUMPS

**TYPICAL SET-UP
FOR HYDRAULIC
SWAGING AND
CRIMPING PRESS**

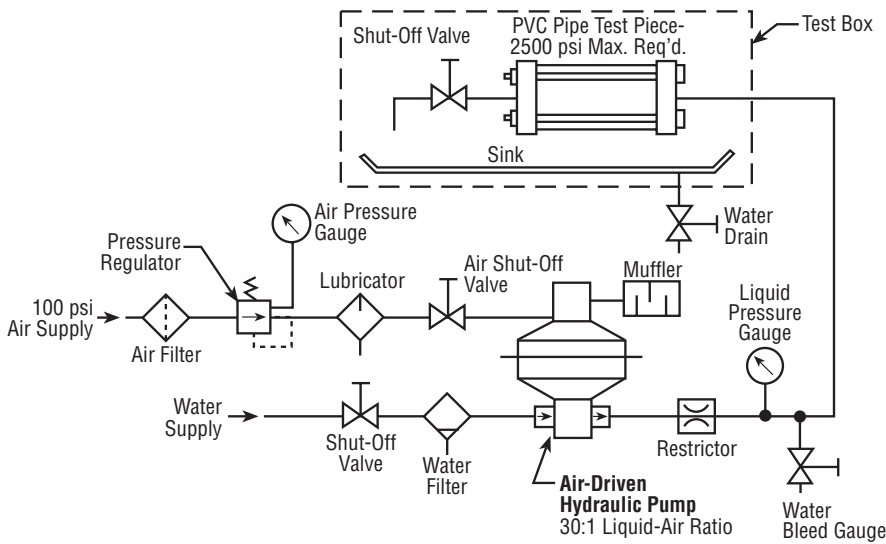
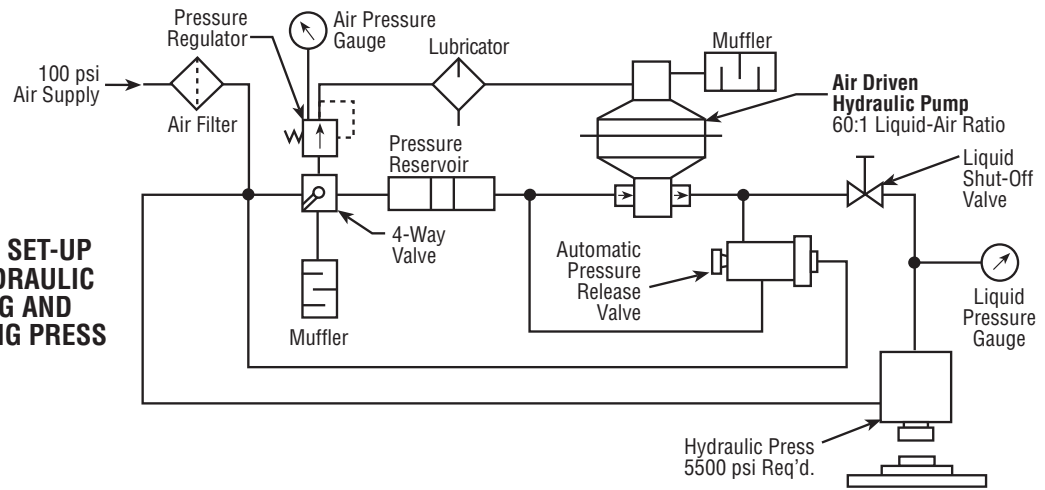

**TYPICAL PUMP SET-UP
FOR HYDROSTATIC TEST**

**HIGH-LOW PUMP SYSTEM
FOR MOLDING PRESS**

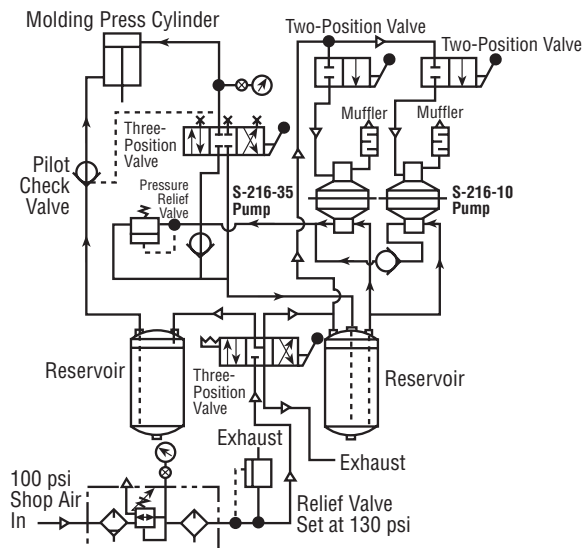

HOW TO ORDER PUMPS - MODEL PART NUMBER CODING

MODEL PART NUMBER CODING

The letter "S" preceding the basic part number refers to the manufacturer's name, Sprague Products. The letter or letters following the part number refer to the model configuration. These letters include:

- J = Standard, lubricated air
- JN = Standard, non-lubricated air
- JD = Double-acting, lubricated air
- JDN = Double-acting, non-lubricated air
- JR = Standard with reservoir, lubricated air
- JNR = Standard with reservoir, non-lubricated air
- JS = Non-contaminating, separated, lubricated air
- JSN = Non-contaminating, separated, non-lubricated air
- S = De-ionized water service, lubricated air
- SN = De-ionized water service, non-lubricated air
- GJC = S-218 pumps

The dash number following the configuration letter or letters refers to the pump or booster nominal pump ratio.

Example: S-216-J-60 = 60:1 pump nominal ratio.

HOW TO ORDER PUMPS

To order a hydraulic pump or power unit, the nominal ratio of the pump must be determined. Knowing the liquid pressure and flow requirements of the application as well as the available air pressure to operate the pump, refer to the Pump Ratio Selection Charts on page 7.

As an example, if the air supply is 100 psi and system requirement is for 1000 psi liquid discharge pressure with a 170 cubic inch per minute flow rate or capacity, the pump nominal ratio indicated on the Chart will be 60:1.

Selection of the "-60" pump means that by adjusting the driving air supply at the pressure regulator, the pump will develop any adjusted liquid output pressure ranging anywhere between 1500 psi and 6100 psi.

Use this pump ratio number as a dash number and add it to the end of the pump model number:

S-216-J-60
Standard Part Number ——— Pump Nominal Ratio (60:1)

When ordering, specify the quantity required and the liquid service. The standard S-216-J pump has a stainless steel (at no added cost) liquid body and is furnished with nitrile O-rings.

Sprague Products pumps can be furnished with other O-ring materials: Viton®, Neoprene, EPR and other compounds. For questions regarding liquid/seal compatibility, contact Sprague Products for recommendations for the seal compound suited to the application.

Also, when ordering, specify operating temperature range (if known) and any other special conditions applicable.

The "GJC" letter combination is part of the S-218-GJC-() pump basic part number. The dash number, -45 or -65, refers to the pump nominal ratio. **Example:**

S-218-GJC-45
Standard Part Number ——— Pump Nominal Ratio (45:1)

PUMPS FOR FREON® SERVICE

Sprague Products pumps can be ordered with minor modifications from the factory to service most liquid Freon refrigerants, solvents and fire extinguishing agents. Suitable seals, compatible to these liquids, are installed in the liquid body and in the inlet and outlet check valves. The pump may require other minor modifications.

When ordering a pump for this special service, specify the exact Dupont designation to be used (i.e., 12, 22, etc.) or the specific designations of other liquids.

Viton is a registered trademark of DuPont Dow Elastomers
Freon is a registered trademark of the DuPont Company

PUMP RATIO SELECTION CHART

for the following pump models: S-216-J, S-216-JN, S-216-JS, and S-216-JSN

| 100 psi Driving Air Supply | | | | | | | | | | | | | | | | | | |
|--|-------------------------|---------------------------------|---------------------------------|-----|-----|-----|------|------|------|------|------|------|------|------|-----|-----|-----|-----|
| NOM. RATIO | MAXIMUM OUTPUT PRESSURE | DISPLACEMENT PER STROKE CU. IN. | LIQUID DISCHARGE PRESSURE - psi | | | | | | | | | | | | | | | |
| | | | 0 | 250 | 500 | 750 | 1000 | 1500 | 2000 | 2500 | 3000 | 4000 | 5000 | 7500 | 10M | 15M | 20M | 30M |
| Capacities - Cubic Inches Per Minute Approximate | | | | | | | | | | | | | | | | | | |
| 10:1 | 1000 | 3.26 | 485 | 560 | 484 | 324 | | | | | | | | | | | | |
| 20:1 | 1850 | 1.75 | 485 | 440 | 400 | 364 | 320 | 212 | | | | | | | | | | |
| 30:1 | 3100 | 1.04 | 332 | 284 | 268 | 256 | 236 | 208 | 174 | 125 | 42 | | | | | | | |
| 35:1 | 4600 | .708 | 297 | 238 | 225 | 214 | 200 | 185 | 164 | 142 | 122 | 69 | | | | | | |
| 60:1 | 6100 | .527 | 213 | 190 | 186 | 177 | 170 | 154 | 140 | 123 | 107 | 86 | 60 | | | | | |
| 100:1 | 8800 | .366 | 172 | 138 | 132 | 128 | 126 | 118 | 111 | 106 | 98 | 88 | 76 | 53 | | | | |
| 125:1 | 12500 | .266 | 130 | 122 | 115 | 112 | 110 | 104 | 99 | 94 | 88 | 85 | 75 | 57 | 40 | | | |
| 150:1 | 16000 | .205 | 78 | 77 | 76 | 74 | 72 | 68 | 66 | 63 | 60 | 56 | 53 | 44 | 38 | 20 | | |
| 200:1 | 23750 | .132 | 53 | 52 | 50 | 49 | 48 | 47 | 46 | 45 | 43 | 41 | 38 | 34 | 30 | 20 | 9 | |
| 300:1 | 33500 | .092 | 37 | 36 | 35 | 34 | 33 | 33 | 32 | 31 | 30 | 30 | 29 | 26 | 23 | 18 | 14 | 6 |

NOMINAL PERFORMANCE (BASED ON OPERATING AIR SUPPLY OF 50 STANDARD CUBIC FEET PER MINUTE @ 100 psi)

| 6.9 bar Driving Air Supply METRIC SCALE (equivalent to 100 psi Driving Air Supply) | | | | | | | | | | | | | | | | | | |
|--|---------------------------|---------------------------------|-----|-----|-----|-----|-----|-----|-----|-----|-----|-----|-----|-----|------|------|------|--|
| NOM. RATIO | V MAXIMUM OUTPUT PRESSURE | LIQUID DISCHARGE PRESSURE - bar | | | | | | | | | | | | | | | | |
| | | 0 | 17 | 34 | 48 | 69 | 103 | 138 | 172 | 207 | 276 | 345 | 517 | 689 | 1034 | 1379 | 2068 | |
| Capacities - Liters Per Minute Approximate | | | | | | | | | | | | | | | | | | |
| 10:1 | 69 | 7.9 | 9.1 | 7.5 | 5.3 | | | | | | | | | | | | | |
| 20:1 | 128 | 7.9 | 7.2 | 6.6 | 6 | 5.2 | 3.5 | | | | | | | | | | | |
| 30:1 | 214 | 5.4 | 4.7 | 4.4 | 4.2 | 3.9 | 3.4 | 2.9 | 2 | .7 | | | | | | | | |
| 35:1 | 317 | 4.9 | 3.9 | 3.7 | 3.5 | 3.3 | 3 | 2.7 | 2.3 | 2 | 1.1 | | | | | | | |
| 60:1 | 420 | 3.5 | 3.1 | 3 | 2.9 | 2.8 | 2.5 | 2.3 | 2 | 1.8 | 1.4 | 1 | | | | | | |
| 100:1 | 607 | 2.8 | 2.3 | 2.2 | 2.1 | 2.0 | 1.9 | 1.8 | 1.7 | 1.6 | 1.4 | 1.2 | .9 | | | | | |
| 125:1 | 862 | 2.1 | 2.0 | 1.7 | 1.8 | 1.8 | 1.7 | 1.6 | 1.5 | 1.4 | 1.3 | 1.2 | .9 | .7 | | | | |
| 150:1 | 1103 | 1.3 | 1.3 | 1.2 | 1.2 | 1.2 | 1.1 | 1.1 | 1 | 1 | .9 | .9 | .7 | .6 | .3 | | | |
| 200:1 | 1637 | .9 | .9 | .8 | .8 | .8 | .8 | .8 | .7 | .7 | .7 | .6 | .6 | .5 | .3 | .15 | | |
| 300:1 | 2310 | .6 | .6 | .6 | .6 | .5 | .5 | .5 | .5 | .5 | .5 | .5 | .4 | .4 | .3 | .2 | .1 | |

NOMINAL PERFORMANCE (BASED ON 1.4 STD. CU. METERS OF DRIVING AIR AT 6.9 bar)

High Pressure Connections

All pumps that are capable of pressures exceeding 10,000 psi are equipped with 9/16-18 NBS outlet check valves that accept coned and threaded tube fittings.

NOTE: See page 30 for additional H.P. connections.

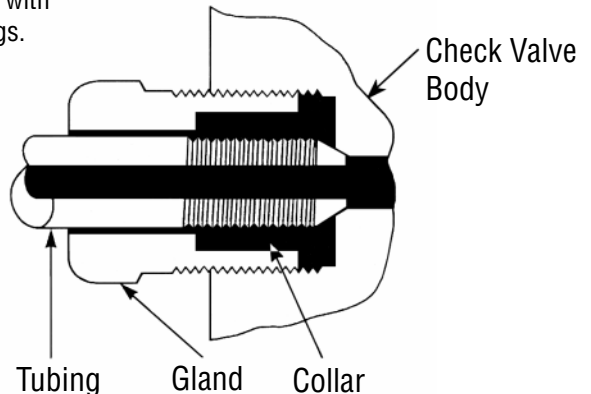
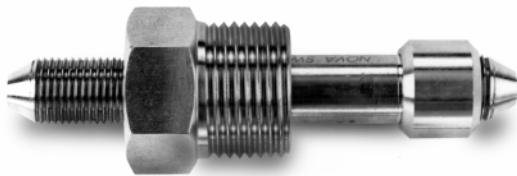

THE S-216-J STANDARD HYDRAULIC PUMP

and S-216-JN Non-Lubricated Pump



S-216-J-()

S-216-J-() STANDARD PUMP, LUBRICATED

This general use, air driven pump produces medium to high liquid pressures and services oil, water and compatible chemicals.

The Model S-216-J standard pump is offered in ten ratios (area of large air piston to area of small liquid piston) ranging from the 10:1 ratio pump which develops up to 1000 psi (69 bar) to the 300:1 ratio which develops up to 33,500 psi (2311 bar). By regulating the driving air pressure, the pump's liquid output can be adjusted through its pressure range.

The pump's wetted section components are stainless steel, compatible with most non-abrasive liquids.

Being air driven, the pump is safe for use in hazardous areas.

The S-216-J standard pump requires lubricated driving air to lubricate the pump's dynamic air seals and other internal parts within the air portion of the pump.

When determining the appropriate pump nominal ratio to order, refer to page 6, How To Order Pumps and Pump Ratio Selection Chart.

Example: S-216-J-60
 Pump Model Number ——— Pump Nominal Ratio

S-216-J

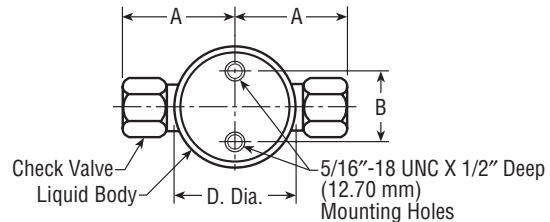
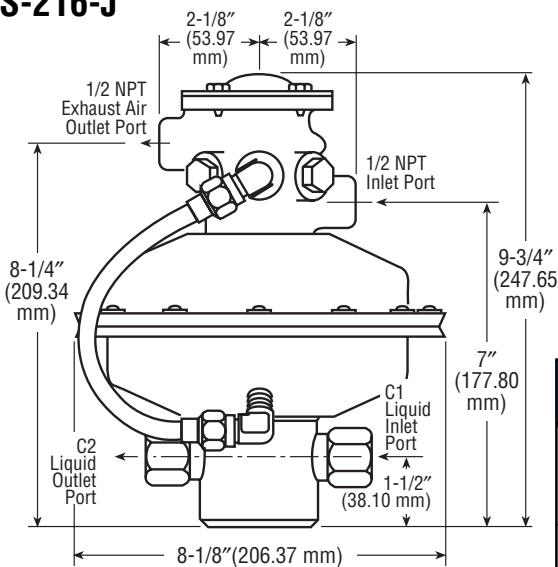

| Nominal Ratio | A | | B | | C1 Inlet | C2 Outlet | D/Dia. | |
|---------------|---------|-------|--------|-------|----------|-------------|--------|-------|
| | Inch | mm | Inch | mm | | | Inch | mm |
| 10:1 | 2-29/32 | 73.82 | 2-7/16 | 61.90 | 3/8 NPT | 3/8 NPT | 3-1/2 | 88.86 |
| 20:1 | 2-29/32 | 73.82 | 2-7/16 | 61.90 | 3/8 NPT | 3/8 NPT | 3-1/4 | 82.51 |
| 30:1 | 2-29/32 | 73.82 | 2-7/16 | 61.90 | 3/8 NPT | 3/8 NPT | 3-1/4 | 82.51 |
| 35:1 | 2-1/4 | 57.15 | 1-1/2 | 38.10 | 3/8 NPT | 3/8 NPT | 2-1/2 | 63.47 |
| 60:1 | 2-1/4 | 57.15 | 1-1/2 | 38.10 | 3/8 NPT | 3/8 NPT | 2-1/2 | 63.47 |
| 100:1 | 2-1/4 | 57.15 | 1-1/2 | 38.10 | 3/8 NPT | 3/8 NPT | 2-1/2 | 63.47 |
| 125:1 | 2-1/4 | 57.15 | 1-1/2 | 38.10 | 1/4 NPT | 9/16-18 NBS | 2-1/2 | 63.47 |
| 150:1 | 2-1/4 | 57.15 | 1-1/2 | 38.10 | 1/4 NPT | 9/16-18 NBS | 2-1/2 | 63.47 |
| 200:1 | 2-1/4 | 57.15 | 1-1/2 | 38.10 | 1/4 NPT | 9/16-18 NBS | 2-1/2 | 63.47 |
| 300:1 | 2-1/4 | 57.15 | 1-1/2 | 38.10 | 1/4 NPT | 9/16-18 NBS | 2-1/2 | 63.47 |

| Pump Model No. | Reference Number | Maximum Output - See Note | | Driving Air | Port Threads Liquid | | Actual Weight | | Shipping Weight | |
|-------------------------------|----------------------------|---------------------------|------|-------------|---------------------|-------------|---------------|------|-----------------|------|
| | | psi | bar | | Inlet | Outlet | lbs.-oz. | kg | lbs.-oz. | kg |
| S-216-J-10 S-216-JN-10 | 79293-11 89842-11 | 1000 | 69 | 1/2 NPT | 3/8 NPT | 3/8 NPT | 16-4 | 7.4 | 19 | 8.6 |
| S-216-JR-10 S-216-JNR-10 | 91612-11 91613-11 | 1000 | 69 | 1/2 NPT | 3/8 NPT | 3/8 NPT | 24-4 | 11.0 | 27-4 | 12. |
| S-216-J-20 S-216-JN-20 | 77894-11 89842-21 | 1860 | 128 | 1/2 NPT | 3/8 NPT | 3/8 NPT | 14-8 | 6.6 | 17 | 7.7 |
| S-216-JR-20 S-216-JNR-20 | 91612-21 91613-21 | 1860 | 128 | 1/2 NPT | 3/8 NPT | 3/8 NPT | 22-8 | 10.2 | 25-8 | 11.6 |
| S-216-J-30 S-216-JN-30 | 77894-21 89842-31 | 3100 | 214 | 1/2 NPT | 3/8 NPT | 3/8 NPT | 14-8 | 6.6 | 17 | 7.7 |
| S-216-JR-30 S-216-JNR-30 | 91612-31 91613-31 | 3100 | 214 | 1/2 NPT | 3/8 NPT | 3/8 NPT | 22-8 | 10.2 | 25-8 | 11.6 |
| S-216-J-35 S-216-JN-35 | 77895-81 89842-41 | 4600 | 317 | 1/2 NPT | 3/8 NPT | 3/8 NPT | 12-8 | 5.7 | 15 | 6.8 |
| S-216-JR-35 S-216-JNR-35 | 91612-41 91613-41 | 4600 | 317 | 1/2 NPT | 3/8 NPT | 3/8 NPT | 20-8 | 9.3 | 23-8 | 10.7 |
| S-216-J-60 S-216-JN-60 | 77895-11 89842-51 | 6100 | 420 | 1/2 NPT | 3/8 NPT | 3/8 NPT | 12-8 | 5.7 | 15 | 6.8 |
| S-216-JR-60 S-216-JNR-60 | 91612-51 91613-51 | 6100 | 420 | 1/2 NPT | 3/8 NPT | 3/8 NPT | 20-8 | 9.3 | 23-8 | 10.7 |
| S-216-J-100 S-216-JN-100 | 77895-21 89842-61 | 8800 | 607 | 1/2 NPT | 3/8 NPT | 3/8 NPT | 12-8 | 5.7 | 15 | 6.8 |
| S-216-JR-100 S-216-JNR-100 | 91612-61 91613-61 | 8800 | 607 | 1/2 NPT | 3/8 NPT | 3/8 NPT | 20-8 | 9.3 | 23-8 | 10.7 |
| S-216-J-125 S-216-JN-125 | 77895-61001 89842-01001 | 12500 | 862 | 1/2 NPT | 1/4 NPT | 9/16-18 NBS | 12-8 | 5.7 | 15 | 6.8 |
| S-216-JR-125 S-216-JNR-125 | 90612-01001 91613-01001 | 12500 | 862 | 1/2 NPT | 1/4 NPT | 9/16-18 NBS | 12-8 | 5.7 | 15 | 6.8 |
| S-216-J-150 S-216-JN-150 | 77895-31001 89842-71001 | 16,000 | 1103 | 1/2 NPT | 1/4 NPT | 9/16-18 NBS | 12-8 | 5.7 | 15 | 6.8 |
| S-216-JR-150 S-216-JNR-150 | 91612-71001 91613-71001 | 16,000 | 1103 | 1/2 NPT | 1/4 NPT | 9/16-18 NBS | 20-8 | 9.3 | 23-8 | 10.7 |
| S-216-J-200 S-216-JN-200 | 77985-41001 89842-81001 | 23,750 | 1637 | 1/2 NPT | 1/4 NPT | 9/16-18 NBS | 12-8 | 5.7 | 15 | 6.8 |
| S-216-JR-200 S-216-JNR-200 | 91612-81001 91613-81001 | 23,750 | 1637 | 1/2 NPT | 1/4 NPT | 9/16-18 NBS | 20-8 | 9.3 | 23-8 | 10.7 |
| S-216-J-300 S-216-JN-300 | 77985-51001 89842-91001 | 33,500 | 2310 | 1/2 NPT | 1/4 NPT | 9/16-18 NBS | 12-8 | 5.7 | 15 | 6.8 |
| S-216-JR-300 S-216-JNR-300 | 91612-91001 91613-91001 | 33,500 | 2310 | 1/2 NPT | 1/4 NPT | 9/16-18 NBS | 20-8 | 9.3 | 23-8 | 10.7 |

NOTE: -125 ratios also offered with 3/8 NPT liquid connections for working pressures under 10,000 psi.

NOTE: Pump maximum output pressure is based on 100 psi (6.9 bar) driving air pressure.

S-216-JN-() STANDARD PUMP, NON-LUBRICATED

Mechanically the same as the S-216-J standard pump, this S-216-JN-() pump is suitable for use in cleanrooms or laboratories. The pump uses normal shop compressed air without lubrication to actuate the pump. Its dynamic air seals are self-lubricating. The pump's exhaust air is identical to the driving air supply, so no additional contaminants are added to the exhaust air. Order in the same manner as the S-216-J and add an "N" to model number.

Example: S-216-JN-60

Pump Model Number ——— Pump Nominal Ratio

S-216-J-()HO HIGH OUTPUT PUMP, LUBRICATED

S-216-JN-()HO HIGH OUTPUT PUMP, NON-LUBRICATED

Mechanically the same as the S-216-J-() or S-216-JN-() pumps, the S-216-()-()HO pumps utilize larger air passageways

to dramatically increase pump speeds. Flows of up to double the standard published flow rates are available with the high output pumps.

S-216-JR-() STANDARD PUMP/RESERVOIR, LUBRICATED

This pump assembly combines the S-216-J standard pump (lubricated air type) with a one-gallon (3.8 liters) steel reservoir. Readily adaptable to portable power pack use or suitable for stationary use to provide hydraulic power for production machinery or for hydrostatic testing. Available in ten pump ratios.

S-216-JNR-() PUMP/RESERVOIR, NON-LUBRICATED

Same as S-216-JR-() assembly except that the S-216-JN-() standard pump (non-lubricated air type) is used. No additional contaminants are exhausted from the pump. Available in ten pump ratios.

HYDRAULIC POWER UNITS

equipped with reservoirs

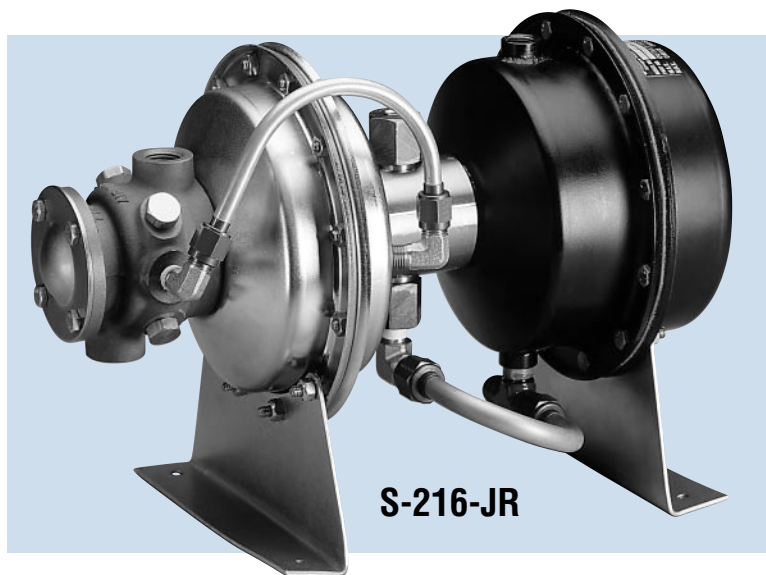

S-216-JR-() STANDARD PUMP/RESERVOIR. LUBRICATED (FOR OIL SERVICE ONLY)

This pump assembly combines the S-216-J standard pump (lubricated air type) with a one-gallon (3.8 liters) steel reservoir. Readily adaptable to portable power pack use. Also suitable for stationary use to provide hydraulic power for production machinery or for hydrostatic testing. This unit is not available in 150:1, 200:1 or 300:1 ratios.

S-216-JNR-() PUMP/RESERVOIR. NON-LUBRICATED (FOR OIL SERVICE ONLY)

Same as S-216-JR-() assembly except that the S-216-JN () standard pump (non-lubricated air type) is used. No additional contaminants are exhausted from the pump.

S-216-JR NOMINAL DIMENSIONS AND CLEARANCES

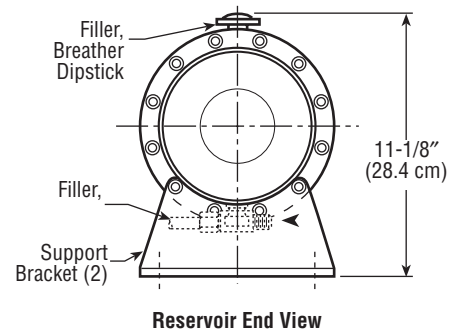
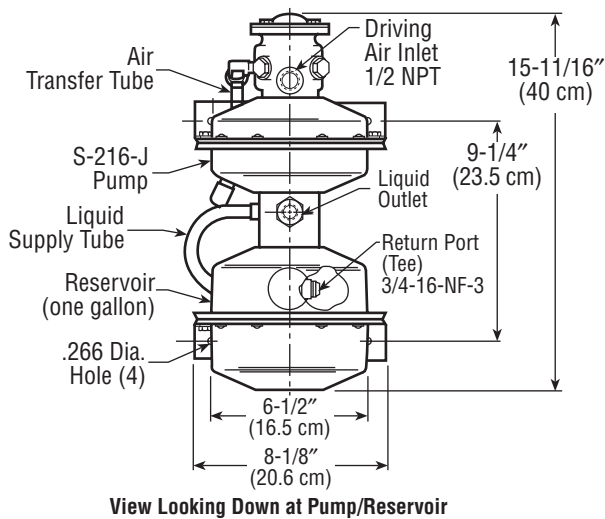

S-440-JR-() COMPACT POWER UNIT WITH RESERVOIR (FOR OIL SERVICE ONLY)

This compact, lightweight, hydraulic power unit with reservoir weighs less than 33 pounds and is ideal for pressurizing small hydraulic clamps, cylinders and hydrostatic testing.

The unit comes complete with the S-216-J-() basic pump (available in six popular pressure ratios), air filter, pressure regulator and lubricator (FRL), air shut-off valve, muffler, manifold, liquid bleed valve, air pressure gauge, liquid pressure gauge and one gallon reservoir with dipstick. This unit is not available in 150:1, 200:1 or 300:1 ratios.

S-440-JNR-() COMPACT POWER UNIT WITH RESERVOIR, NON-LUBRICATED

This power unit with reservoir is the same as the S-440-JR-() except that it utilizes the S-216-JN-() non-lubricated pump and the lubricator is removed from the FRL.