

RD-1 Rotary Drive

0-180° Fully Adjustable



Features

- Angle of rotation adjusted with built in stop screws with fine threads
- Stop screws are compatible with sensing switches
- Designed for production rates and long life
- Two sealed ball bearings at top and bottom of drive shaft
- Tapped holes and offset dowel pin area in shaft and driving flange allows higher torque transmittal and accuracy
- Bearings are positioned very close to the drive gear for rigidity, precision, wear resistance and accuracy.
- Shaft is stopped with an adjustable hard stopscrew against a hardened pin, eliminating backlash

Dimensions

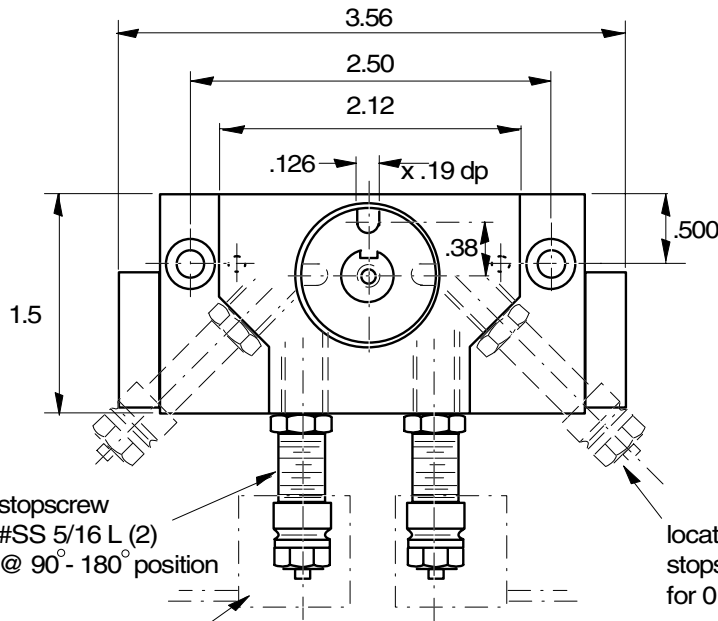

stopscrew
#SS 5/16 L (2)
@ 90° - 180° position

sensing switches
(optional)

location of
stopscrews
for 0 - 90°

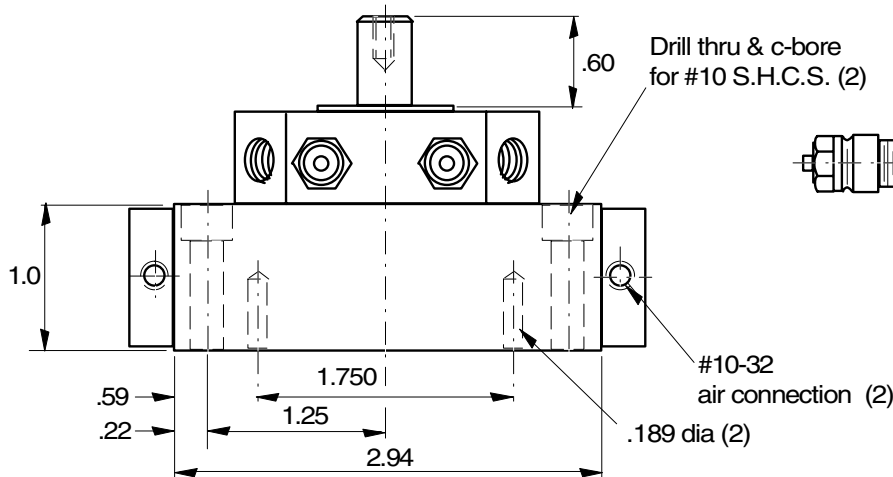

Drill thru & c-bore
for #10 S.H.C.S. (2)

#10-32
air connection (2)
.189 dia (2)

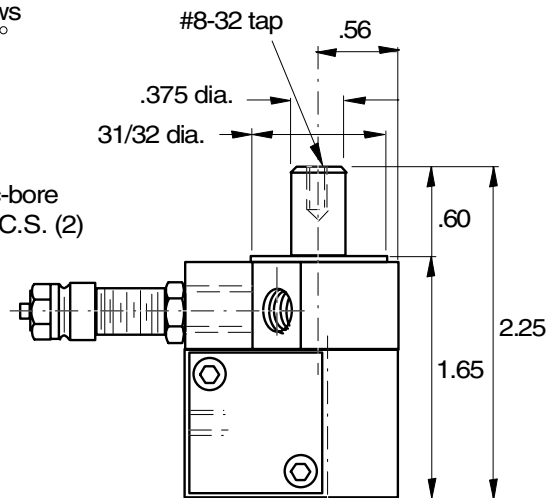

**Note: shown in
mid-position**

Technical Data

Bore	= 0.5"
Repeat accuracy	= +/-0.0005"
Life expectancy	= 5-6 million cycles
Compressed air	= 60 to 100 psi
Angle of rotation	= 0 to 180 degrees
Weight	= 1 lbs
Air connection	= 10-32
Max radial bearing load	= 4 lbs
Max axial bearing load	= 6 lbs

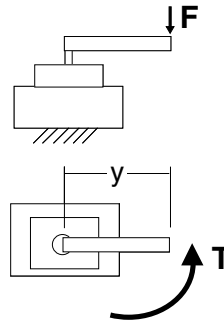

Pressure	Piston Area (in ²)	Max Torque (in-lbs)
60	.196	2.9
70	.196	3.4
80	.196	3.9
90	.196	4.4
100	.196	4.9

The diagrams above depict the load (F) on an arm of length = y. Also shown is the torque of the RD-1 which is given in the chart:

Load vs. Distance for Different Cycle Times (@80psi)
 Load (for any P) = Graph value *(P/80)

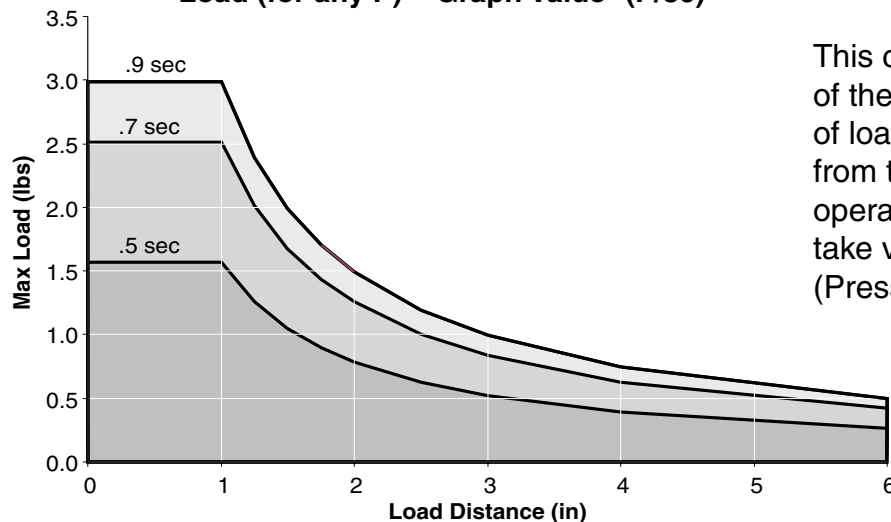

This chart shows how the cycle time of the RD-1 is affected by the amount of load and distance the load is from the shaft, for 180° rotation. For operating pressures other than 80, take value from graph and multiply by (Pressure in psi/80).



Options

Sensing switches are available as an option. They are mounted to the stopscrews as seen in the photo to the right. For specifications on sensing please see page 143.

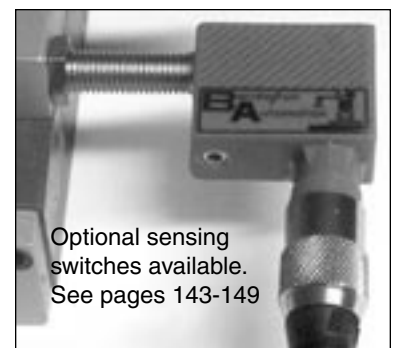

RD-2 Rotary Drive

0-180° Fully Adjustable

Features

- Angle of rotation adjusted with built in stop screws with fine threads
- Stop screws are compatible with sensing switches
- End stops deceleration with available cushions or shocks
- Designed for production rates and long life
- Two sealed ball bearings at top and bottom of drive shaft
- Tapped holes and offset dowel pin area in shaft and driving flange allows higher torque transmittal and accuracy
- Bearings are positioned very close to the drive



gear for rigidity, precision, wear resistance and accuracy.

- Shaft is stopped with an adjustable hard stopscrew against a hardened pin, eliminating backlash

Dimensions

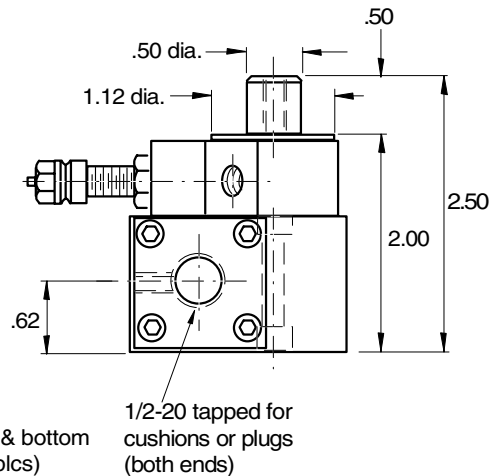
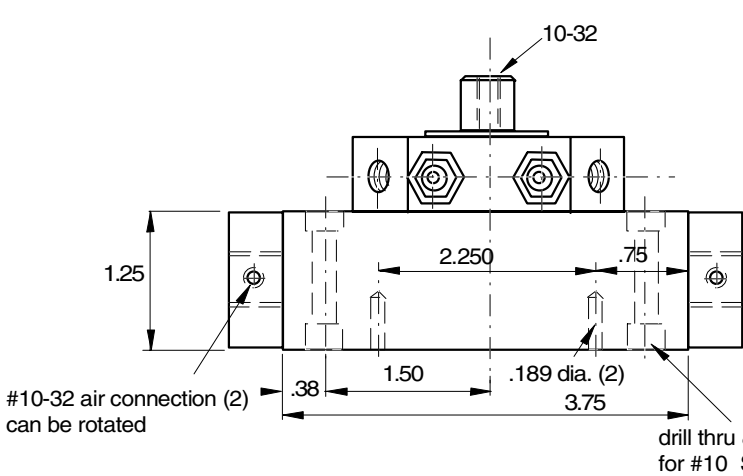
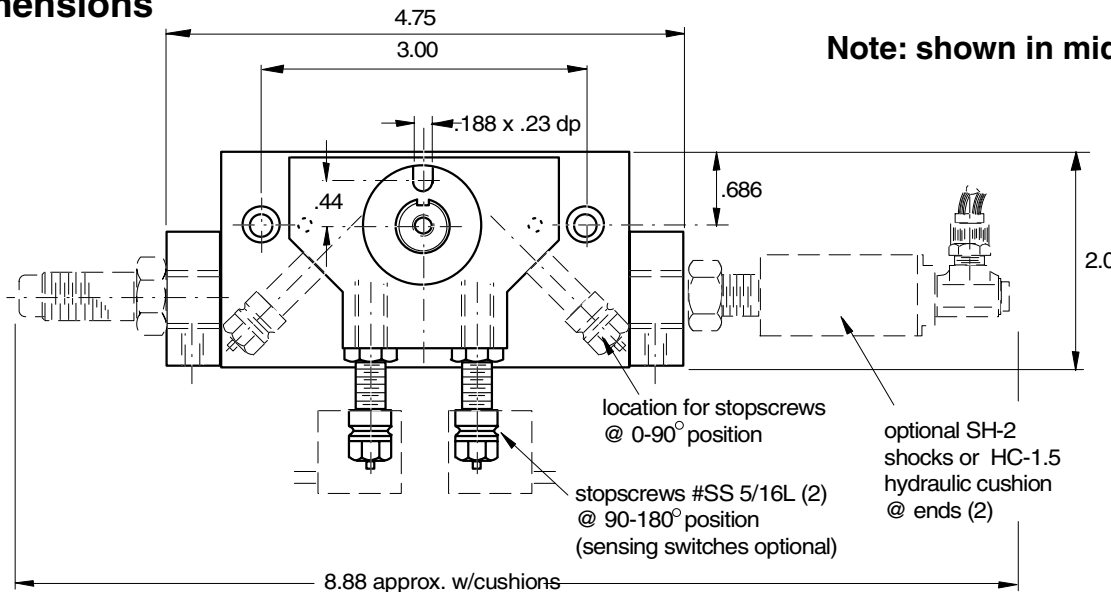

M

RD-2 Rotary Drive

Technical Data

Bore	= 0.75"
Repeat accuracy	= +/-0.0005"
Life expectancy	= 5-6 million cycles
Compressed air	= 60 to 100 psi
Angle of rotation	= 0 to 180 degrees
Weight	= 2 lbs
Air connection	= 10-32
Max radial bearing load	= 8 lbs
Max axial bearing load	= 12 lbs

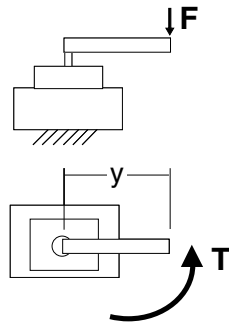

Pressure	Piston Area (in ²)	Max Torque (in-lbs)
60	.442	9.4
70	.442	11.0
80	.442	12.6
90	.442	14.2
100	.442	15.7

The diagrams above depict the load (F) on an arm of length = y. Also shown is the torque of the RD-2 which is given in the chart:

Load vs. Distance for Different Cycle Times (@80psi)
Load (for any P) = Graph value *(P/80)

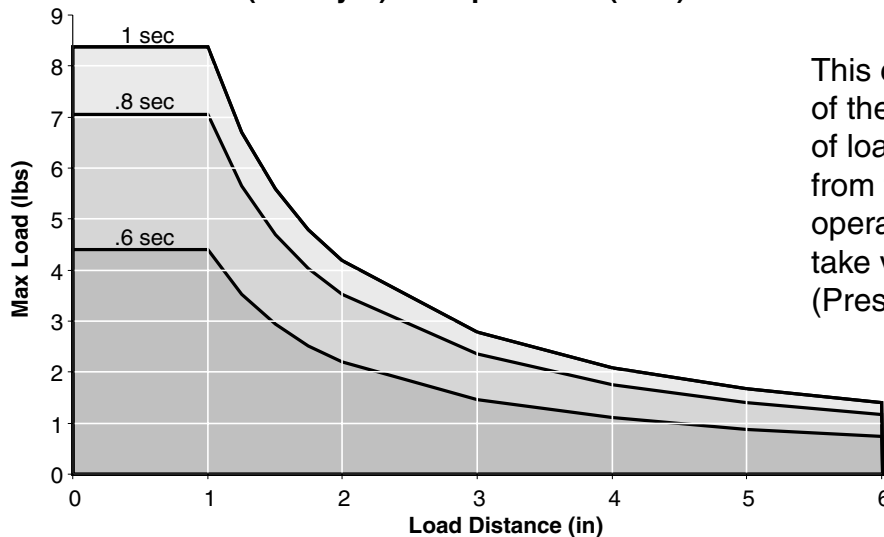

This chart shows how the cycle time of the RD-2 is affected by the amount of load and distance the load is from the shaft, for 180° rotation. For operating pressures other than 80, take value from graph and multiply by (Pressure in psi/80).



Options

Sensing switches are available as an option. They are mounted to the stopscrews as seen in the photo to the right. For specifications on sensing please see page 143. Shocks or cushions are also available.

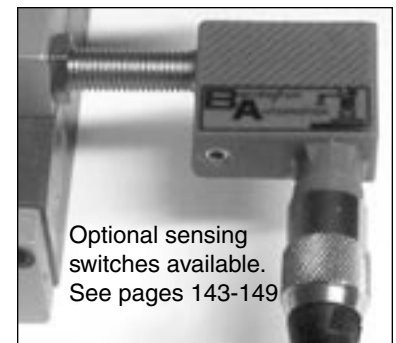

RD-3 Rotary Drive



0-180° Fully Adjustable

Features

- Angle of rotation adjusted with built in stop screws with fine threads
- Stop screws are compatible with sensing switches
- End stops deceleration with available cushions
- Designed for production rates and long life
- Piston has hardened pin to strike for longevity
- Two sealed ball bearings at top and bottom of drive shaft
- Tapped holes and offset dowel pin area in shaft and driving flange allows higher torque transmittal and accuracy
- Bearings are positioned very close to the drive



gear for rigidity, precision, wear resistance and accuracy.

- Shaft is stopped with an adjustable hard stopscrew against a hardened pin, eliminating backlash

Dimensions

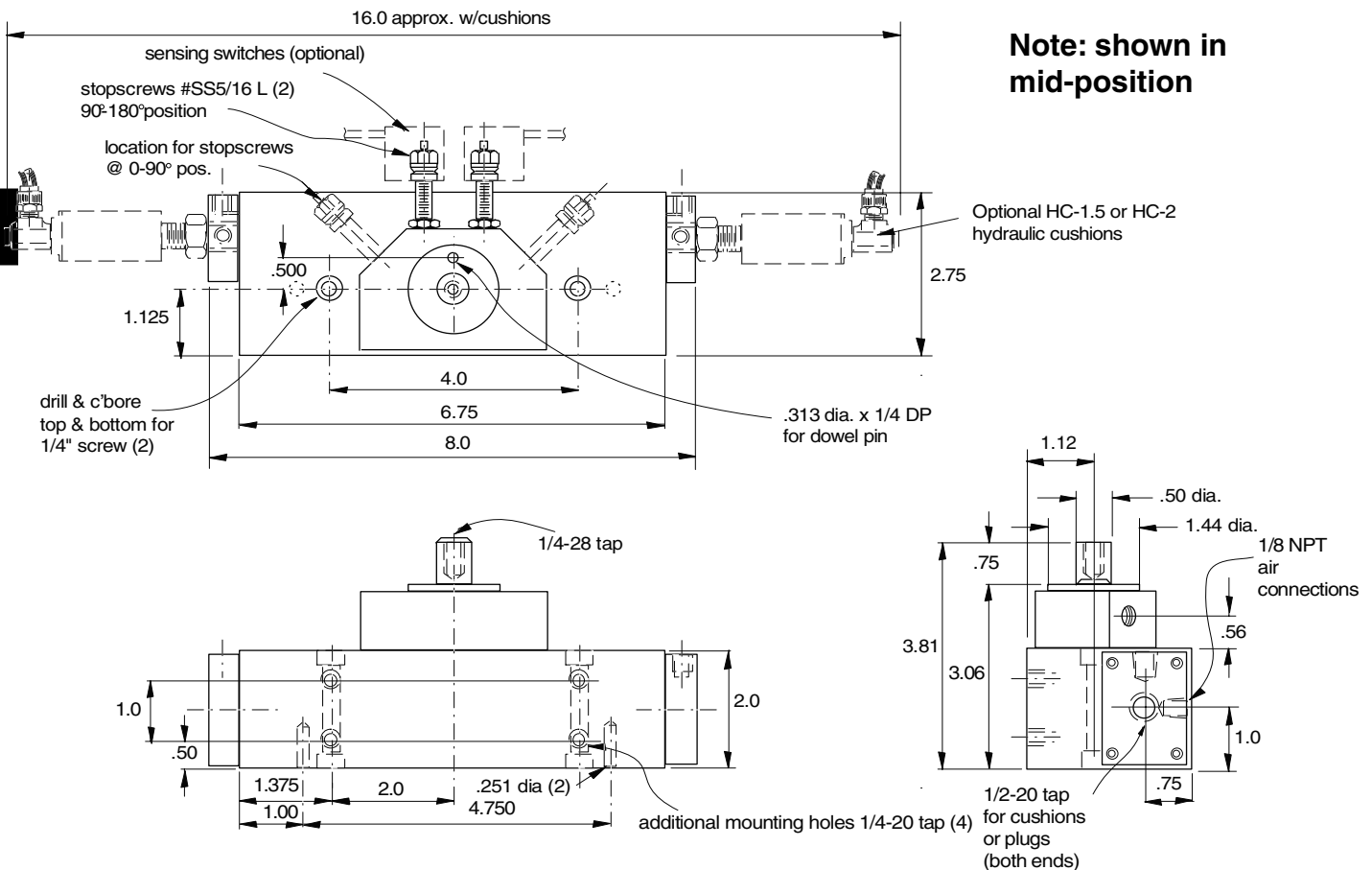

Note: shown in mid-position

RD-3 Rotary Drive

Technical Data

Bore	= 1.25"
Repeat accuracy	= +/-0.0005"
Life expectancy	= 5-6 million cycles
Compressed air	= 60 to 100 psi
Angle of rotation	= 0 to 180 degrees
Weight	= 5 lbs
Air connection	= 10-32
Max radial bearing load	= 20 lbs
Max axial bearing load	= 36 lbs

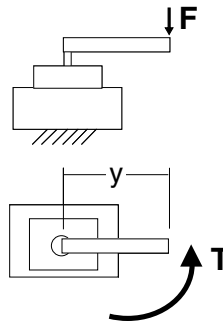

Pressure	Piston Area (in ²)	Max Torque (in-lbs)
60	1.227	33
70	1.227	38
80	1.227	44
90	1.227	49
100	1.227	55

The diagrams above depict the load (F) on an arm of length = y. Also shown is the torque of the RD-3 which is given in the chart:

Load vs. Distance for Different Cycle Times (@80psi)
Load (for any P) = Graph value *(P/80)

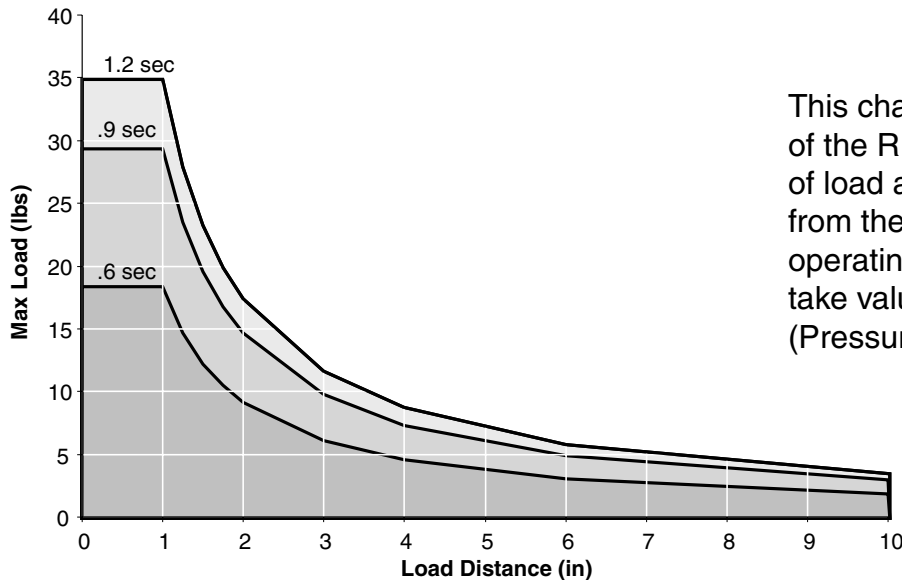

This chart shows how the cycle time of the RD-3 is affected by the amount of load and distance the load is from the shaft, for 180° rotation. For operating pressures other than 80, take value from graph and multiply by (Pressure in psi/80).



Options

Sensing switches are available as an option. They are mounted to the stopscrews as seen in the photo to the right. For specifications on sensing please see page 143. Shocks or cushions are also available.

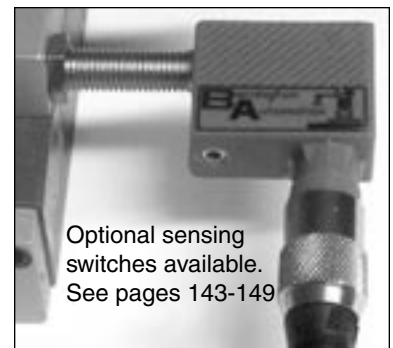

RD-4 Rotary Drive

0-180° Fully Adjustable

Features

- Angle of rotation adjusted with built in stop screws with fine threads
- Stop screws are compatible with sensing switches
- End stops deceleration with available cushions
- Designed for production rates and long life
- Piston has hardened pin to strike for longevity
- Two sealed ball bearings at top and bottom of drive shaft
- Tapped holes and offset dowel pin area in shaft and driving flange allows higher torque transmittal and accuracy



- Bearings are positioned very close to the drive gear for rigidity, precision, wear resistance and accuracy.
- Shaft is stopped with an adjustable hard stopscrew against a hardened pin, eliminating backlash

Dimensions

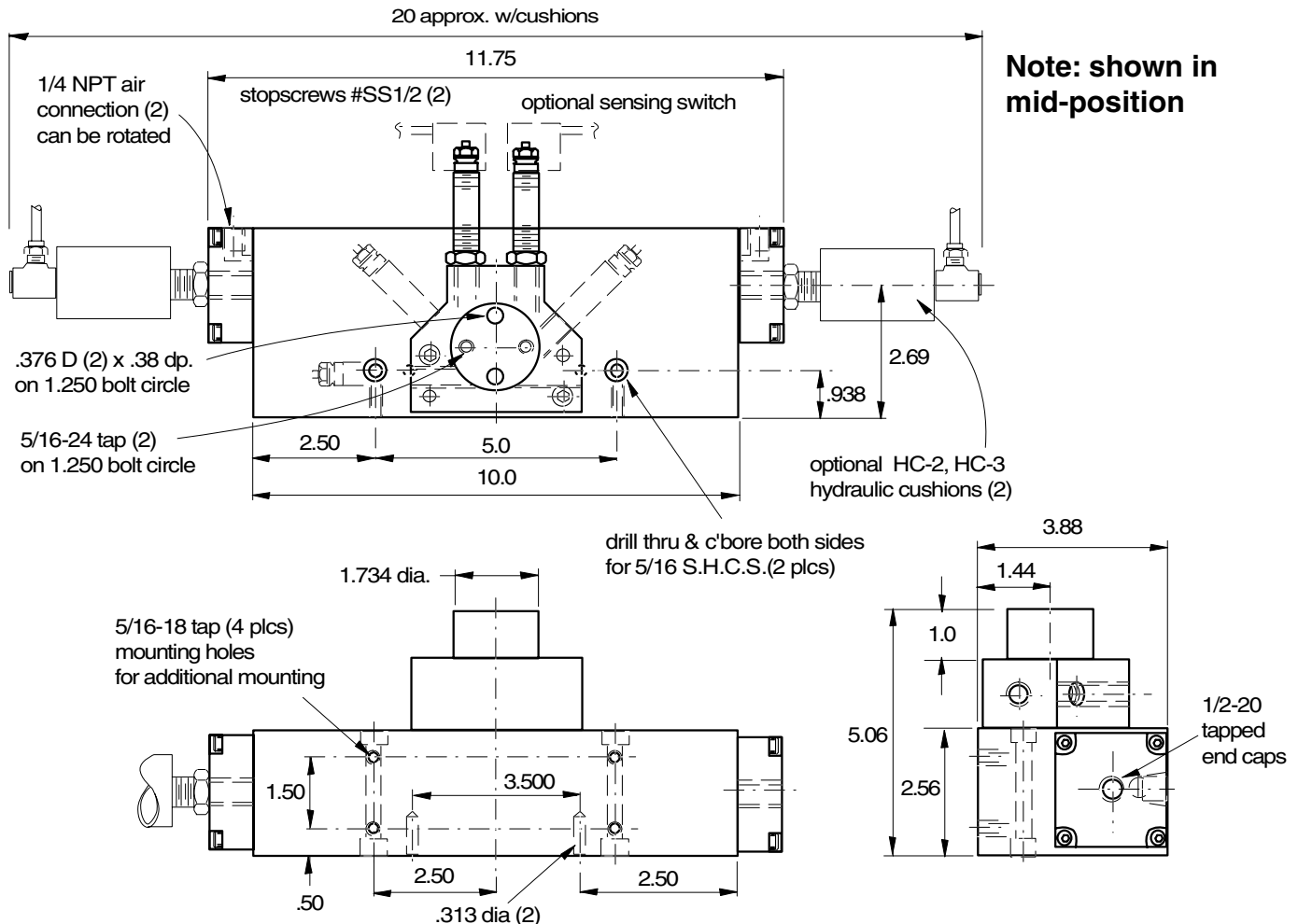

M

RD-4 Rotary Drive

Technical Data

Bore	= 2.00"
Repeat accuracy	= +/-0.0005"
Life expectancy	= 5-6 million cycles
Compressed air	= 60 to 100 psi
Angle of rotation	= 0 to 180 degrees
Weight	= 9.5 lbs
Air connection	= 1/4 NPT
Max radial bearing load	= 60 lbs
Max axial bearing load	= 100 lbs

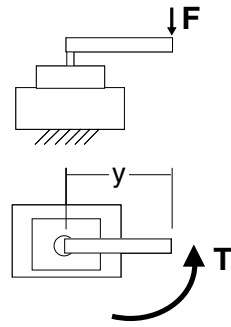

Pressure	Piston Area (in ²)	Max Torque (in-lbs)
60	3.142	130
70	3.142	150
80	3.142	170
90	3.142	190
100	3.142	210

The diagrams above depict the load (F) on an arm of length = y. Also shown is the torque of the RD-4 which is given in the chart:

Load vs. Distance for Different Cycle Times (@80psi)

Load (for any P) = Graph value *(P/80)

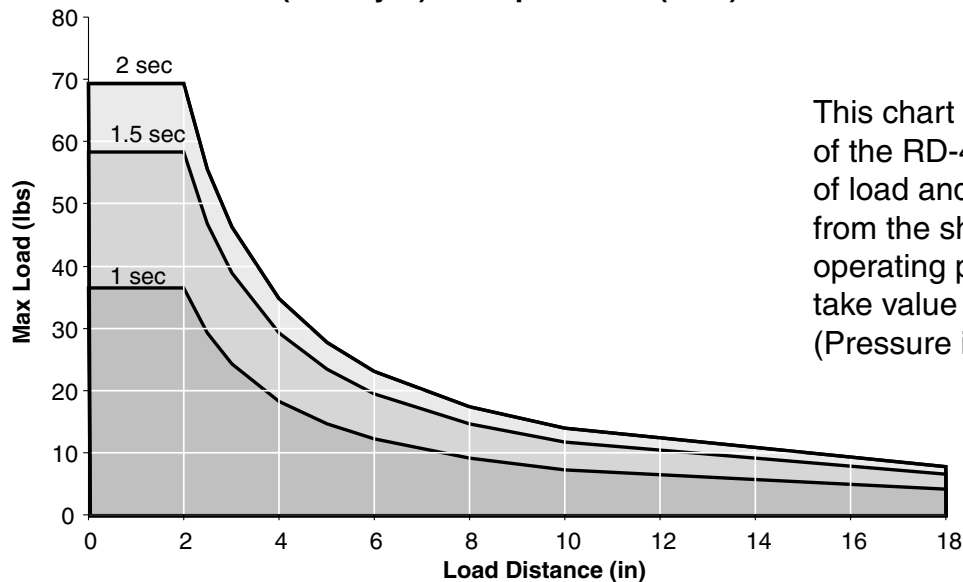

This chart shows how the cycle time of the RD-4 is affected by the amount of load and distance the load is from the shaft, for 180° rotation. For operating pressures other than 80, take value from graph and multiply by (Pressure in psi/80).



Options

Sensing switches are available as an option. They are mounted to the stopscrews as seen in the photo to the right. For specifications on sensing please see page 143. Shocks or cushions are also available.

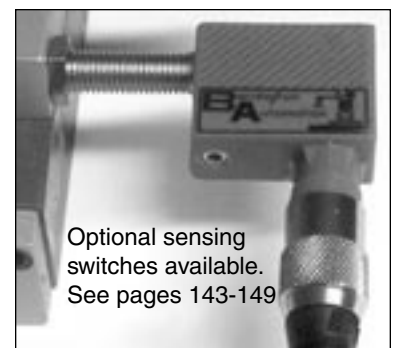

Optional sensing switches available. See pages 143-149