

Mounting Instructions

General Mounting Instructions

General notes

The following installation notes apply to all Roller Rail Systems.

⚠ In overhead mounting orientations (suspended top down) the runner block could possibly come away from the rail due to loss or breakage of rollers. Secure the runner block against falling!

Rexroth roller rail systems are high quality, precision manufactured products and must therefore be handled with the utmost care in transit and during subsequent installation. The same care must be taken with cover strips. All steel parts are treated with anticorrosion oil prior to shipment. It is not necessary to remove this oil provided the recommended lubricants are used.

Parallelism offset of mounted rails

Values measured at the guide rails and at the runner blocks

The parallelism offset P_1 causes a slight increase in preload on one side of the assembly.

As long as the values specified in the table are met, the effect of this on the service life can generally be neglected.

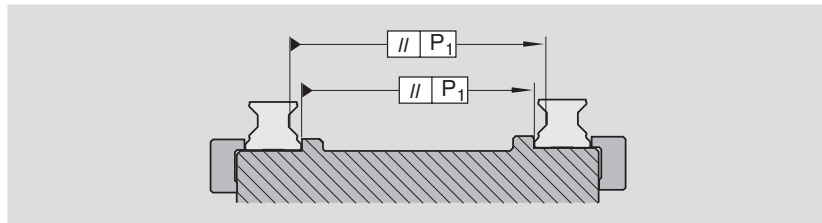

Roller Rail System	Size	Parallelism offset P_1 (mm) for preload class	
		C2	C3
Standard	25	0.007	0.005
	35	0.010	0.007
	45	0.012	0.009
	55	0.016	0.011
	65	0.022	0.016
Wide	55/85	0.016	0.011
	65/100	0.022	0.016
Heavy duty	100	0.029	0.022
	125	0.034	0.026

Preload classes

C2 = preload 8% C

C3 = preload 13% C

Mounting with mounting runner block

The central hole D in the mounting runner block allows precise measurement of the relative rail position. The rail mounting screws can also be driven down through this hole.

Aligning the rails

- Align and mount the first rail using a graduated straightedge.
- Set up a mounting bridge with dial gauge between the runner blocks.
- Move both runner blocks in parallel until hole D in the mounting runner block is positioned precisely above a mounting hole in the rail.
- Align the guide rail manually until the dial gauge shows the correct dimension.
- Then screw down the rail through hole D in the mounting runner block.

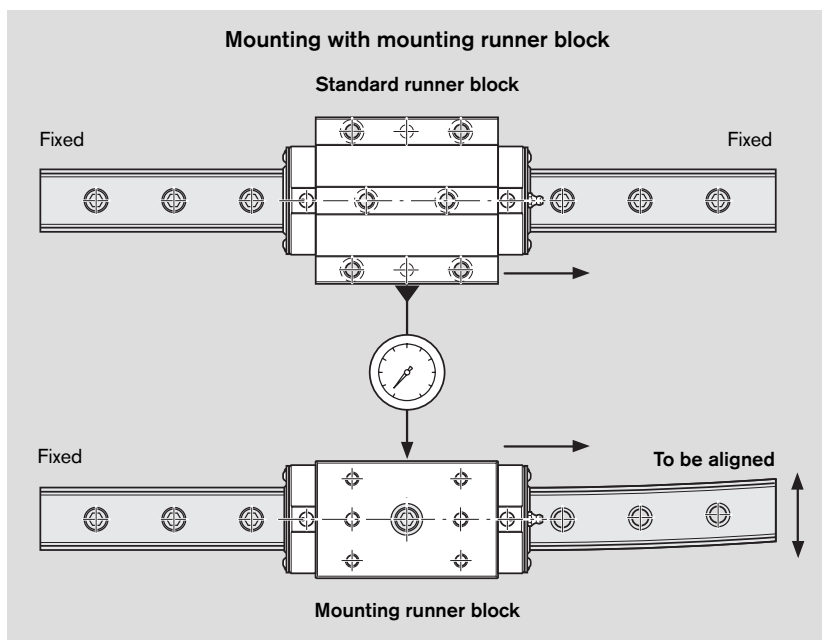

Mounting Instructions

General Mounting Instructions

Vertical offset

Provided the vertical offset is kept within the stated tolerances for S_1 and S_2 , its influence on the service life can generally be neglected.

Permissible vertical offset in the transverse direction S_1

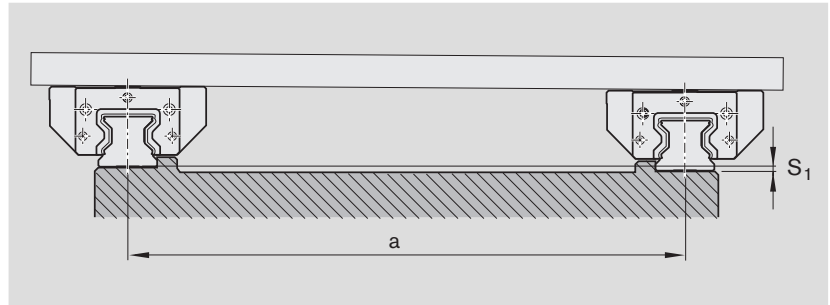

The tolerance for dimension H, as given the table with accuracy classes in the "General Product Description" section, must be deducted from the permissible vertical offset S_1 .

$$S_1 = a \cdot Y$$

S_1 = permissible vertical offset of the guide rails (mm)
 a = distance between guide rails (mm)
 Y = calculation factor

Calculation factor	For preload class	
	C2	C3
Y	$1.7 \cdot 10^{-4}$	$1.2 \cdot 10^{-4}$

Permissible vertical offset in the longitudinal direction S_2

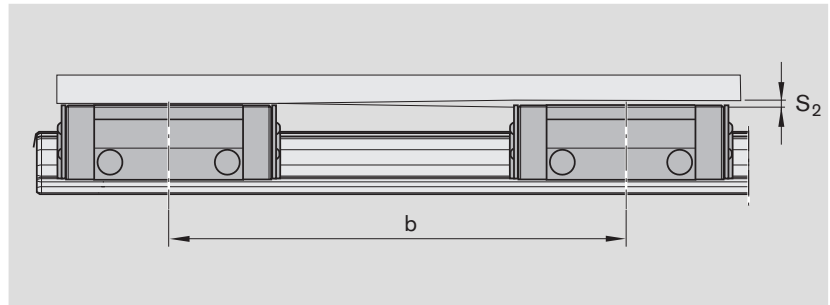

The tolerance "max. difference in dimension H on the same rail", as given the table with accuracy classes in the "General Product Description" section, must be deducted from the permissible vertical offset S_2 .

$$S_2 = b \cdot X$$

S_2 = permissible vertical offset of the runner blocks (mm)
 b = distance between runner blocks (mm)
 X = calculation factor

Calculation factor	For runner block length	
	Standard	Long
X	$4.3 \cdot 10^{-5}$	$3.0 \cdot 10^{-5}$

Runner block with standard length

- Standard roller rail system
FNS R1851, SNH R1821
- Heavy duty roller rail system
FNS R1861

Runner block, long

- Standard roller rail system
FLS R1853, SLH R1824
- Wide roller rail system
BLS R1872
- Heavy duty roller rail system
FLS R1863

Mounting Instructions

General Mounting Instructions

Shipment of guide rails

One-piece guide rails

Standard: One-piece roller guide rails with cover strip are shipped with the cover strip clipped on, both ends angled down and with protective caps screwed on.

If required, guide rails can also be supplied with a separate cover strip.

Composite guide rails

The cover strip and protective caps are supplied complete with screws and washers in a separate packing unit. The packing unit is marked with the same manufacturing job number as the labels on the guide rails.

The cover strips have one angled down and one straight end (strip tongue).

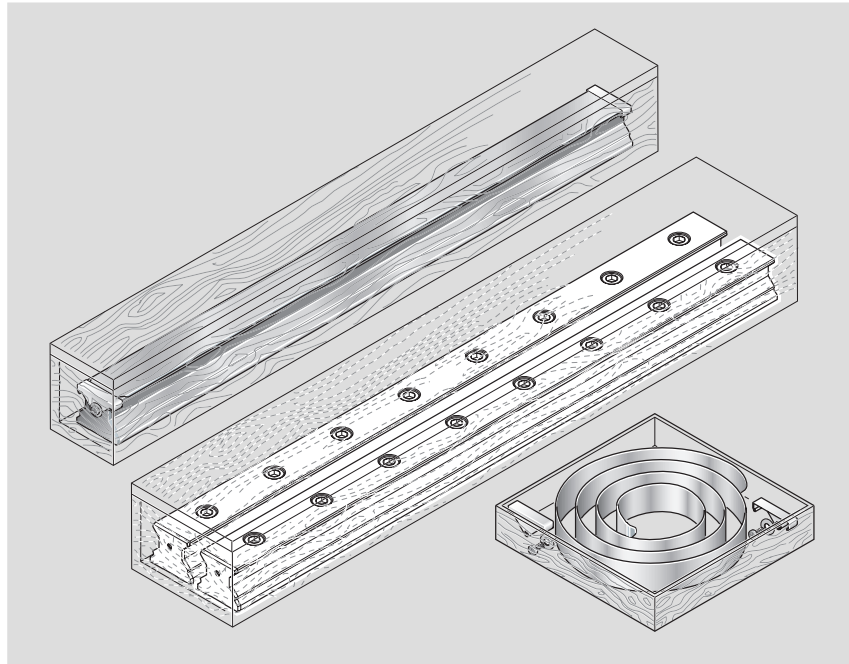

Composite guide rails

Matching sections of a composite guide rail are identified as such by a label on the packaging.

All sections of the same rail have the same number, which is marked on the top of the guide rail.

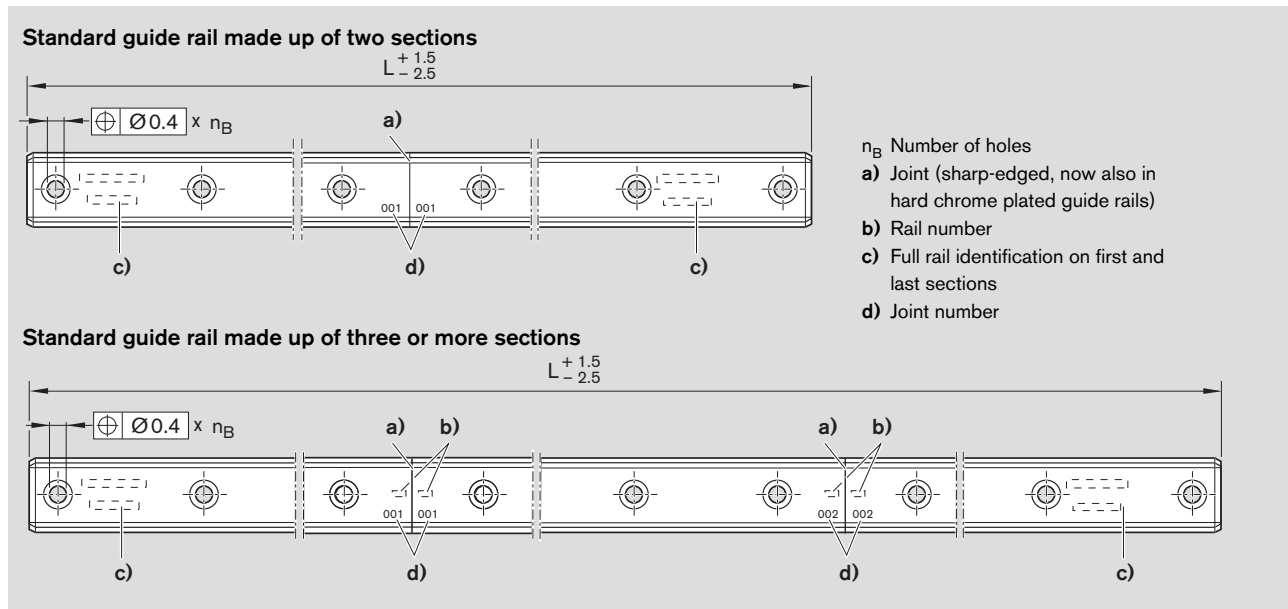

Note on cover strip

For composite rails, a cover strip to cover the total length L is supplied separately along with the rails.

Adjusting shaft

The sections of composite rails can be aligned with the aid of an adjusting shaft. For more detailed information see

“Accessories” and “Mounting Instructions for Roller Rail Systems.”

Mounting Instructions

General Mounting Instructions

Wide guide rail made up of two sections

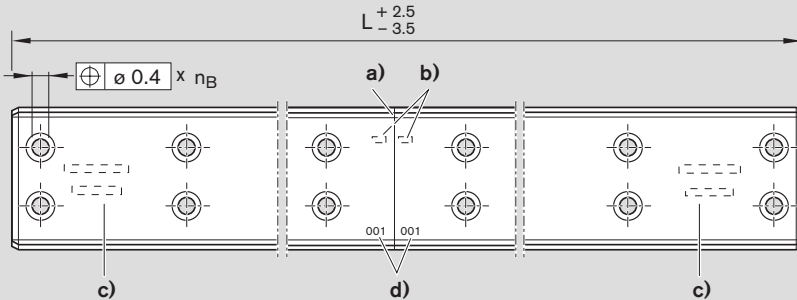

- n_B Number of holes
- a) Joint (sharp-edged, now also in hard chrome plated guide rails)
- b) Rail number
- c) Full rail identification on first and last sections
- d) Joint number

Wide guide rail made up of three or more sections

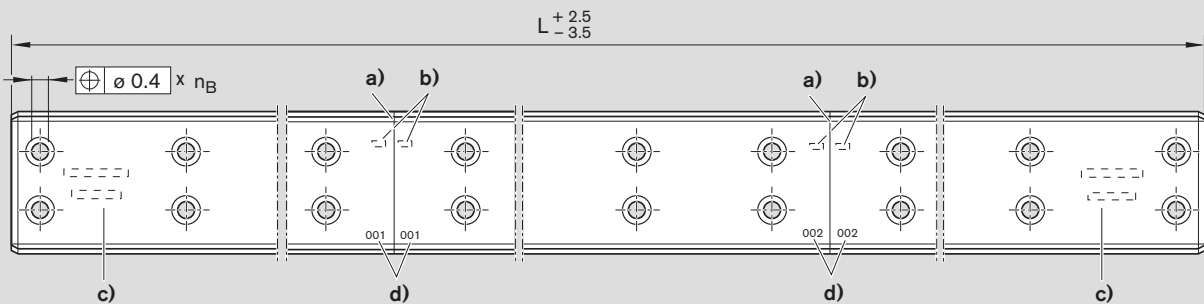

Heavy duty guide rail made up of two sections

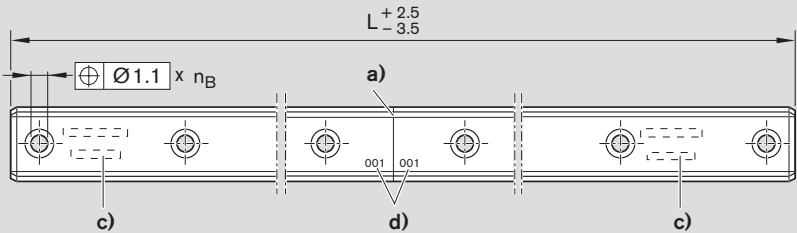

- n_B Number of holes
- a) Joint (sharp-edged, now also in hard chrome plated guide rails)
- b) Rail number
- c) Full rail identification on first and last sections
- d) Joint number

Heavy duty guide rail made up of three or more sections

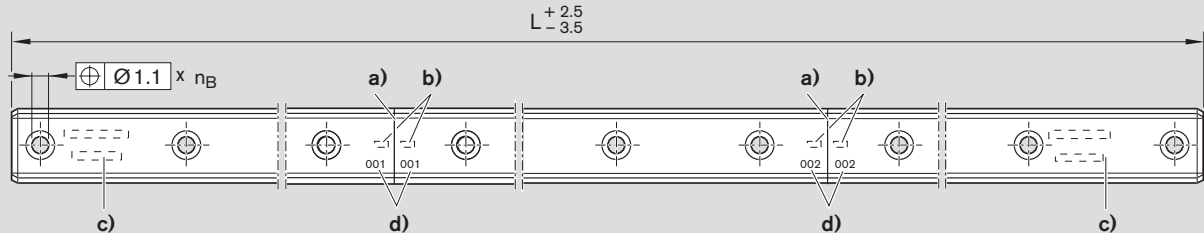

Note on cover strip

For composite rails, a cover strip to cover the total length L is supplied separately along with the rails.

Adjusting shaft

The sections of composite rails can be aligned with the aid of an adjusting shaft. For more detailed information see "Accessories" and "Mounting Instructions for Roller Rail Systems."

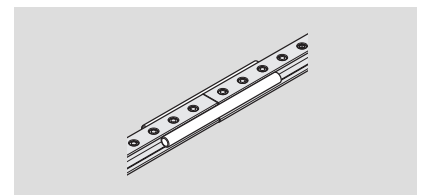

Mounting Instructions

General Mounting Instructions

Mounting examples

Guide rails

Each guide rail has ground reference surfaces on both sides. These are not marked, since each guide rail can be mounted to the left or the right of a reference edge (1) for lateral retention.

Notes

- For guide rails without lateral retention, we recommend using a straight-edge to make sure the rails are properly aligned and parallel during assembly (recommended limits for side load if no additional lateral retention is provided, see "Mounting").
 - Use a mounting runner block (see "General Mounting Instructions").
 - Install mounting hole plugs or a cover strip (see the relevant Mounting Instructions!):
- A** After mounting the guide rails, tap the plastic mounting hole plugs into the screw holes with the aid of a plastic pad until flush with the surface of the rail.
- B** To fit steel mounting hole plugs, always use the special mounting tool (see "Accessories").
The plugs must be flush with the rail surface before mounting the runner block!
- C** For guide rails with cover strip, see "Notes on cover strip."

Runner blocks

Standard and heavy duty runner blocks have one ground reference edge on each side, while wide runner blocks have two (total of four) (dimension V_1 in the dimension drawings).

⚠ Always fit steel mounting hole plugs before pushing on the runner blocks! Before mounting the runner block, oil or grease the sealing lips of the runner block and the bevel on the end face of the guide rail!

- After sliding the runner block onto the rail, check that it moves easily.

⚠ Then apply initial lubrication (see "Lubrication" section)!

- Detailed information on the mounting procedure can be found in "Mounting Instructions for Roller Rail Systems."

Lateral retention of the guide rails and/or runner blocks (examples)

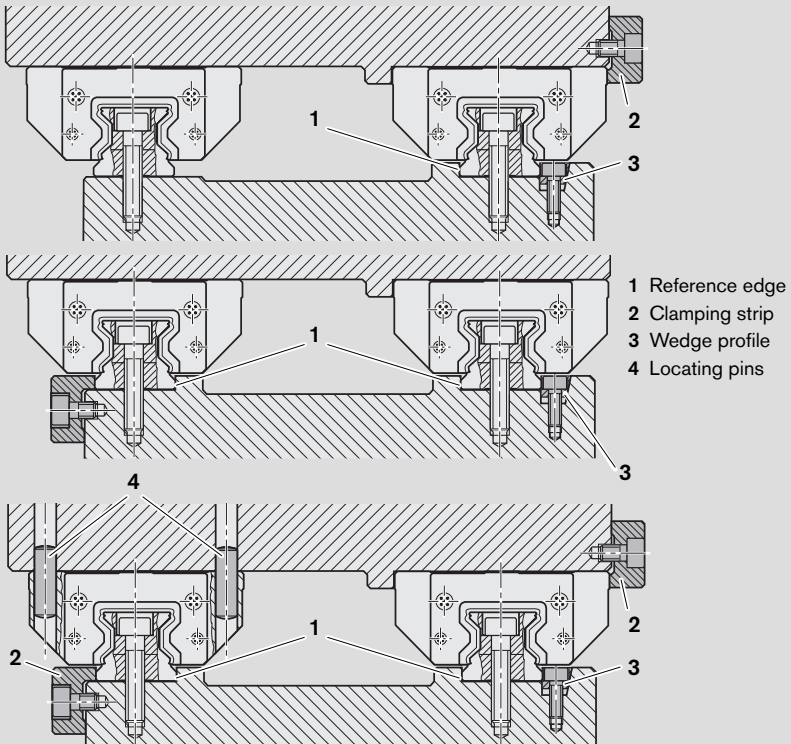

Installing mounting hole plugs or a cover strip to the guide rail

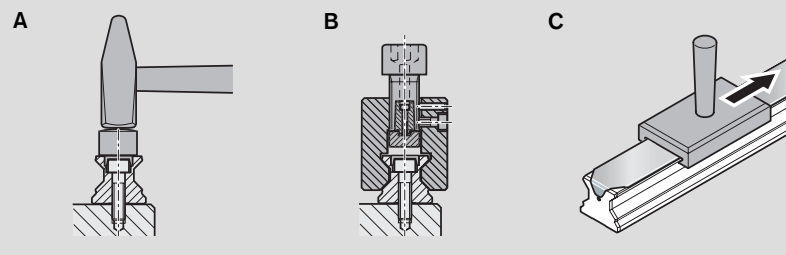

Mounting the runner block

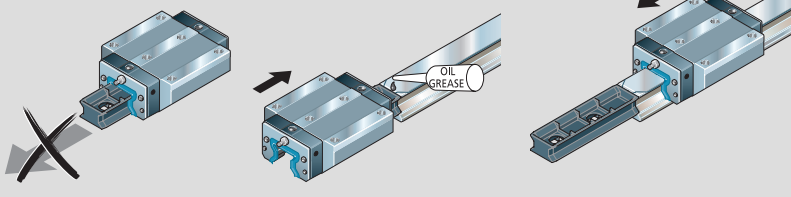

⚠ The transport and mounting arbor must remain in the runner block until the block is pushed onto the guide rail. Otherwise, rollers may be lost!

⚠ Use the mounting arbor again to remove runner blocks from the rail! When not installed on the guide rails, the runner blocks should always be kept on the arbor!

Mounting Instructions

Mounting

Load on the screw connections between the guide rail and the mounting base

The high-performance capability of Roller Rail Systems permits the load limits for screw connections as specified in DIN 645-1 to be exceeded. The most critical point is the screw connection between the guide rail and the mounting base. Screw connections for which the loads F or moment loads M_t exceed the relevant load limits in the table must be separately recalculated (see VDI Guideline 2230).

The values shown in the table apply under the following conditions:

- Mounting screws quality 12.9
- Screws tightened with a torque wrench
- Screws lightly oiled (for screws in quality 8.8, an approximation factor of 0.6 can be applied).
- Parts screwed down to steel or cast iron bases
- Screw-in depth at least 2x thread diameter

Standard roller rail systems

Guide rail	Size	Static lift-off loads F and moment loads M_t			
		Runner block, standard length SNH R1821, FNS R1851		Runner block, long SLH (SLS) R1824, FLS R1853	
		F_{max} N	$M_{t,max}$ Nm	F_{max} N	$M_{t,max}$ Nm
R1805	25	34 300	360	39 200	410
R1806	35	64 500	1 030	73 800	1 180
R1845	45	157 800	3 390	180 400	3 870
	55	216 800	5 400	247 800	6 100
	65	296 000	8 900	339 400	10 100
R1807	25	34 300	360	39 200	410
R1847	35	64 500	1 030	73 800	1 180
	45	157 800	3 390	180 400	3 870
	55	216 800	5 400	247 800	6 100
	65	296 000	8 900	339 400	10 100

Wide roller rail systems

Guide rail	Size	Static lift-off loads F and moment loads M_t	
		F_{max} N	$M_{t,max}$ Nm
R1875	55/85	360 000	10 100
R1873	65/100	494 000	16 500

Heavy duty roller rail systems

Guide rail	Size	Static lift-off loads F and moment loads M_t			
		Runner block, standard length FNS R1861		Runner block, long FLS R1863	
		F_{max} N	$M_{t,max}$ Nm	F_{max} N	$M_{t,max}$ Nm
R1835	100	686 000	33 270	784 000	38 000
R1865	125	1 102 500	66 150	1 260 000	75 600

Guide rail for mounting from above

Standard: R1805, R1806, R1845
Wide: R1875, R1873
Heavy duty: R1835, R1865

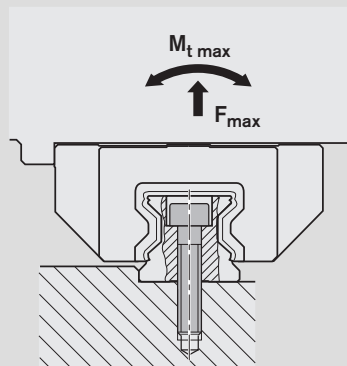

Guide rail for mounting from below

Standard: R1807, R1847

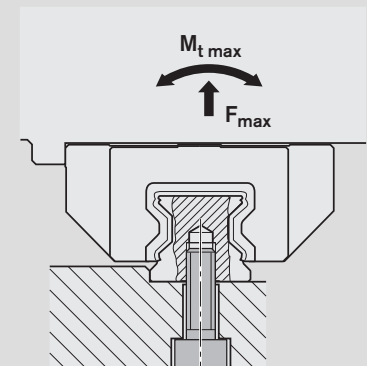

Mounting Instructions

Mounting

Standard Roller Rail Systems

Reference edges and corner radii

Combination examples

The combinations shown here are examples. Basically, any runner block may be combined with any of the rail types offered.

Mounting and lubrication

For details of runner block and guide rail mounting, see "General Mounting Instructions."

For initial and in-service lubrication, see "Lubrication."

Detailed information on the mounting procedure can be found in "Mounting Instructions for Roller Rail Systems."

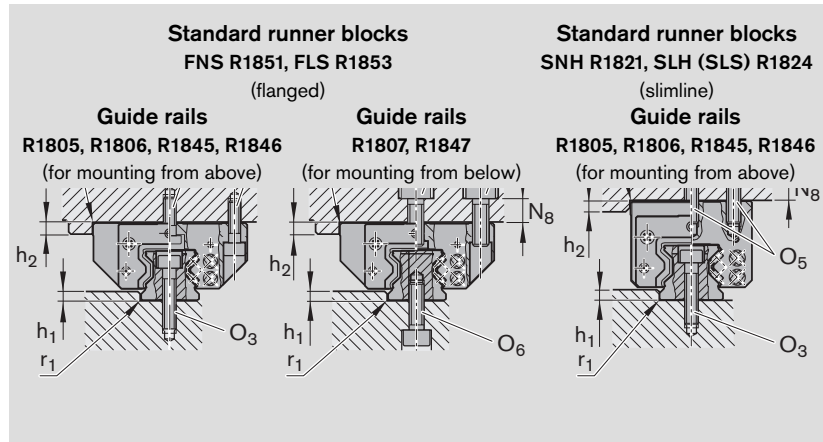

Size	Dimensions (mm)					
	h_1 min	h_1 max ¹⁾	h_2	N_8	r_1 max	r_2 max
25	3.0	4.5	5	10	0.8	0.8
35	3.5	5.0	6	13	0.8	0.8
45	4.5	7.0	8	14	0.8	0.8
55	7.0	9.0	10	20	1.2	1.0
65	7.0	9.0	14	22	1.2	1.0

1) When using braking and clamping units, please take account of the values H_1 from the "Braking and Clamping Units" catalog.

Mounting screws

⚠ Always check the strength factor of the screws in the case of high lift-off loads!

Please refer to the section "Load on the screw connections between the guide rail and the mounting base."

Size	Screw sizes					
	Runner block				Guide rail	
	O_1	O_2 ¹⁾	O_4 ^{1) 2)}	O_5	O_3	O_6
	ISO 4762	DIN 6912	ISO 4762	ISO 4762	ISO 4762	ISO 4762
	4 pieces	2 pieces	6 pieces	6 pieces		
25	M6x20	M6x16	M8x20	M6x18	M6x30	M6x20
35	M8x25	M8x20	M10x25	M8x25	M8x35	M8x25
45	M10x30	M10x25	M12x30	M10x30	M12x45	M12x30
55	M12x40	M12x30	M14x40	M12x35	M14x50	M14x40
65	M14x45	M14x35	M16x45	M16x40	M16x60	M16x45

- For runner block mounting using 6 screws:
Tighten the centerline screws O_2 , O_4 or O_5 with the tightening torque for strength class 8.8.
- For runner block mounting from above with only 4 O_4 screws:
Permissible side load 1/3 lower, and lower rigidity

Permissible side load

The recommended limits for permissible side loads without additional lateral retention indicate the approximate upper limits for screws in two strength classes.

In other cases, the permissible side load must be calculated from the screw tension force. This can be up to about 15% less when using screws in strength class 10.9 instead of 12.9.

Screw strength class	Permissible side load without lateral retention ¹⁾					
	Runner block				Guide rail	
	O_1	O_2	O_4	O_5	O_3	O_6
8.8 ²⁾	9% C	13% C ⁴⁾	20% C	13% C	10% C	10% C
8.8 ³⁾	7% C	11% C ⁴⁾	16% C	11% C	7% C	7% C
12.9 ²⁾	15% C	19% C ⁴⁾	30% C	22% C	17% C	17% C
12.9 ³⁾	12% C	16% C ⁴⁾	23% C	18% C	12% C	12% C

- Calculated with friction coefficient $\mu = 0.125$
- Runner blocks FNS, SNH
- Runner blocks FLS, SLH
- For mounting with 2 O_2 screws and 4 O_1 screws

Recommended tightening torques

For $\mu_k = \mu_G = 0.125$

Strength class	Nm max	M6	M8	M10	M12	M14	M16
		8.8	9.5	23	46	80	125
10.9		13.0	32	64	110	180	275
12.9		16.0	39	77	135	215	330

Mounting Instructions

Mounting

Locating pins

⚠ If the recommended limits for permissible side loads are exceeded, the runner block must be additionally fixed!

Possible pin types

- Taper pin (hardened) or
- Straight pin ISO 8734

Notes

Rough-drilled holes made for production reasons may exist at the recommended pin hole positions on the runner block centerline (dia. $< S_{10}$). These may be bored open to accommodate the locating pins.

If the locating pins have to be driven in at another point, dimension E_2 must not be exceeded in the longitudinal direction (for dimension E_2 , see the tables for the individual runner block types). Observe dimensions E_1 and E_4 !

Standard Roller Rail Systems

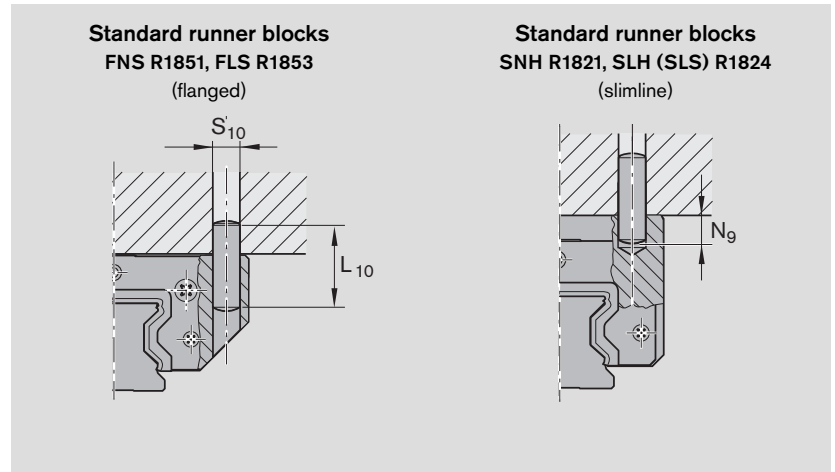

Size	Dimensions (mm)				
	E_1	E_4	$L_{10}^{1)}$	$N_{9 \max}$	$S_{10}^{1)}$
25	35	55	32	9	6
35	50	80	40	13	8
45	60	98	50	18	10
55	75	114	60	19	12
65	76	140	60	22	14

1) Taper pin (hardened) or straight pin (ISO 8734)

Mounting Instructions

Mounting

Wide Roller Rail Systems

Reference edges and corner radii

Mounting and lubrication

For details of runner block and guide rail mounting, see "General Mounting Instructions."

For initial and in-service lubrication, see "Lubrication."

Detailed information on the mounting procedure can be found in "Mounting Instructions for Roller Rail Systems."

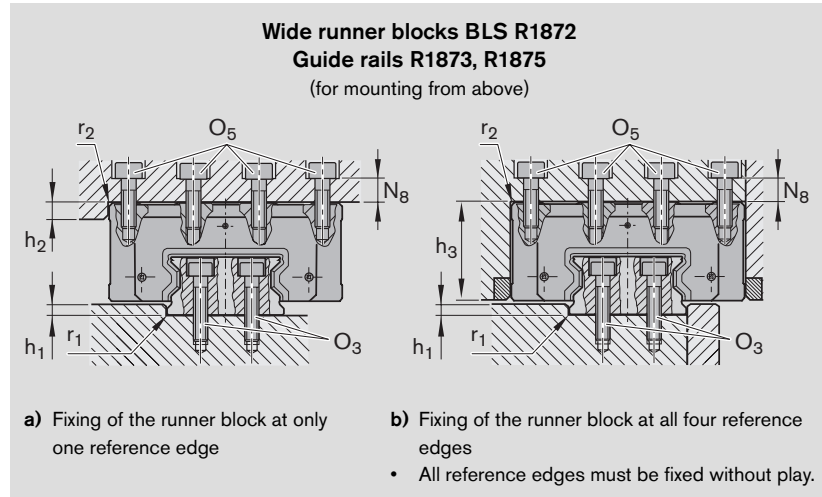

Size	Dimensions (mm)						
	$h_{1 \min}$	$h_{1 \max}$	h_2	h_3	N_8	$r_{1 \max}$	$r_{2 \max}$
55/85	7.0	9.0	10	84	14	1.2	1.0
65/100	7.0	9.0	14	66.5	20	1.2	1.0

Mounting screws

⚠ Always check the strength factor of the screws in the case of high lift-off loads!

Please refer to the section "Load on the screw connections between the guide rail and the mounting base."

Size	Screw sizes	
	Runner block O_5 ISO 4762 6 pieces	Guide rail O_3 ISO 4762
55/85	M12x50	M12x30
65/100	M14x60	M14x35

Permissible side load

The recommended limits for permissible side loads without additional lateral retention indicate the approximate upper limits for screws in two strength classes. In other cases, the permissible side load must be calculated from the screw tension force. This can be up to about 15% less when using screws in strength class 10.9 instead of 12.9.

Screw strength class	Permissible side load without lateral retention ¹⁾	
	Runner block O_5	Guide rail O_3
8.8	16% C ²⁾	16% C
12.9	27% C ²⁾	27% C

1) Calculated with friction coefficient $\mu = 0.125$

2) For runner block mounting using 8 screws

Recommended tightening torques

For $\mu_K = \mu_G = 0.125$

	Nm max	M12	M14
		8.8	80
10.9		110	180
12.9		135	215

Mounting Instructions

Mounting

Reference edges and corner radii

Mounting and lubrication

For details of runner block and guide rail mounting, see "General Mounting Instructions."

To facilitate the mounting of heavy duty runner blocks on the rail, a mounting aid is available on request (see "Accessories").

For initial and in-service lubrication, see "Lubrication."

Detailed information on the mounting procedure can be found in "Mounting Instructions for Roller Rail Systems."

Heavy Duty Roller Rail Systems

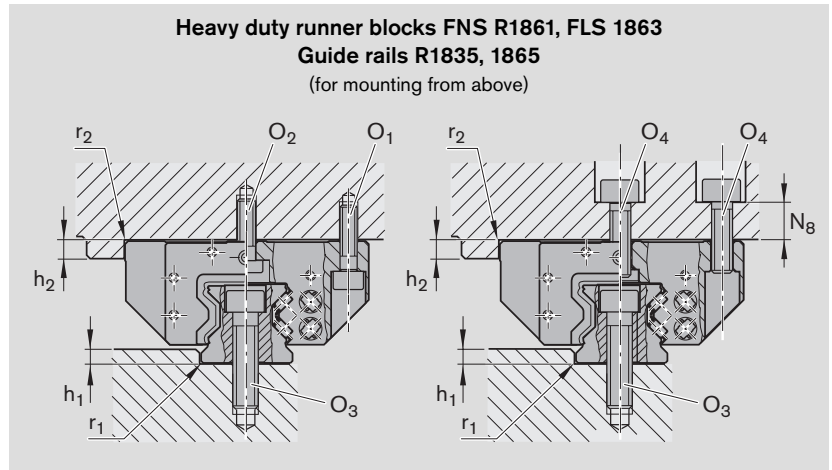

Size	Dimensions (mm)					
	$h_{1 \min}$	$h_{1 \max}$	h_2	N_8	$r_{1 \max}$	$r_{2 \max}$
100	10	14	18	30	1.8	1.3
125	15	20	23	40	1.8	1.8

Mounting screws

⚠ Always check the strength factor of the screws in the case of high lift-off loads!

Please refer to the section "Load on the screw connections between the guide rail and the mounting base."

Size	Screw sizes			Guide rail O_3 ISO 4762
	Runner block			
	O_1 ISO 4762 6 pieces	$O_2^{1)}$ DIN 6912 3 pieces	$O_4^{1) 2)}$ ISO 4762 9 pieces	
100	M16x60	M16x55	M20x60	M24x100
125	M24x85	M24x70	M27x80	M30x120

- For runner block mounting using 9 screws:
Tighten the centerline screws O_2 , or O_4 along the rail with the tightening torque for strength class 8.8.
- For runner block fixing from above using only 6 O_4 screws:
Permissible side load 1/3 lower, and lower rigidity

Permissible side load

The recommended limits for permissible side loads without additional lateral retention indicate the approximate upper limits for screws in two strength classes. In other cases, the permissible side load must be calculated from the screw tension force. This can be up to about 15% less when using screws in strength class 10.9 instead of 12.9.

Screw strength class	Permissible side load without lateral retention ¹⁾			Guide rail O_3
	Runner block O_1	O_2	O_4	
8.8 ²⁾	9% C	13% C ⁴⁾	20% C	10% C
8.8 ³⁾	7% C	11% C ⁴⁾	16% C	7% C
12.9 ²⁾	15% C	19% C ⁴⁾	30% C	17% C
12.9 ³⁾	12% C	16% C ⁴⁾	23% C	12% C

- Calculated with friction coefficient $\mu = 0.125$
- Runner block FNS R1861
- Runner block FLS R1863
- For mounting with 3 O_2 screws and 6 O_1 screws

Recommended tightening torques

For $\mu_K = \mu_G = 0.125$

Screw strength class	Nm max	M16	M20	M24	M27	M30
		8.8	195	390	660	980
10.9		280	560	930	1 400	1 850
12.9		330	650	1 100	1 650	2 250