

Precision Modules PSK

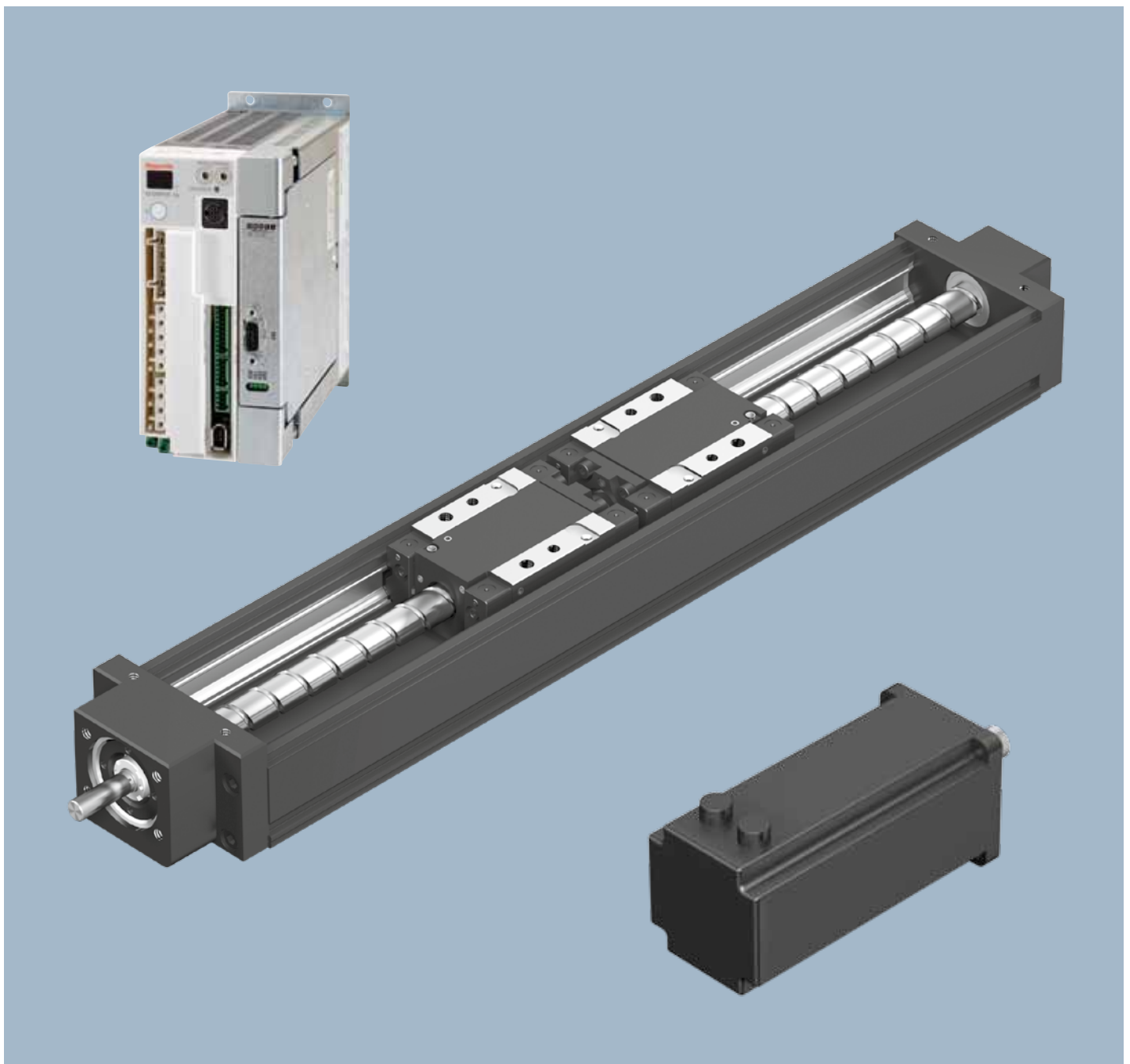

Linear Motion and Assembly Technologies

- Ball Rail Systems
- Roller Rail Systems
- Linear Bushings and Shafts
- Ball Screw Drives
- Linear Motion Systems
- Basic Mechanical Elements
- Manual Production Systems
- Transfer Systems

Ball Rail Systems

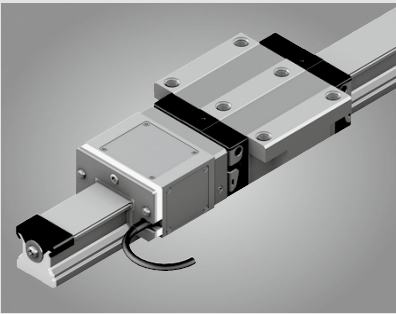

Roller Rail Systems

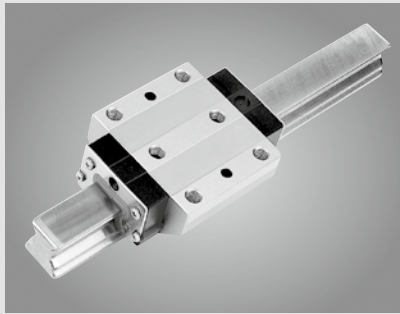

Linear Bushings and Shafts



Ball Screw Drives



Linear Motion Systems

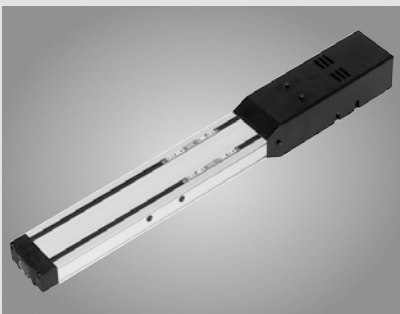

Basic Mechanical Elements

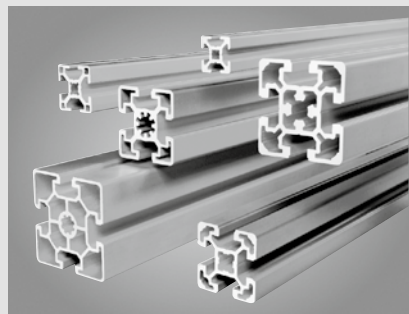

Manual Production Systems



Assembly Conveyors

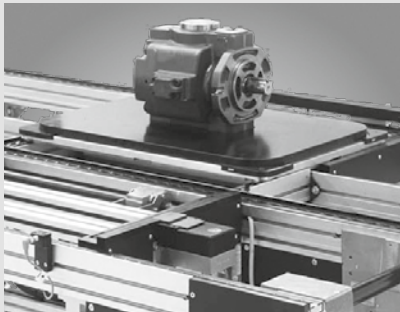

VarioFlow Conveyors



Precision Modules PSK

Product Description	4	Switch Mounting Arrangements	56
Product Overview	6	Motors	59
Motor selection	6	AC Servo Motors MSK	59
Overview of types with load capacities	8	AC Servo Motors MSM	60
Dimensions	9	3-phase Stepping Motors VRDM	61
Structural Design	10	Mounting	62
PSK without cover	10	Lube Ports	63
PSK with cover plate	10	Documentation	64
PSK with sealing strip	11	Inquiry/Order Form	67
Attachments for all PSK modules	11		
Technical Data	14		
Technical Data, Calculations	20		
Calculation Example	23		
Accuracy	25		
Precision Module PSK 40	26		
Components and Ordering Data	26		
Lengths and Hole Spacing	28		
Dimension Drawings without Cover	29		
Dimension Drawings with Cover Plate	30		
Dimension Drawings, Motor Attachment	31		
Precision Module PSK 50	32		
Components and Ordering Data	32		
Lengths and Hole Spacing	34		
Dimension Drawings without Cover	35		
Dimension Drawings with Cover Plate	36		
Dimension Drawings with Sealing Strip	37		
Dimension Drawings, Motor Attachment	38		
Precision Module PSK 60	40		
Components and Ordering Data	40		
Lengths and Hole Spacing	42		
Dimension Drawings without Cover	43		
Dimension Drawings with Cover Plate	44		
Dimension Drawings with Sealing Strip	45		
Dimension Drawings, Motor Attachment	46		
Precision Module PSK 90	48		
Components and Ordering Data	48		
Lengths and Hole Spacing	50		
Dimension Drawings without Cover	51		
Dimension Drawings with Cover Plate	52		
Dimension Drawings with Sealing Strip	53		
Dimension Drawings, Motor Attachment	54		

Product Description

Outstanding features

Rexroth Precision Modules are precise, ready-to-install linear motion systems that combine high performance with compact dimensions.

Rexroth offers favorable price/performance ratios and fast delivery.

Structural design

- Extremely compact and rigid precision steel profile (frame) with reference edge and integrated Rexroth guideway geometry
- Precision ball screw drive in tolerance grade 7 with zero-backlash nut system
- Aluminum fixed bearing end block with preloaded ball bearings and ball screw journal
- Floating bearing end block with double ball bearings
- One or two steel carriages, standard length or long, for PSK without cover or with cover plate
- One aluminum carriage, standard length or long, for PSK with sealing strip

Attachments

- Maintenance-free digital AC servo drives with integrated brake and attached feedback, or stepping motors
- Motor mount and coupling or timing belt side drive for motor attachment
- Adjustable switches over the entire travel range
- Aluminum profile cable duct

Drive controllers and control systems

Further highlights

- Extremely stiff and precise miniature drive unit
- Optimal travel performance, high load capacities, high precision and high rigidity due to integrated Rexroth Ball Rail System
- High positioning accuracy and repeatability due to Precision Ball Screw Assembly with zero-backlash nut system
- Repeatability up to 0.005 mm
Positioning accuracy up to 0.01 mm
Guidance accuracy up to 0.005 mm
- High travel speeds combined with high precision due to Ball Rail Systems, large screw diameters and leads, and double floating bearing
- Rapid mounting and easy axis alignment thanks to machined reference edge on the frame
- Precise alignment and secure mounting of attachments thanks to tapped bores and pin holes in the carriage
- Easy motor attachment via locating feature and fastening threads
- Low-cost maintenance provided by one-point lubrication (grease) for Ball Rail System and Precision Ball Screw Assembly
- Precision Modules in standard lengths for fast delivery

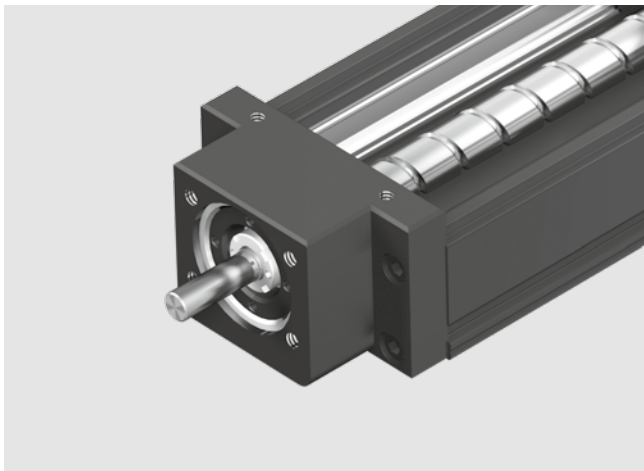

Fixed bearing end block with ball screw journal

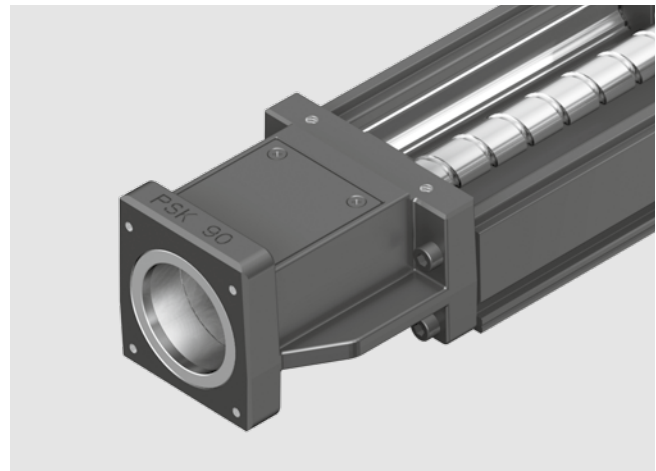

Fixed bearing end block with integrated motor mount

For mounting, maintenance and start-up, see "Instructions for Precision Modules PSK."

PSK without cover

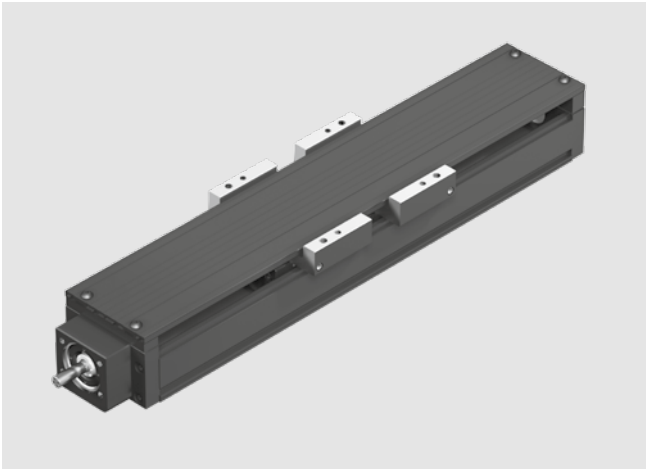
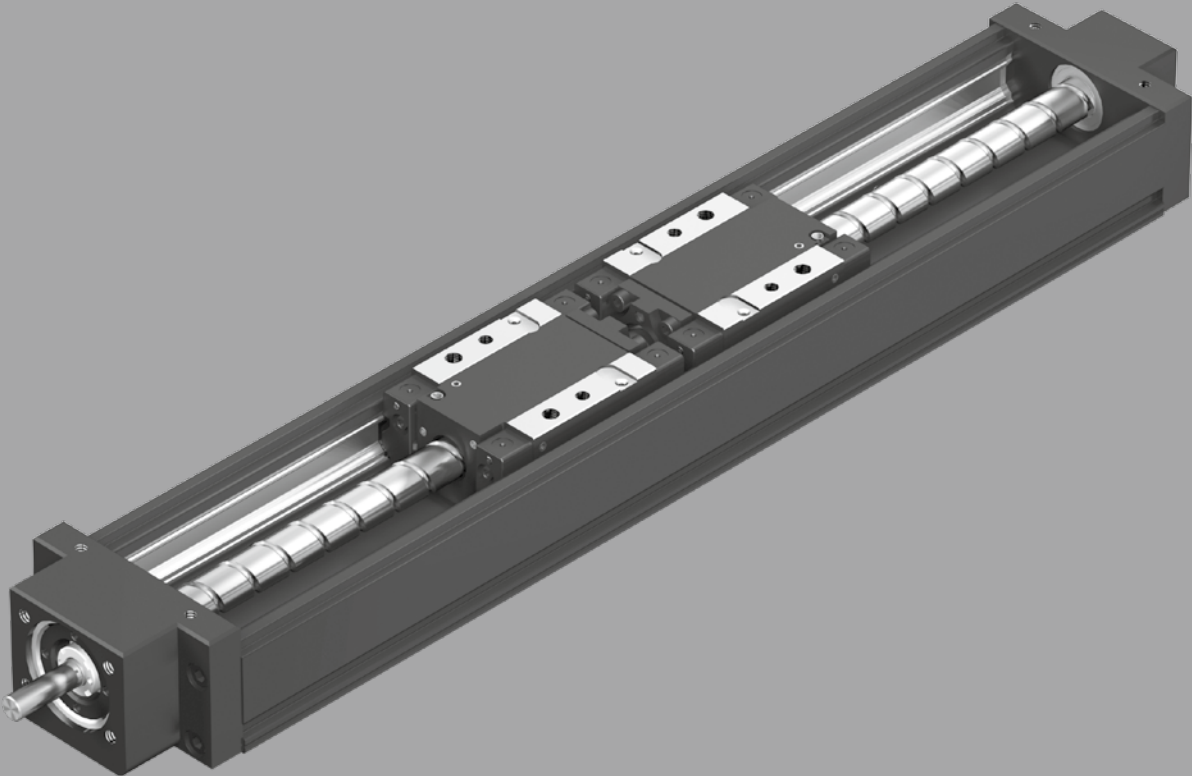

Internal elements protected by cover plate
One or two steel carriages, standard length or long

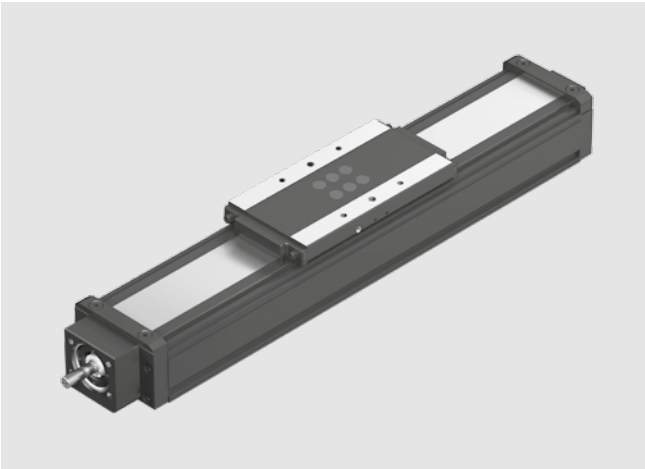

Internal elements protected by stainless steel sealing strip
Aluminum carriage, standard length or long

Product Overview

Motor selection

Based on drive controllers and control system

A choice can be made between several different motor/controller combinations to achieve the most cost-efficient solution for each customer application. When sizing the drive, always consider the motor-controller combination. For more information about motors and control systems, see the following Rexroth catalog:
- IndraDrive for Linear Motion Systems



Digital AC servo motors MSK

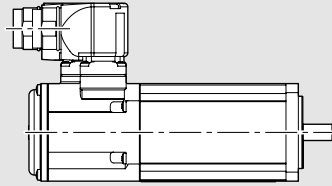

Digital controllers IndraDrive

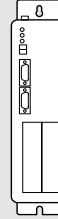

Digital AC servo motors MSM

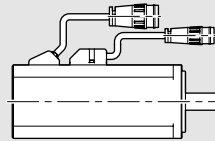

Digital controllers ECODRIVE Cs

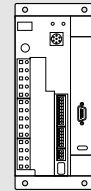

3-phase stepping motors VRDM

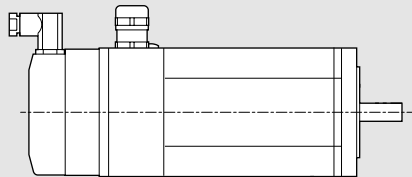

Power electronics

SD326
SD328

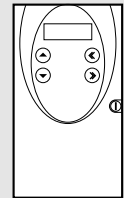

Twin Line

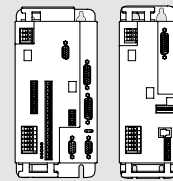

Profi Step control unit

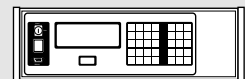



Precision Modules PSK can be supplied complete with motor, drive and control unit.

Product Overview

Type designation (size)

Precision Modules are designated according to type and size. Types also cover the equivalent designs without drive systems.

Description	Type			Size
	P	S	K	
Example: Precision Module				60
System	Precision Module (P)			
Guideway	Integrated Ball Rail System (S)			
Drive unit	Precision Ball Screw Assembly (K)			
Frame size	Approx. width of frame (mm) Example: B = 60 mm			

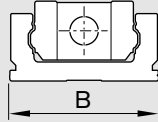

Overview of types with load capacities

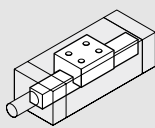
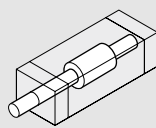
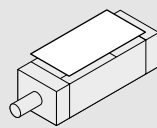
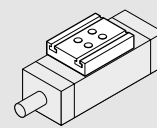
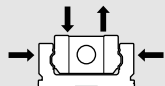
Type	System	Guideway 	Drive unit ¹⁾ 	Size	Cover 	Carriage (carr.) 	Load capacities 	
							Number	C (N)
PSK	Precision Module	Rail System	Precision Ball Screw Assembly	PSK 40	Without / cover plate	Standard	1 carr.	3 065
							2 carr.	4 980
				PSK 50	Without / cover plate	Standard	1 carr.	7 300
							2 carr.	11 850
					Sealing strip	Standard	1 carr.	7 300
							Long	11 850
				PSK 60	Without / cover plate	Standard	1 carr.	7 300
							2 carr.	11 850
							Long	1 carr.
					Sealing strip	Standard	2 carr.	14 620
							1 carr.	9 000
							Long	1 carr.
PSK 90	Without / cover plate	Standard	1 carr.	21 300				
			2 carr.	34 600				
	Sealing strip	Long	1 carr.	27 500				
			2 carr.	44 670				
Standard	1 carr.	21 300						
	Long	1 carr.	34 600					

1) All Precision Modules can also be supplied without drive unit.

Permissible loads

Suitable loads (recommended values)

With respect to the desired service life, loads up to about 20% of the characteristic dynamic values (C, M_p, M_L) have proved acceptable.

At the same time, the following may not be exceeded:

- maximum permissible loads
- permissible drive torque
- permissible travel speed

For permissible values, see the "Technical Data" section.

Dimensions

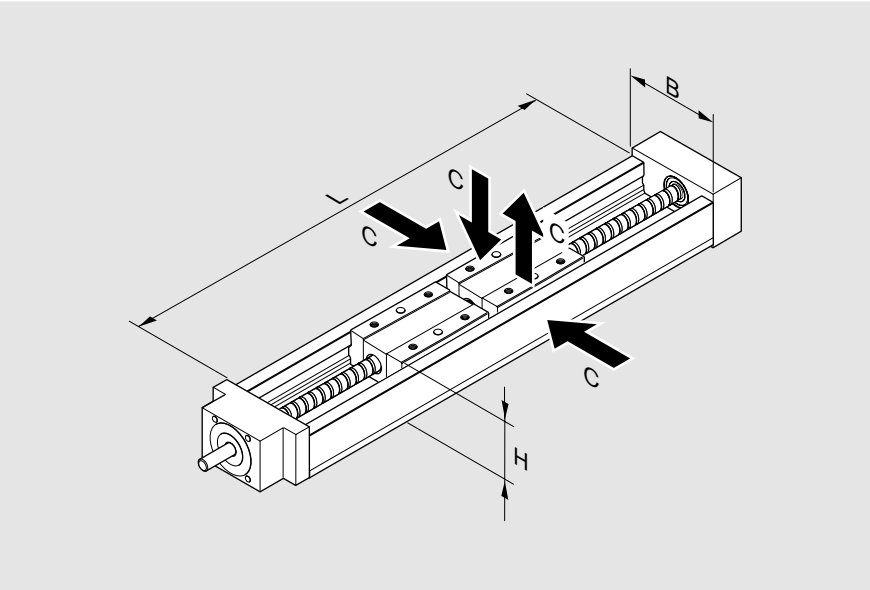

Standard lengths L

Precision Module	PSK 40	PSK 50	PSK 60	PSK 90
B (mm)	40	50	60	86
H (mm)	20	26	33	46
L (mm)	100	100	150	340
	150	150	200	440
	200	200	250	540
	250	250	300	640
	300	300	400	740
	350	350	500	840
		400	600	940
		450	700	
		500	800	
		550	900	
		600	940	

Structural Design

PSK without cover

- 1 Fixed bearing end block
- 2 Ball screw with zero-backlash cylindrical single nut
- 3 One or two steel carriages, standard length or long
- 4 Floating bearing end block
- 5 Frame with reference edge and integrated guideway geometry

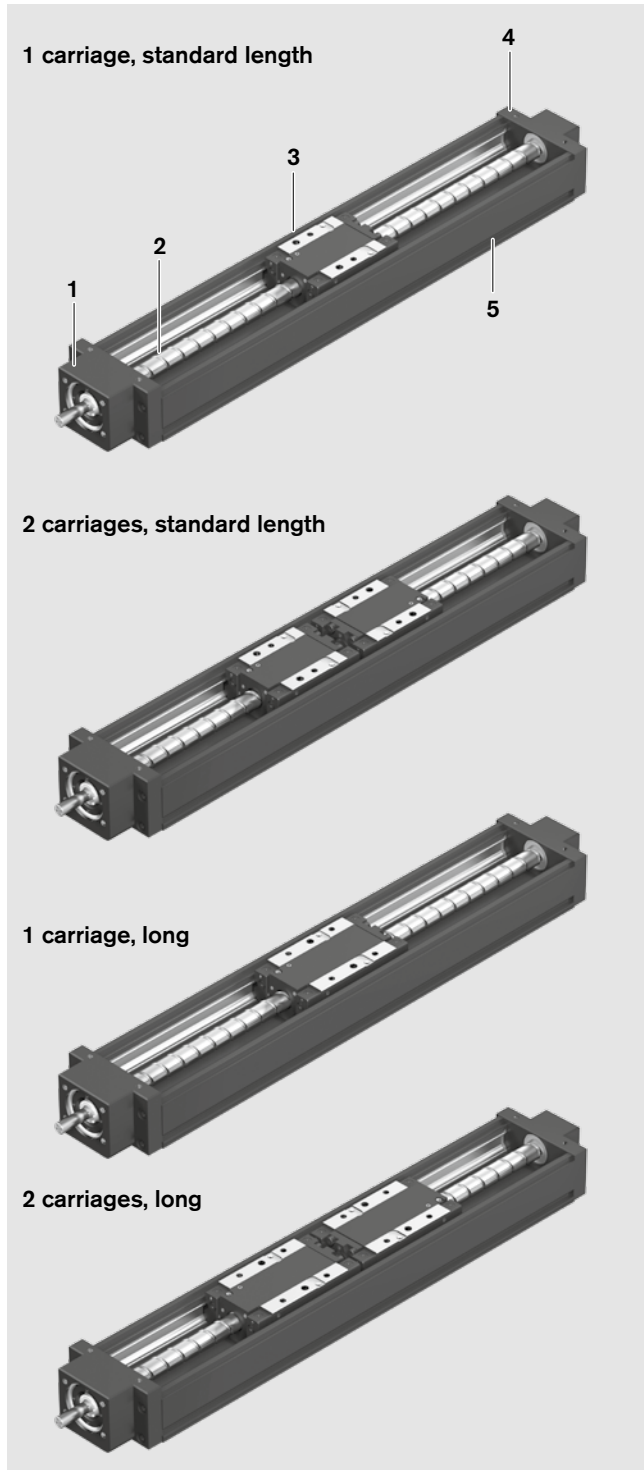

PSK with cover plate

- 6 Cover plate
- 7 One or two carriages, standard length or long
- 8 Carriage plate, aluminum
- 9 Carriage, steel

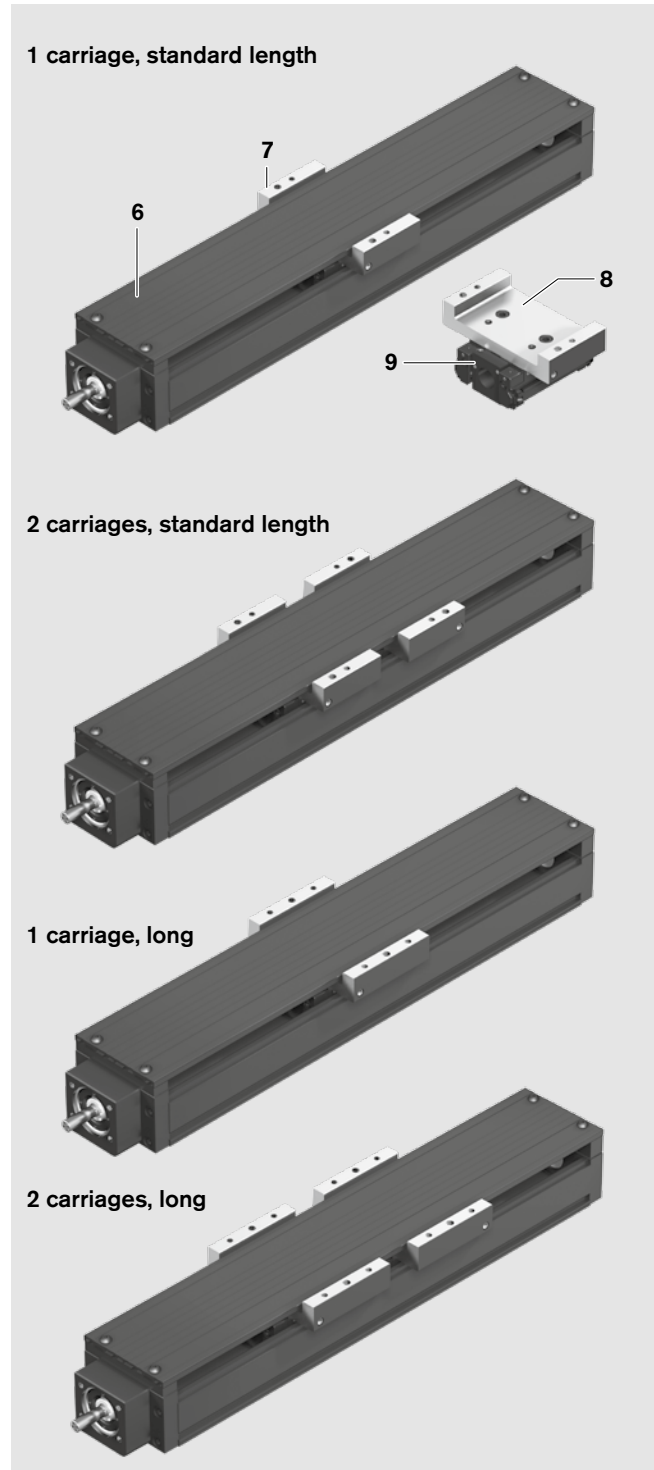

PSK with sealing strip

- 10 Sealing strip, stainless steel
- 11 One carriage, standard length or long
- 12 Carriage plate, aluminum
- 13 Carriage, aluminum

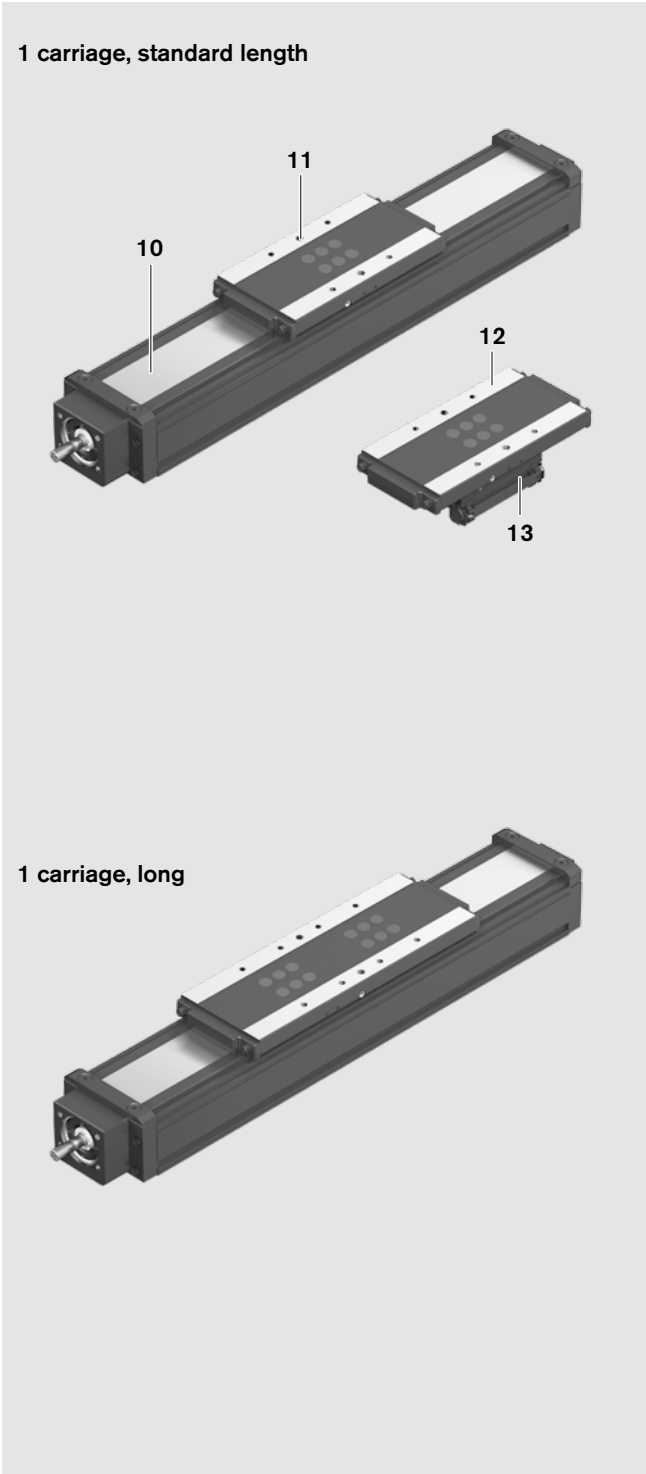

Attachments for all PSK modules

- 14 Switches
- 15 Cable duct
- 16 Switching cam

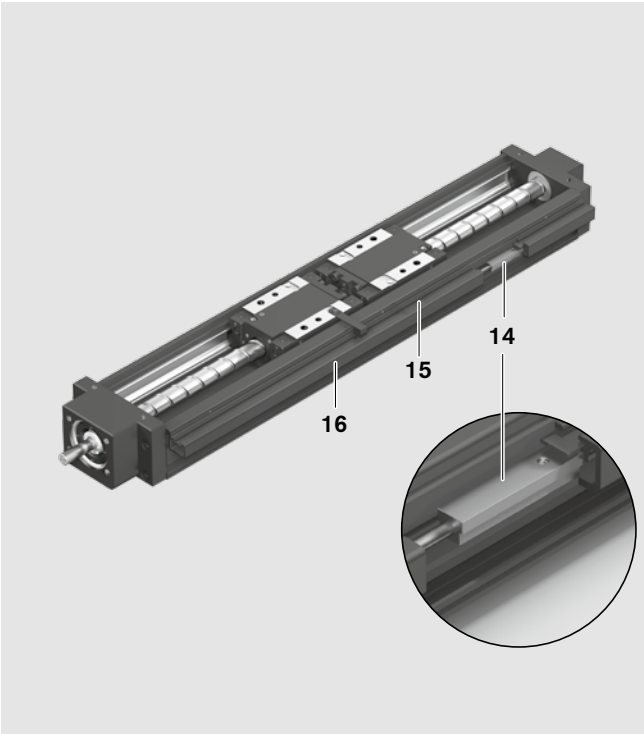

Structural Design

Fixed bearing end block

Version with ball screw journal (A)

- 1 End block with preloaded bearing
- 2 Tapped mounting hole
- 3 Centering feature

Version with integrated motor mount (B)

- 1 End block with integrated motor mount and preloaded bearing
- 2 Tapped mounting hole
- 3 Centering feature
- 4 Flange for motor attachment

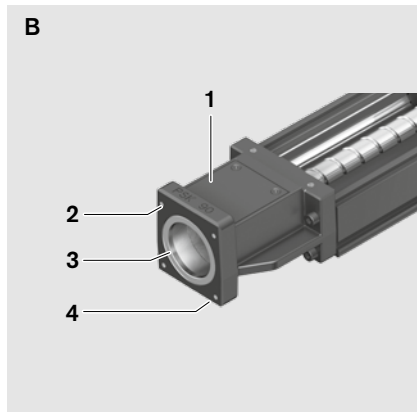
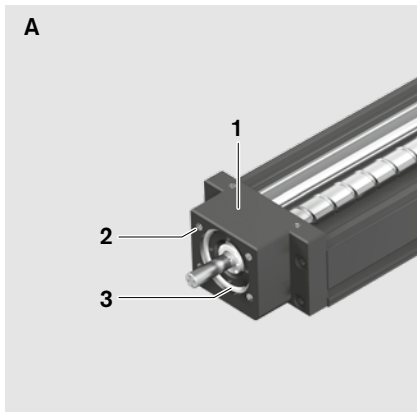

Motor attachment

Motor attachment with motor mount and coupling

A motor can be attached to all Precision Modules by means of a motor mount and coupling.

The motor mount serves to fasten the motor to the Precision Module and acts as a closed housing for the coupling.

The coupling transmits the motor drive torque free of distortive stresses to the Precision Module's ball screw journal.

Fixed bearing end block with integrated motor mount and coupling

- 1 Motor
- 2 Fixed bearing end block with integrated motor mount
- 3 Coupling
- 5 Precision module

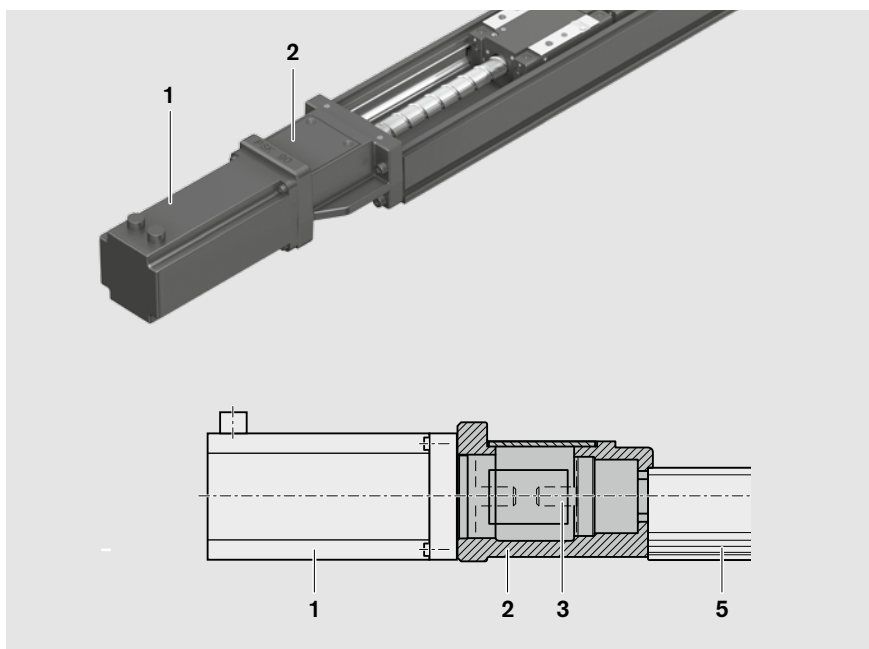

Fixed bearing end block with attached motor mount and coupling

- 1 Motor
- 3 Coupling
- 4 Fixed bearing end block
- 5 Precision module
- 6 Motor mount

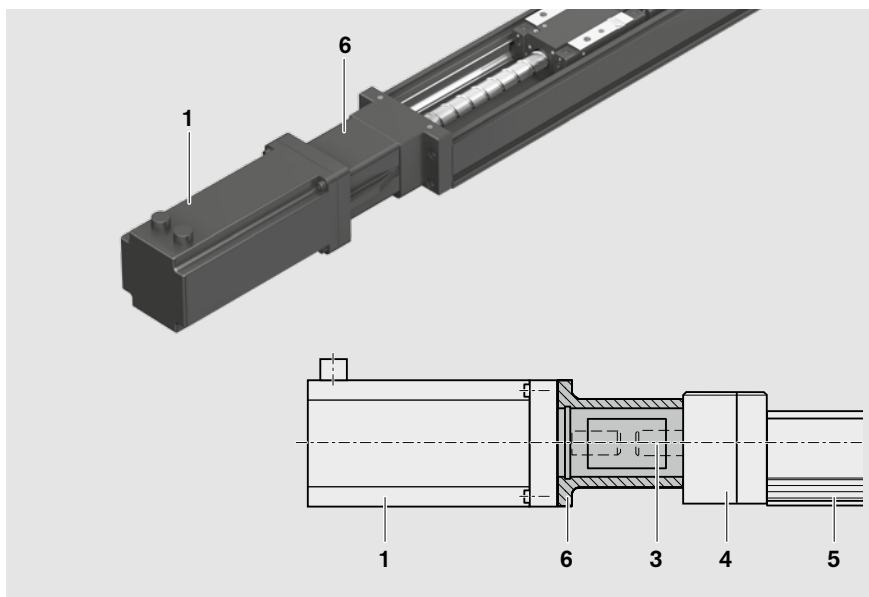

Motor attachment with timing belt side drive

On Precision Modules PSK 60 and PSK 90 the motor (9) can be attached via a side drive with timing belt.

This makes the overall length shorter than when attaching the motor with a motor mount and coupling.

The compact, closed housing protects the belt and secures the motor.

The following gear ratios are available:

$i = 1 : 1$

$i = 1 : 1.5$

The timing belt side drive can be mounted in four different directions:

- top, bottom
- left, right

- 1 Precision module
- 2 End cover
- 3 Cover plate
- 4 Drawn, anodized aluminum profile
- 5 Ball screw journal with support bearing
- 6 Toothed belt
- 7 Pre-tensioning of the toothed belt:
Apply pretensioning force F_{pr} to motor (F_{pr} will be indicated on delivery)
- 8 Belt pulleys
- 9 AC servo motor

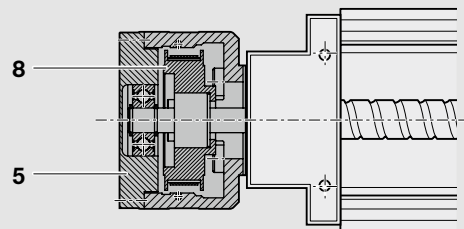
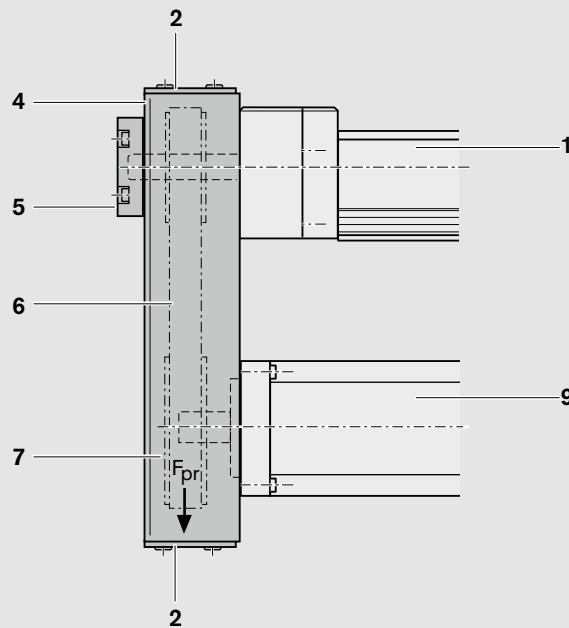
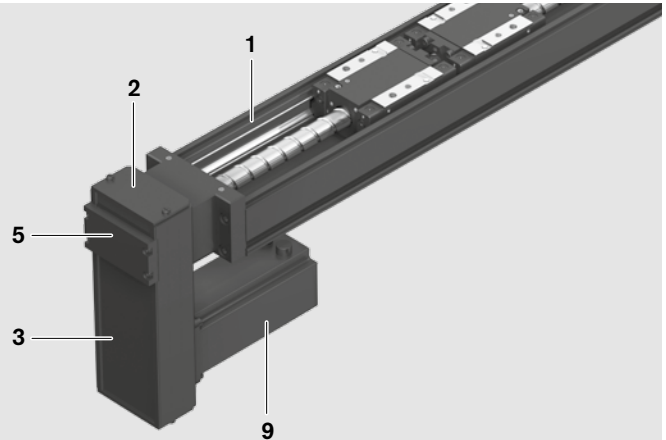

Technical Data

Dynamic characteristics

Precision Module	Type of cover	Carriage (carr.)		Guideway			Ball screw Size $d_0 \times P$	Dynamic load capacity C (N)	Fixed bearing Dynamic load capacity C (N)
		Number		Dynamic load capacity C (N)	Dynamic load moments M_t (Nm) M_L (Nm)				
PSK 40	W/o and w/plate	Standard	1 carr.	3 065	43.1	14.8	6 x 1	900	820
			2 carr.	4 980	70.0	$2.49 \times l_m$	6 x 2	890	820
PSK 50	W/o and w/plate	Standard	1 carr.	7 300	150.0	35	8 x 2.5	2 200	1 600
			2 carr.	11 850	244.0	$5.93 \times l_m$	8 x 2.5	2 200	1 600
	Strip	Standard	1 carr.	7 300	150.0	35	8 x 2.5	2 200	1 600
		Long	1 carr.	11 850	244.0	356	8 x 2.5	2 200	1 600
PSK 60	W/o and w/plate	Standard	1 carr.	7 300	170.0	35	12 x 2	2 240	4 000
			2 carr.	11 850	276.0	$5.93 \times l_m$	12 x 2	2 240	4 000
		Long	1 carr.	9 000	210.0	60	12 x 5	3 800	4 000
			2 carr.	14 620	341.0	$7.31 \times l_m$	12 x 5	3 800	4 000
	Strip	Standard	1 carr.	9 000	210.0	60	12 x 10	2 500	4 000
		Long	1 carr.	14 620	341.0	541	12 x 10	2 500	4 000
PSK 90	W/o and w/plate	Standard	1 carr.	21 300	710.0	150	16 x 5	12 300	13 400
			2 carr.	34 600	1153.0	$17.3 \times l_m$	16 x 5	12 300	13 400
		Long	1 carr.	27 500	910.0	270	16 x 10	9 600	13 400
			2 carr.	44 670	1478.0	$22.34 \times l_m$	16 x 10	9 600	13 400
	Strip	Standard	1 carr.	21 300	710.0	150	16 x 16	6 300	13 400
		Long	1 carr.	34 600	1153.0	1557	16 x 16	6 300	13 400

l_m = center-to-center distance between carriages (mm)

d_0 = screw diameter (mm)

P = screw lead (mm)

carr. = carriage(s) (mm)

m_{ca} = moved mass of system (kg)

General technical data

Precision Module	Planar moment of inertia		Minimum center-to-center distance $l_{m \min}$		Mass of the linear motion system m_s (kg)			
	I_y (cm ⁴)	I_z (cm ⁴)	Standard carr. (mm)	Long carr. (mm)	Without cover, without drive	Without cover, with drive	With cover plate	With sealing strip
PSK 40	0.892	6.65	50	-	$0.0026 \cdot L + m_{ca}$	$0.0028 \cdot L + 0.075 + m_{ca}$	$0.0030 \cdot L + 0.089 + m_{ca}$	-
PSK 50	1.690	13.50	60	-	$0.0035 \cdot L + m_{ca}$	$0.0038 \cdot L + 0.179 + m_{ca}$	$0.0041 \cdot L + 0.204 + m_{ca}$	$0.0042 \cdot L + 0.208 + m_{ca}$
PSK 60	5.380	34.48	60	75	$0.0062 \cdot L + m_{ca}$	$0.0069 \cdot L + 0.254 + m_{ca}$	$0.0072 \cdot L + 0.281 + m_{ca}$	$0.0073 \cdot L + 0.272 + m_{ca}$
PSK 90	22.340	145.80	90	110	$0.0125 \cdot L + m_{ca}$	$0.0138 \cdot L + 0.638 + m_{ca}$	$0.0146 \cdot L + 0.726 + m_{ca}$	$0.0147 \cdot L + 0.736 + m_{ca}$

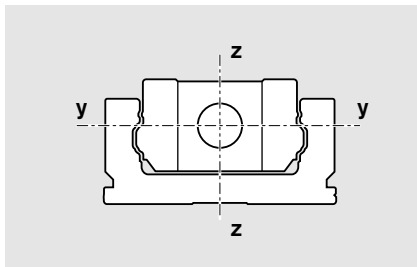

Mass

Mass calculation without motor and switches.

Mass formula:

Mass factor (kg/mm) · length L (mm)
+ mass of all parts of fixed length (kg) +
moved mass of system m_{ca} (kg)

Modulus of elasticity E

$E = 210,000 \text{ N/mm}^2$

Note on dynamic load capacities and moments

Determination of the dynamic load capacities and moments is based on a travel life of 100,000 m.

Often only 50,000 m are actually stipulated.

For comparison: Multiply values **C**, **M_t** and **M_L** from the table by 1.26.

Maximum permissible loads

The maximum permissible forces ($F_{y \max}$, $F_{z \max}$) and moments ($M_{x \max}$, $M_{y \max}$, $M_{z \max}$) are equal to half the dynamic characteristics (**C**, **M_t**, **M_L**).

Suitable loads (recommended values)

With respect to the desired service life, loads up to about 20% of the characteristic dynamic values (**C**, **M_t**, **M_L**) have proved acceptable.

At the same time, the following may not be exceeded:

- maximum permissible loads
- permissible drive torque
- permissible travel speed

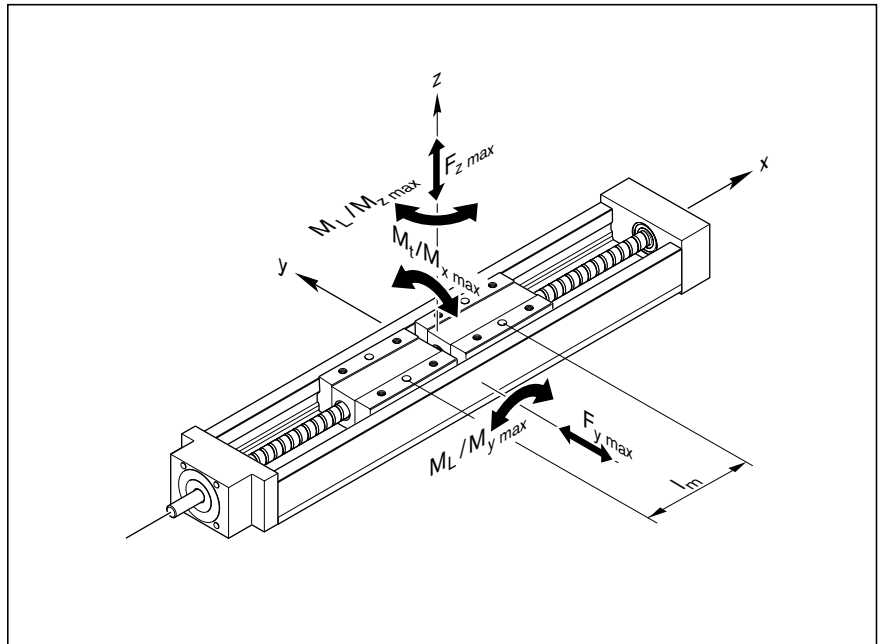

l_m = center-to-center distance between carriages (mm)

Moved mass of system m_{ca}

Precision Module	Carriage	Moved mass of system m_{ca} (kg)						
		Without cover, without drive		Without cover, with drive		With cover plate		With sealing strip
		1 carr.	2 carr.	1 carr.	2 carr.	1 carr.	2 carr.	
PSK 40	Standard	0.08	0.17	0.09	0.18	0.14	0.28	-
PSK 50	Standard	0.20	0.40	0.22	0.42	0.29	0.56	0.20
	Long	-	-	-	-	-	-	0.37
PSK 60	Standard	0.25	0.49	0.27	0.52	0.38	0.73	0.33
	Long	0.34	0.69	0.37	0.71	0.51	1.00	0.58
PSK 90	Standard	0.77	1.54	0.85	1.62	1.09	2.10	0.80
	Long	1.04	2.08	1.11	2.15	1.43	2.79	1.40

carr. = carriage(s) (mm)

Technical Data

Maximum permissible drive torque for mechanical system M_{mech}

The values shown for M_{mech} are applicable under the following conditions:

- Horizontal operation
- Ball screw journal without keyway
- No radial load on ball screw shaft

Consider the rated torque of the coupling used!

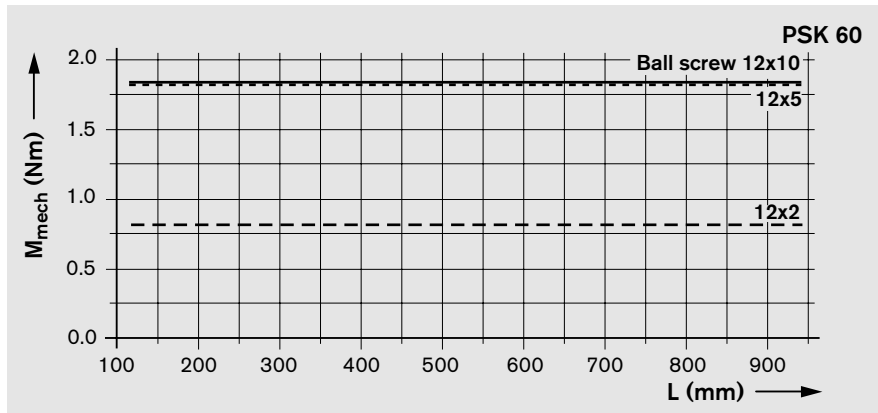
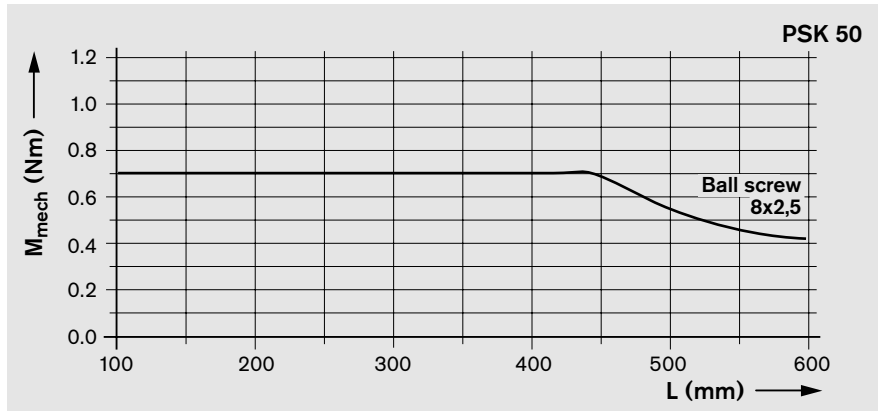
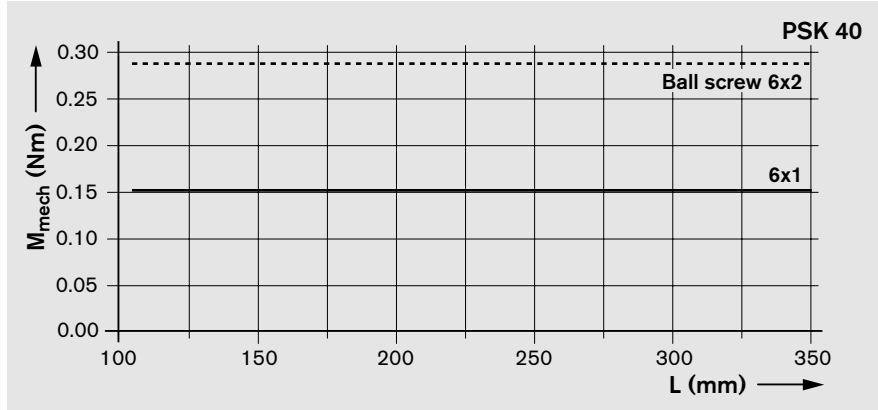

Ball screw journal with keyway

For PSK 90:

If a keyway is used, when comparing the chart against the table, the lower of the two values will always apply!

Precision Module	M_{mech} (Nm)
PSK 90	3.2

- M_{mech} = maximum permissible drive torque for mechanical system (N)
- L = PSK length (mm)
- Ball screw = ball screw size: $d_0 \times P$
- d_0 = screw diameter (mm)
- P = lead (mm)

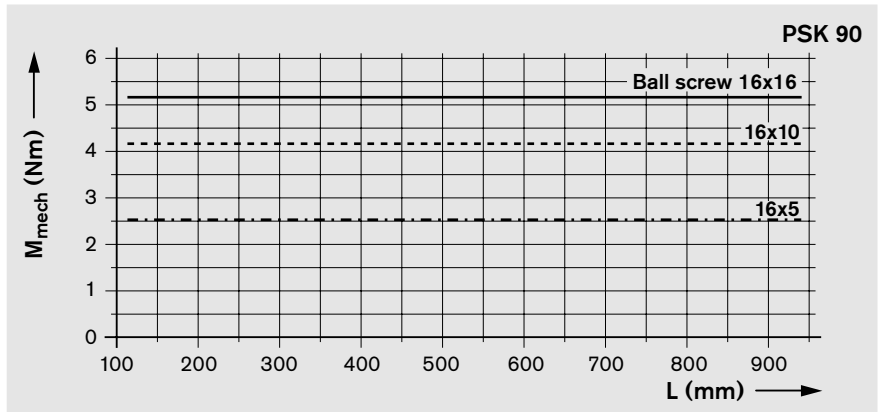

Maximum permissible linear speed of mechanical system v_{mech}

Consider the motor speed!

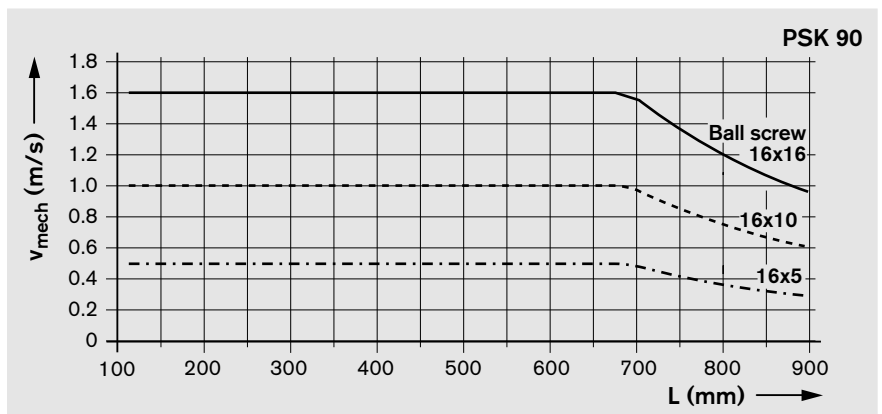
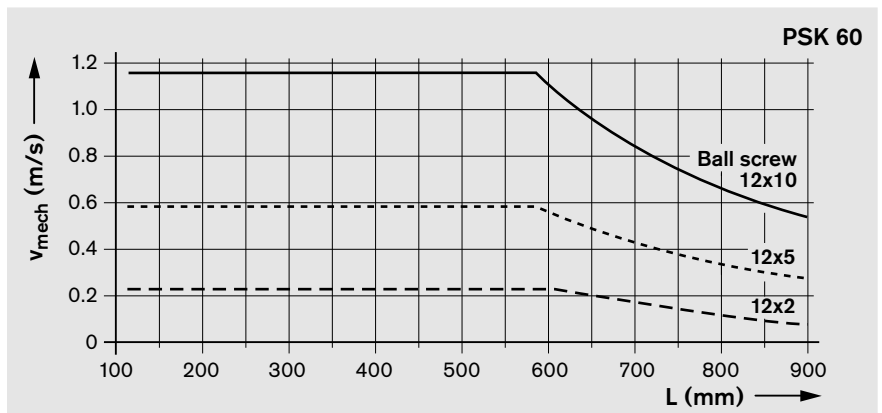
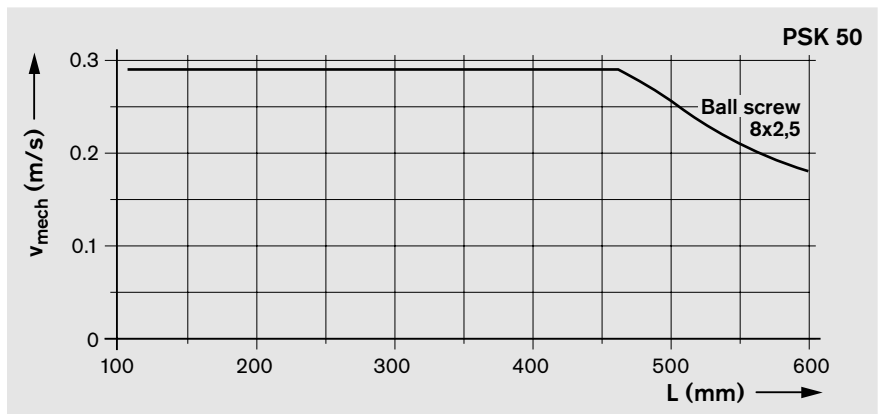
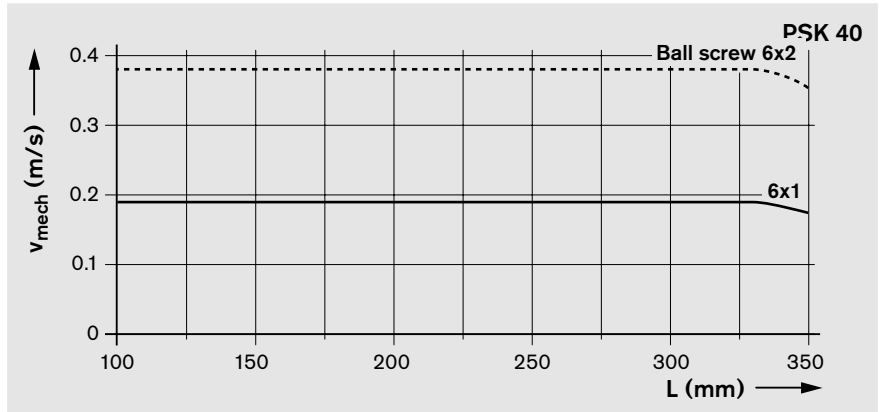

- v_{mech} = maximum permissible linear speed of mechanical system (m/s)
- L = PSK length (mm)
- Ball screw = ball screw size: $d_0 \times P$
- d_0 = screw diameter (mm)
- P = lead (mm)

Technical Data

Drive data of timing belt side drive, fixed bearing end for motor attachment via timing belt side drive

Motor type		MSM 030B / MSM 030C / MSK 030C					MSM 040B / MSK 040C				
Frictional torque M_{Rsd} (Nm)		0.35					0.4				
Gear ratio		Permissible torque up to length L = ... at			Reduced mass moment of inertia at		Permissible torque up to length L = ... at			Reduced mass moment of inertia at	
			i = 1	i = 1.5	i = 1	i = 1.5		i = 1	i = 1.5	i = 1	i = 1.5
Precision Module	Ball screw size $d_0 \times P$	L (mm)	M_{sd} (Nm)	M_{sd} (Nm)	J_{sd} (10^{-6} kgm ²)	J_{sd} (10^{-6} kgm ²)	L (mm)	M_{sd} (Nm)	M_{sd} (Nm)	J_{sd} (10^{-6} kgm ²)	J_{sd} (10^{-6} kgm ²)
PSK 60	12 x 2	940	0.80	0.50	45.6	17.7	–	–	–	–	–
	12 x 5	940	1.60	1.10	45.6	17.7	–	–	–	–	–
	12 x 10	940	1.60	1.10	45.6	17.7	–	–	–	–	–
PSK 90	16 x 5	940	2.40	1.60	40.0	14.0	940	2.40	1.60	234	98.9
	16 x 10	940	2.50	1.70	40.0	14.0	940	3.90	2.60	234	98.9
	16 x 16	940	2.50	1.70	40.0	14.0	940	4.80	3.20	234	98.9

M_{Rsd} = frictional torque of timing belt side drive at motor journal (Nm)

d_0 = screw diameter (mm)

M_{sd} = maximum permissible drive torque of the timing belt side drive (Nm);

P = screw lead (mm)

consider the maximum torque of the motor M_{max}

J_{sd} = mass moment of inertia of timing belt side drive (kgm²)

i = timing belt side drive reduction

Frictional torque of the linear motion system M_{Rs}

Precision Module	Ball screw size $d_0 \times P$	Frictional torque of the linear motion system M_{Rs} (Nm) for carriage version			
		Without cover or with cover plate 1 carr. or 2 carr.		With sealing strip 1 carr. or 2 carr.	
		Standard	Long	Standard	Long
PSK 40	6 x 1	0.033	–	–	–
	6 x 2	0.034	–	–	–
PSK 50	8 x 2.5	0.10	–	0.10	0.11
PSK 60	12 x 2	0.12	0.12	0.12	0.13
	12 x 5	0.13	0.14	0.14	0.15
	12 x 10	0.15	0.16	0.16	0.18
PSK 90	16 x 5	0.30	0.31	0.30	0.31
	16 x 10	0.30	0.33	0.32	0.35
	16 x 16	0.31	0.37	0.34	0.39

carr. = carriage(s) (mm)

d_0 = screw diameter (mm)

P = screw lead (mm)

Mass moment of inertia of the linear motion system J_s referred to the drive journal

$$J_s = (k_{J_{\text{fix}}} + k_{J_{\text{var}}} \cdot L) \cdot 10^{-6}$$

- J_s = mass moment of inertia of linear motion system (without external load) (kgm²)
- $k_{J_{\text{fix}}}$ = constant for fixed-length portion of mass moment of inertia (10⁶ kgm²)
- $k_{J_{\text{m}}}$ = constant for mass-specific portion of mass moment of inertia (10⁶ kgm²)
- $k_{J_{\text{var}}}$ = constant for variable-length portion of mass moment of inertia (10⁹ kgm)
- L = length (mm)

Precision Module	Ball screw size $d_0 \times P$	Carriage	$k_{J_{\text{fix}}}$					$k_{J_{\text{var}}}$	$k_{J_{\text{m}}}$
			Without cover		Cover plate		Sealing strip 1 carr.		
			1 carr.	2 carr.	1 carr.	2 carr.			
PSK 40	6 x 1	Standard	0.115	0.117	0.116	0.120	–	0.002	0.025
	6 x 2	Standard	0.122	0.131	0.127	0.141	–	0.002	0.101
PSK 50	8 x 2,5	Standard	0.533	0.565	0.544	0.587	0.530	0.004	0.158
		Long	–	–	–	–	0.557		
PSK 60	12 x 2	Standard	0.999	1.024	1.010	1.045	1.005	0.013	0.101
		Long	1.009	1.043	1.023	1.073	1.030		
	12 x 5	Standard	1.130	1.289	1.200	1.422	1.168	0.011	0.633
		Long	1.194	1.409	1.282	1.593	1.327		
	12 x 10	Standard	1.643	2.277	1.922	2.808	1.795	0.011	2.533
		Long	1.897	2.758	2.251	3.492	2.492		
PSK 90	16 x 5	Standard	4.216	4.703	4.368	5.007	4.184	0.031	0.633
		Long	4.216	4.703	4.368	5.007	4.184		
	16 x 10	Standard	5.831	7.781	6.439	8.997	5.704	0.031	2.533
		Long	6.489	9.124	7.300	10.745	7.224		
	16 x 16	Standard	9.213	14.207	10.770	17.319	8.889	0.034	6.485
		Long	10.899	17.643	12.974	21.793	12.780		

Coupling data

Precision Module	for motor attachment	Coupling data		
		Rated torque M_{cN} (Nm)	Mass moment of inertia J_c (10 ⁻⁶ kgm ²)	Weight m_c (kg)
PSK 40	MSM 020B	0.70	0.12	0.015
PSK 50	MSM 020B	1.90	2.10	0.040
	MSM 030B	3.70	7.00	0.075
	MSK 030C	3.70	7.00	0.075
	VRDM 368	3.70	7.00	0.075
PSK 60	MSM 030B	3.70	7.00	0.075
	MSK 030C	1.90	2.10	0.040
	VRDM 368	5.50	20.00	0.040
PSK 90	MSM 030C	10.00	35.00	0.170
	MSM 040B	9.00	60.00	0.260
	MSK 030C	10.00	35.00	0.170
	MSK 040C	9.00	60.00	0.260
	VRDM 3910	9.00	60.00	0.260
	VRDM 397	9.00	60.00	0.260

Technical Data, Calculations

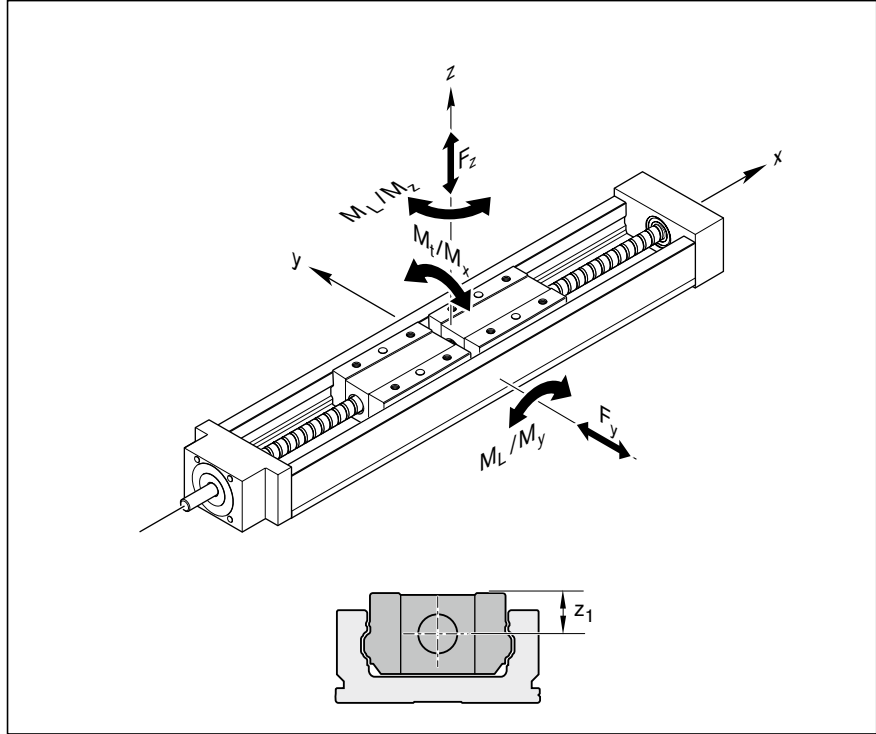

Combined equivalent load on bearing of the linear guide

$$(1) \quad F_{\text{comb}} = |F_y| + |F_z| + C \cdot \frac{|M_x|}{M_t} + C \cdot \frac{|M_y|}{M_L} + C \cdot \frac{|M_z|}{M_L}$$

- F_{comb} = combined equivalent load on bearing (N)
- F_y = force in y-direction (N)
- F_z = force in z-direction (N)
- M_x = torsional moment (about the x-axis) (Nm)
- M_y = torsional moment (about the y-axis) (Nm)
- M_z = torsional moment (about the z-axis) (Nm)
- C = dynamic load capacity (N)
- M_t = dynamic torsional moment load capacity (Nm)
- M_L = dynamic longitudinal moment load capacity (Nm)

	z_1 (mm)		
	Without cover	Cover plate	Sealing strip
PSK 40	11	23	-
PSK 50	13	27	27
PSK 60	17	32	32
PSK 90	22	44	44

z_1 = distance between guideway centerline and top edge of carriage (mm)

Nominal life

Nominal life of the guideway in meters:

$$(2) \quad L = \left(\frac{C}{F_{\text{comb}}} \right)^3 \cdot 10^5 \text{ m}$$

Nominal life of the guideway in hours:

$$(3) \quad L_h = \frac{L}{3600 \cdot v_m}$$

Frictional torque

Frictional torque for motor attachment via motor mount and coupling:

$$(4) \quad M_R = M_{R_s}$$

Frictional torque for motor attachment via timing belt side drive:

$$(5) \quad M_R = \frac{M_{R_s}}{i} + M_{R_{sd}}$$

Mass moment of inertia

for motor attachment via motor mount and coupling:

$$(6) \quad J_{\text{ex}} = J_s + J_t + J_c$$

for motor attachment via timing belt side drive:

$$(7) \quad J_{\text{ex}} = \frac{J_s + J_t}{i^2} + J_{sd}$$

Translatory mass moment of inertia of external load referred to the drive journal

$$(8) \quad J_t = m_{\text{ex}} \cdot k_{Jm} \cdot 10^{-6}$$

C	= dynamic load capacity	(N)
F _{comb}	= combined equivalent load on bearing	(N)
i	= timing belt side drive reduction	(-)
J _c	= mass moment of inertia, coupling	(kgm ²)
J _{ex}	= mass moment of inertia of mechanical system	(kgm ²)
J _s	= mass moment of inertia of linear motion system (without external load)	(kgm ²)
J _t	= translatory mass moment of inertia of external load referred to the drive journal	(kgm ²)
k _{Jm}	= constant for mass-specific portion of mass moment of inertia	(10 ⁶ m ²)
L	= nominal life	(m)
L _h	= nominal life	(h)
m _{ex}	= moved external load	(kg)
M _R	= frictional torque at motor journal	(Nm)
M _{R_{sd}}	= frictional torque of timing belt side drive	(Nm)
M _{R_s}	= frictional torque of linear motion system	(Nm)
v _m	= average speed	(m/s)

Technical Data, Calculations

Mass moment of inertia of the drive train referred to the motor journal

$$(8) \quad J_{dc} = J_{ex} + J_{br}$$

Mass moment of inertia ratio

$$(9) \quad V = \frac{J_{dc}}{J_m}$$

Application area	V
Handling	≤ 6.0
Machining	≤ 1.5

Total mass moment of inertia referred to the motor journal

$$(10) \quad J_{tot} = J_{dc} + J_m$$

Maximum permissible rotary speed for mechanical system

$$(11) \quad n_{mech} = \frac{v_{mech} \cdot i \cdot 1000 \cdot 60}{P}$$

Condition:
 $n_{mech} < n_{m \max}$

- i = timing belt side drive reduction (–)
- J_{br} = mass moment of inertia, motor brake (kgm²)
- J_{dc} = mass moment of inertia, drive train (kgm²)
- J_{ex} = mass moment of inertia of mechanical system (kgm²)
- J_m = mass moment of inertia, motor (kgm²)
- J_{tot} = total mass moment of inertia (kgm²)
- n_{m max} = maximum permissible rotary speed of motor with controller (min⁻¹)
- n_{mech} = maximum permissible rotary speed of mechanical system (min⁻¹)
- P = screw lead (mm)
- V = ratio of mass moments of inertia of drive train and motor (–)
- v_{mech} = maximum permissible linear speed of mechanical system (m/s)

Calculation example

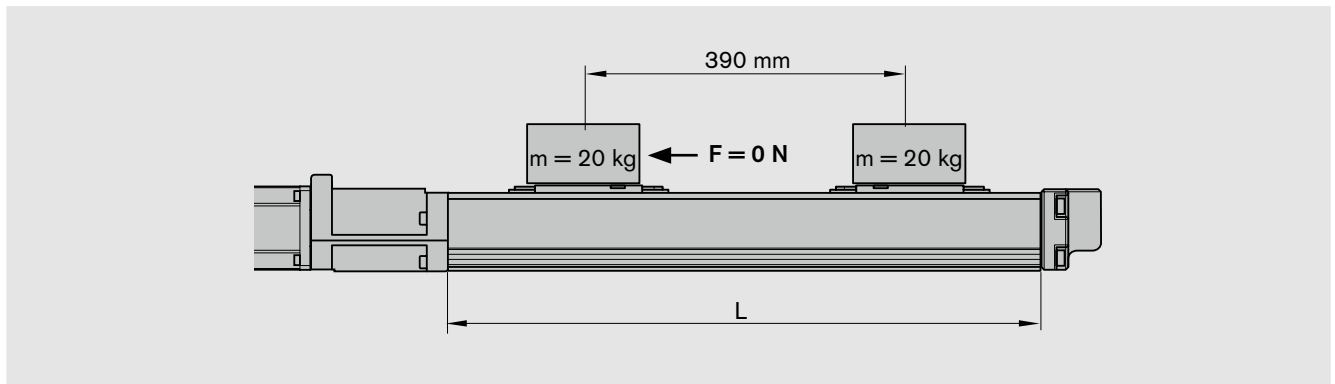

Given data

A mass of 20 kg is to be moved 390 mm at a maximum travel speed of 0.6 m/s.

Module selected based on the technical data and the connection dimensions:

- PSK 90 without cover and with a standard length steel carriage; motor attachment via integrated motor mount and coupling
- Motor type MSK 030C

When sizing the drive, the motor-controller combination must always be considered, as the motor type and performance data (e.g. maximum useful speed and maximum torque) will depend on the controller or control system used.

Estimation of the PSK module length L

$$\begin{aligned} \text{Excess travel} &= 2 \cdot P = 2 \cdot 16 \text{ mm} = 32 \text{ mm} \\ &\text{(in accordance with the formula given in} \\ &\text{“PSK 90 Components and Ordering Data”)} \end{aligned}$$

Selection of ball screw:

As a general rule:
Always choose the lowest lead
(resolution, braking distance, length).

$$\begin{aligned} \text{Permissible ball screws according to the “Permissible travel speed” chart at} \\ v_{\text{mech}} = 0.6 \text{ m/s: } &\text{Ball screw 16x10 and 16x16;} \\ \text{Ball screw selected:} & \\ &\text{Ball screw 16x10 with } v_{\text{mech}} = 1 \text{ m/s} \\ M_{\text{mech}} = 4.1 \text{ Nm with ball screw 16x10} & \\ \text{(according to the chart “Maximum permissible drive torque”)} & \end{aligned}$$

Calculation of PSK length L

$$\begin{aligned} \text{Excess travel} &= 2 \cdot P = 2 \cdot 10 \text{ mm} = 20 \text{ mm} \\ \text{Length L} &= (\text{effective stroke} + 2 \cdot \text{excess travel}) + 100 \text{ mm} = \\ &= (390 \text{ mm} + 2 \cdot 20 \text{ mm}) + 100 \text{ mm} = 530 \text{ mm} \\ \text{Selected:} & \text{Standard length } L = 540 \text{ mm;} \\ & \text{hole spacing in frame: } 70 \text{ mm} / 4 \cdot 100 \text{ mm} / 70 \text{ mm} \end{aligned}$$

Frictional torque M_R

$$\begin{aligned} M_R &= M_{R_s} \\ M_R &= 0.30 \text{ Nm (see “Technical Data”)} \end{aligned}$$

Calculation example (continued)

Mass moment of inertia of mechanical system:

$$\begin{aligned}
 J_{\text{ex}} &= J_{\text{s}} + J_{\text{t}} + J_{\text{c}} \\
 J_{\text{s}} &= (k_{\text{J fix}} + k_{\text{J var}} \cdot L) \\
 &= (5.831 + 0.031 \cdot 540 \text{ mm}) \cdot 10^{-6} \\
 &= 22.57 \cdot 10^{-6} \text{ kgm}^2 \text{ (see "Technical Data")} \\
 J_{\text{t}} &= m_{\text{ex}} \cdot k_{\text{J m}} \cdot 10^{-6} \\
 &= 20 \text{ kg} \cdot 2.533 \cdot 10^{-6} \text{ kgm}^2 \\
 &= 50.66 \cdot 10^{-6} \text{ kgm}^2 \text{ (see "Technical Data")} \\
 J_{\text{c}} &= 60 \cdot 10^{-6} \text{ kgm}^2 \text{ (see "Technical Data")} \\
 J_{\text{ex}} &= (22.57 + 50.66 + 60) \cdot 10^{-6} \text{ kgm}^2 \\
 &= 133.23 \cdot 10^{-6} \text{ kgm}^2 \\
 J_{\text{dc}} &= J_{\text{ex}} + J_{\text{br}} \\
 J_{\text{br}} &= 7.0 \cdot 10^{-6} \text{ kgm}^2 \text{ (see "Motors")} \\
 J_{\text{dc}} &= (133.23 + 7.0) \cdot 10^{-6} \text{ kgm}^2 \\
 &= 140.23 \cdot 10^{-6} \text{ kgm}^2
 \end{aligned}$$

Mass moment of inertia for handling ($V \leq 6$):

$$\begin{aligned}
 V &= \frac{J_{\text{dc}}}{J_{\text{m}}} \leq 6 \\
 V &= \frac{140.23 \cdot 10^{-6} \text{ kgm}^2}{30 \cdot 10^{-6} \text{ kgm}^2} = 4.67 < 6
 \end{aligned}$$

Rotary speed n:

$$n_{\text{mech}} = \frac{v \cdot i \cdot 1000 \cdot 60}{10} = \frac{0.6 \text{ m/s} \cdot 1 \cdot 1000 \cdot 60}{10 \text{ mm}} = 3600 \text{ min}^{-1}$$

Result

Precision Module PSK 90 without cover and with one standard-length steel carriage; Motor MSK 030C, attached via integrated mount and coupling:

Standard length $L = 540 \text{ mm}$;
 Hole spacing in frame: $70 \text{ mm} / 40 \cdot 100 \text{ mm} / 70 \text{ mm}$

Ball screw 16 x 10 with $v_{\text{mech}} = 1 \text{ m/s} > 0.6 \text{ m/s}$
 $M_{\text{mech}} = 4.1 \text{ Nm}$
 Frictional torque $M_{\text{R}} = 0.30 \text{ Nm}$

Motor MSK 030C:

Mass moment of inertia $J_{\text{m}} = 30 \cdot 10^{-6} \text{ kgm}^2$; $V = 4.67 < 6$
 Rotary speed $n_{\text{m max}} = 9000 \text{ min}^{-1} > 3600 \text{ min}^{-1}$
 Torque $M_{\text{max}} = 4.0 \text{ Nm} < 4.1 \text{ Nm}$

For final motor selection, the drive and performance data must be recalculated as specified in the Rexroth catalog "Control Systems, Electrical Accessories, ..."

Accuracy

General note

All accuracy figures apply to the module when screwed down and assume an ideally flat mounting base. The values given do not take account of any shape deviations in the mounting base surface.

Accuracy P_1

Measured at the carriage center

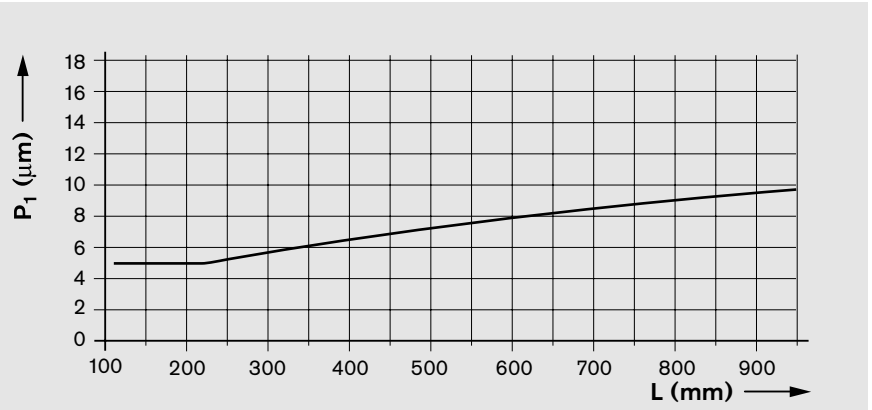
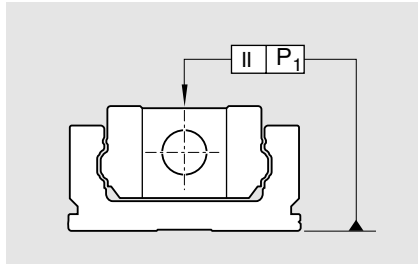

Accuracy P_3

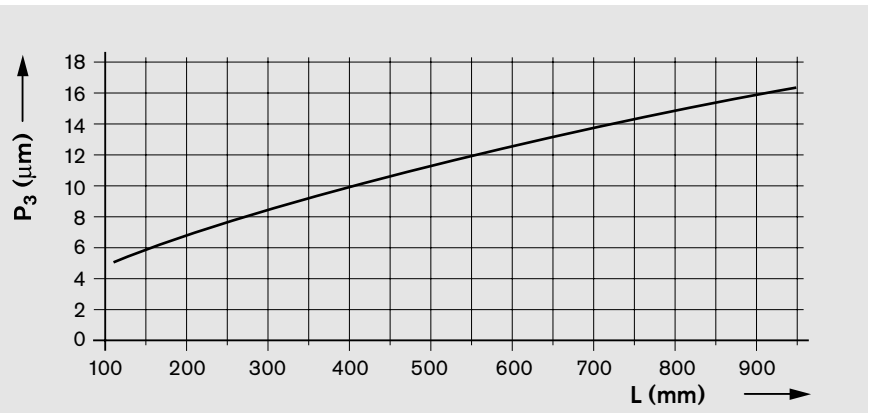
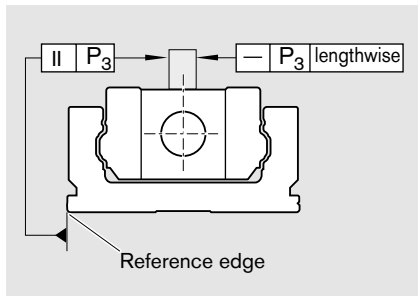

Precision Module PSK 40 Components and Ordering Data

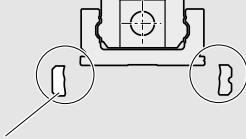
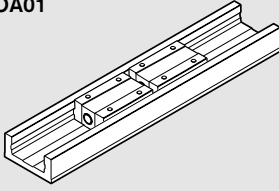
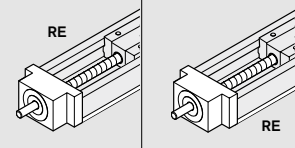
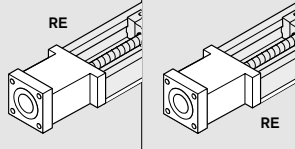
	Part number, length R1465 100 00, mm		Guideway	Drive unit		Carriage version Steel				
				Screw journal	Ball screw size d ₀ x P		Without cover		Cover plate	
	RE left	RE right			Standard	Standard	1 carr.	2 carr.	1 carr.	2 carr.
Without drive	OA01		OA01	without	50		01	02	-	-
					L = 100 mm 10 L = 150 mm 12					
With ball screw, w/o motor mount	OF01	OF02	OF01 OF02	Ø4	01	02	01	02	21	22
					L = 200 mm 14 L = 250 mm 16					
With ball screw and integrated mount	MF10	MF11	MF10 MF11	Ø4	30	31	01	02	21	22
					L = 300 mm 18 L = 350 mm 20					

Ordering example: See "Inquiry/Order" form

 Please check whether the selected combination is a permissible one (load capacities, moments, maximum speeds, motor data, etc.)!

- d₀ = screw diameter (mm)
- P = screw lead (mm)
- carr. = carriage(s)
- L = length

	Motor attachment		Motor		Type of cover		Switches / Cable duct / Socket-plug	Documentation	
	Attachment kit ¹⁾	for motor	with brake	without brake	without	cover plate		Standard report	Measurement report
	00	-	00		00	-	Without switch and cable duct	00	02 Friction moment
	00	-	00		00	01	Switches: - Reed sensor 21-... ³⁾ - Hall sensor 22-... ³⁾	01	03 Lead deviation
	30	NEMA 14-C ²⁾	00		00	01	Cable duct	27	04 Travel accuracy
	31	NEMA 17-C ²⁾	00				Switching cam for PSK: - Without cover or with cover plate	35	05 Positioning accuracy
	32	NEMA 17-D ²⁾	00						
	34	MSM 020B	69	68					

- 1) Attachment kit also available without motor (when ordering: enter "00" for motor).
- 2) Use motors complying with the appropriate NEMA specification. Because of the varying shaft dimensions for NEMA-specification motors, the attachment kit does not include a coupling.
- 3) Mounting side for switches: left (L) or right (R)

Switch mounting arrangements

A mounting duct is required for installation of the switches.

Refer to "Switch mounting arrangements" for more information on switch types and switch mounting.

Switches may only be mounted to one side of the Precision Module (left or right).

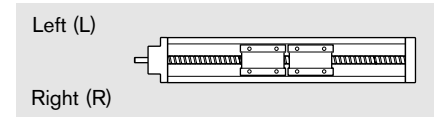

Precision Module PSK 40

Lengths and Hole Spacing

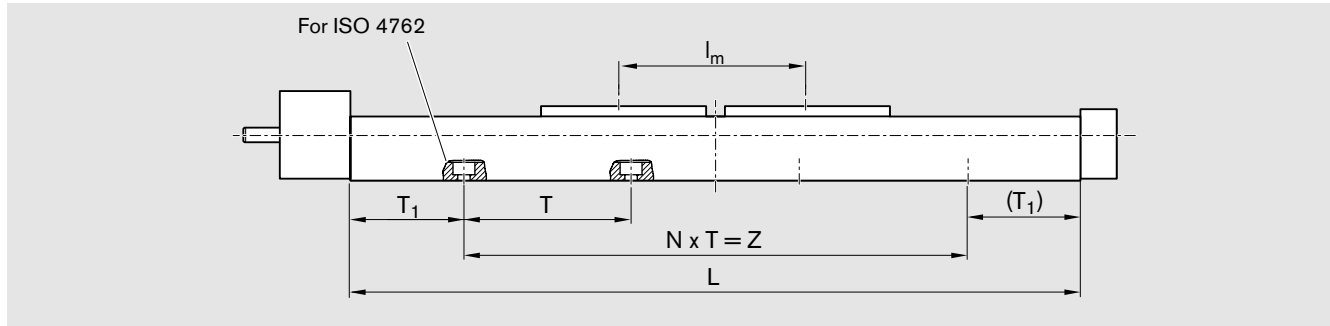

Length L

Type of cover	Number of carriages (carr.)	Carriage version Standard length
Without cover or with cover plate	1 carr.	$L = (\text{stroke} + 2 \cdot \text{excess travel}) + 55 \text{ mm}$
	2 carr.	$L = (\text{stroke} + 2 \cdot \text{excess travel}) + l_m + 55 \text{ mm}$ $l_{m \text{ min}} = 50 \text{ mm}$

l_m = center-to-center distance between carriages (consider $l_{m \text{ min}}$)
 Stroke = maximum travel of carriage center between the outermost switch activation points

In most cases the recommended limit for excess travel (braking path) is:
 Excess travel = $2 \cdot$ screw lead P

Example
 Ball screw 6 x 2
 (Ball screw size = $d_o \times P$):
 Excess travel = $2 \cdot 2 = 4 \text{ mm}$

Standard lengths of frame

Length L (mm)	T (mm)	T_1 (mm)	N	Z (mm)	Mounting holes for ISO 4762 screws
100	60	20	1	60	M3
150	60	15	2	120	
200	60	40	2	120	
250	60	35	3	180	
300	60	30	4	240	
350	60	25	5	300	

Precision Module PSK 40 Dimension Drawings without Cover

All dimensions in mm
Drawings not to scale

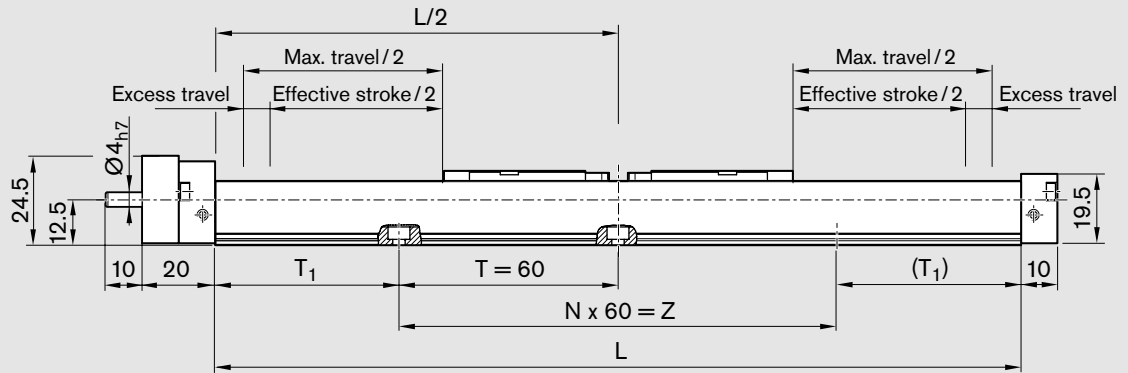

Version:
One or two carriages,
standard length

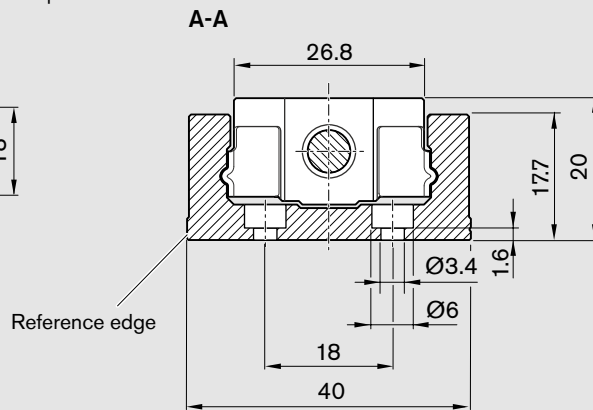
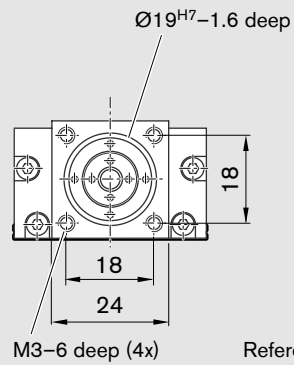
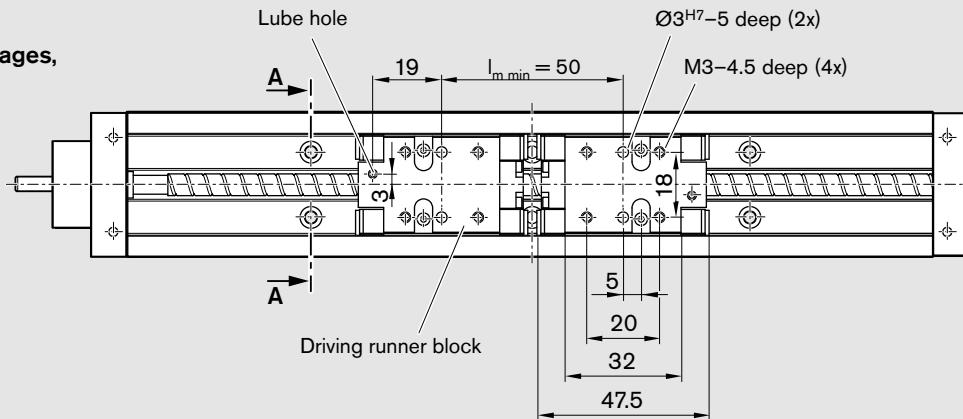

Precision Module PSK 40 Dimension Drawings with Cover Plate

All dimensions in mm
Drawings not to scale

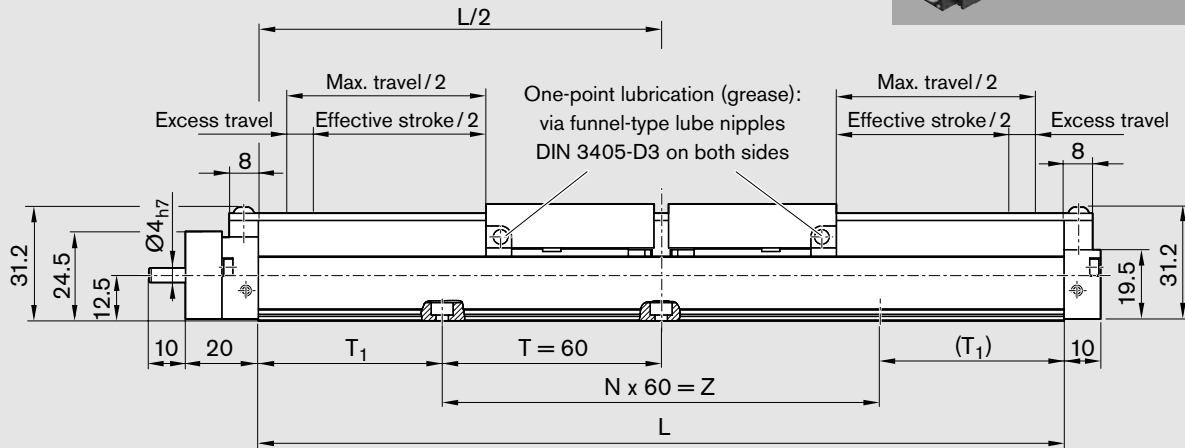
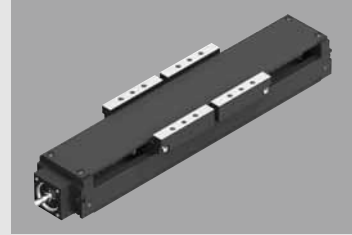

Version:
One or two carriages,
standard length

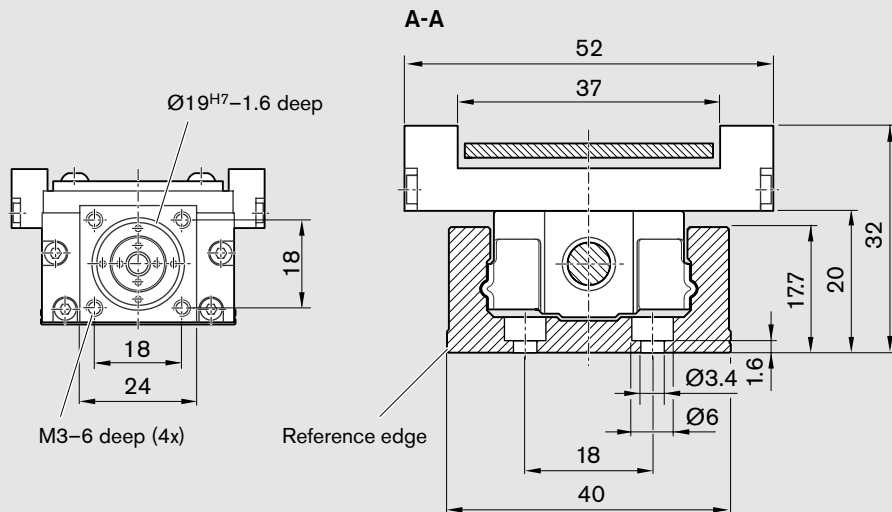
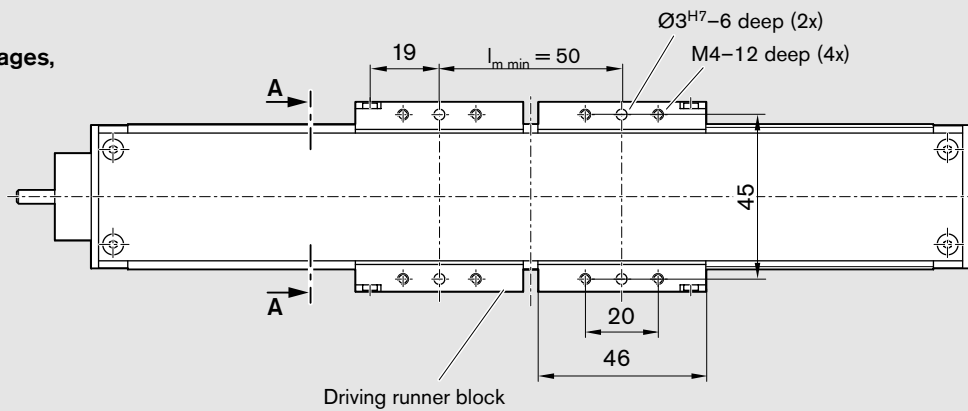

Precision Module PSK 40 Dimension Drawings, Motor Attachment

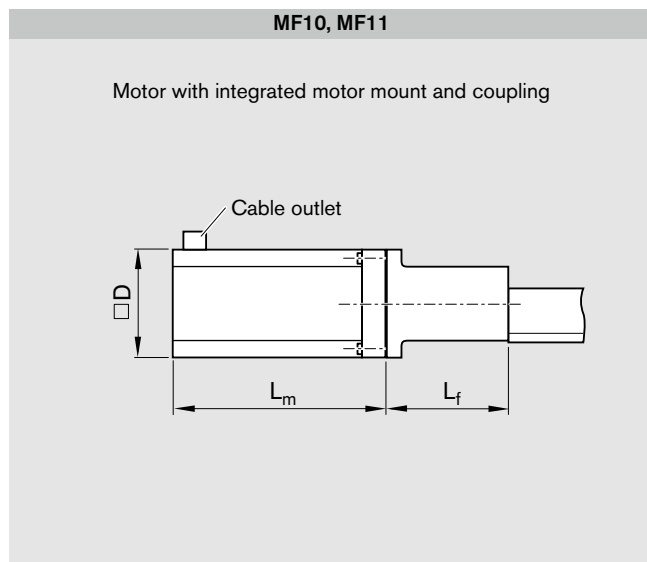
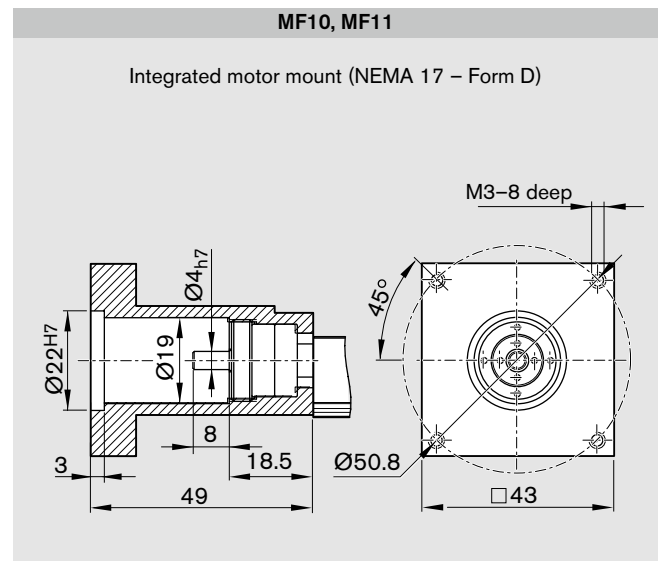
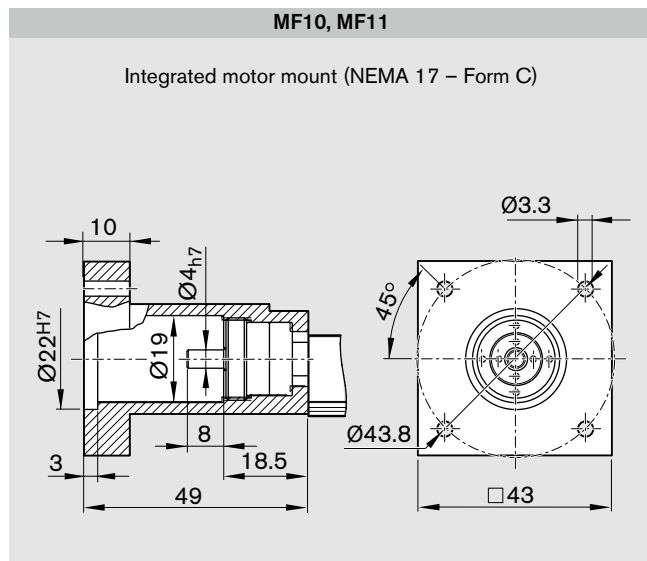
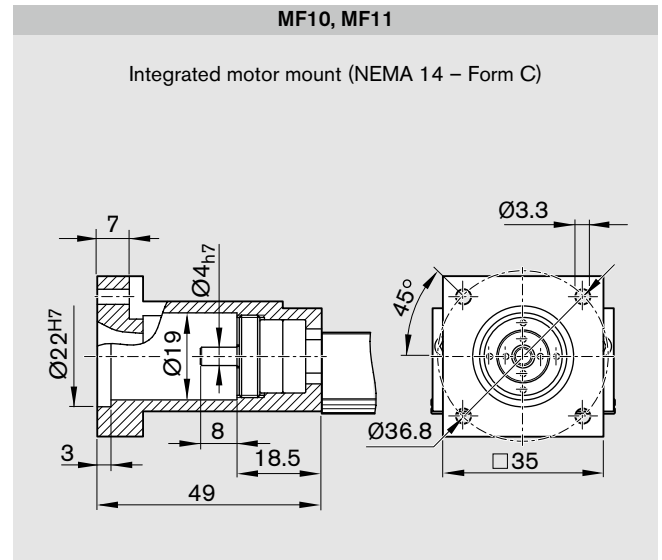
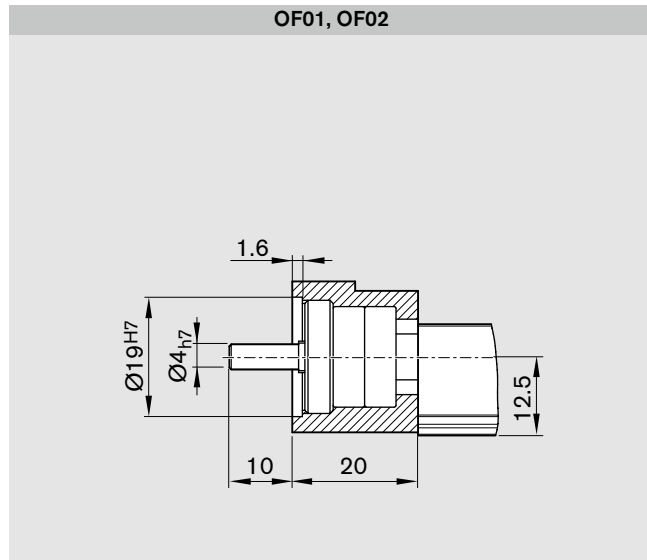

Motor type	Dimensions (mm)		
	D	L _f	L _m
MSM 020B	42	54	without brake 109 with brake 140.5

Drawings not to scale!
For further information and dimensions, see "Motors."

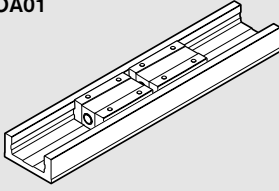
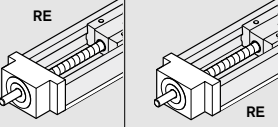
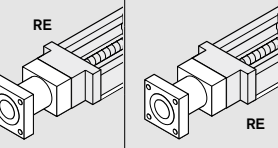
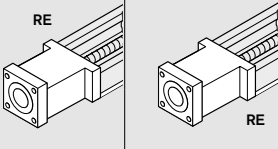

Precision Module PSK 50 Components and Ordering Data

Part number, length R1465 200 00, mm	Reference edge (RE)		Guideway	Drive unit		Carriage version				Aluminum		
	RE left	RE right		Screw journal	Ball screw size $d_0 \times P$	Steel		Steel		Aluminum		
						Without cover	Cover plate	Without cover	Cover plate	Standard	Long	
Version					Standard	Standard	Standard	Standard	Standard	Long	Standard	Long
	RE left	RE right			8 x 2.5	1 carr.	2 carr.	1 carr.	2 carr.	1 carr.	1 carr.	
Without drive	OA01		OA01	without	50	01	02	-	-	-	-	-
												
With ball screw, w/o motor mount	OF01	OF02	OF01 OF02	Ø5	01	01	02	21	22	40	41	
												
With ball screw and motor mount	MF01	MF02	MF01 MF02	Ø5	01	01	02	21	22	40	41	
												
With ball screw and integrated mount	MF10	MF11	MF10 MF11	Ø5	30	01	02	21	22	40	41	
												

Ordering example: See "Inquiry/Order" form

 Please check whether the selected combination is a permissible one (load capacities, moments, maximum speeds, motor data, etc.)!

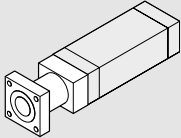
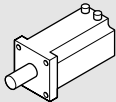
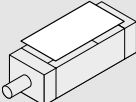
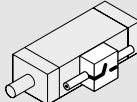
- d_0 = screw diameter (mm)
- P = screw lead (mm)
- carr. = carriage(s)
- L = length

Motor attachment		Motor		Type of cover			Switches / Cable duct / Socket-plug	Documentation	
	Attachment kit ¹⁾	for motor			with brake	without brake			
				with-out	cover plate	strip		Standard report	Measurement report
00	-	00		00	-	-	Without switch and cable duct	00	02 Friction moment
00	-	00		00	01	02	Switches: - Reed sensor - Hall sensor	21-... ³⁾ 22-... ³⁾	03 Lead deviation
01	MSM 030B	71	70				Cable duct	26	04 Travel accuracy
03	MSK 030C	85	84	00	01	02	Switching cam for PSK: - Without cover or with cover plate - With sealing strip	32 34	05 Positioning accuracy
02	VRDM 368	36	35						
31	NEMA 17-D ²⁾	00							
35	NEMA 17-C ²⁾	00		00	01	02			
34	MSM 020B	69	68						

- 1) Attachment kit also available without motor (when ordering: enter "00" for motor).
- 2) Use motors complying with the appropriate NEMA specification. Because of the varying shaft dimensions for NEMA-specification motors, the attachment kit does not include a coupling.
- 3) Mounting side for switches: left (L) or right (R)

Switch mounting arrangements

A mounting duct is required for installation of the switches.

Refer to "Switch mounting arrangements" for more information on switch types and switch mounting.

Switches may only be mounted to one side of the Precision Module (left or right).

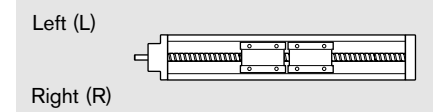

Precision Module PSK 50

Lengths and Hole Spacing

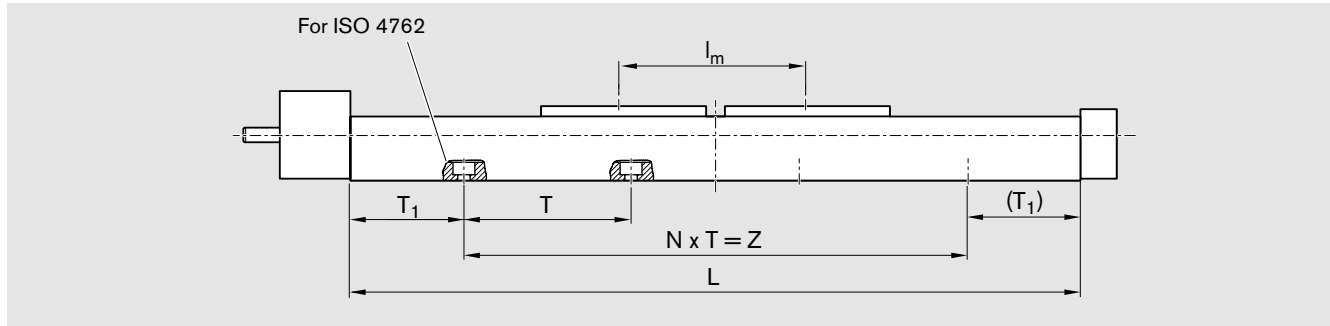

Length L

Type of cover	Number of carriages (carr.)	Carriage version Standard length	Long
Without cover or with cover plate	1 carr.	$L = (\text{stroke} + 2 \cdot \text{excess travel}) + 70 \text{ mm}$	-
	2 carr.	$L = (\text{stroke} + 2 \cdot \text{excess travel}) + l_m + 70 \text{ mm}$ $l_{m \min} = 60 \text{ mm}$	-
With sealing strip	1 carr.	$L = (\text{stroke} + 2 \cdot \text{excess travel}) + 127 \text{ mm}$	$L = (\text{stroke} + 2 \cdot \text{excess travel}) + 187 \text{ mm}$

l_m = center-to-center distance
between carriages (consider
 $l_{m \min}$)

Stroke = maximum travel of carriage
center between the outermost
switch activation points

In most cases the recommended limit
for excess travel (braking path) is:
Excess travel = $2 \cdot \text{screw lead } P$

Example

Ball screw 8 x 2.5

(Ball screw size = $d_o \times P$):

Excess travel = $2 \cdot 2.5 = 5 \text{ mm}$

Standard lengths of frame

Length L (mm)	T (mm)	T_1 (mm)	N	Z (mm)	Mounting holes for ISO 4762 screws
100	80	10	1	80	M4
150	80	35	1	80	
200	80	20	2	160	
250	80	45	2	160	
300	80	30	3	240	
350	80	15	4	320	
400	80	40	4	320	
450	80	25	5	400	
500	80	50	5	400	
550	80	35	6	480	
600	80	20	7	560	

Precision Module PSK 50 Dimension Drawings without Cover

All dimensions in mm
Drawings not to scale

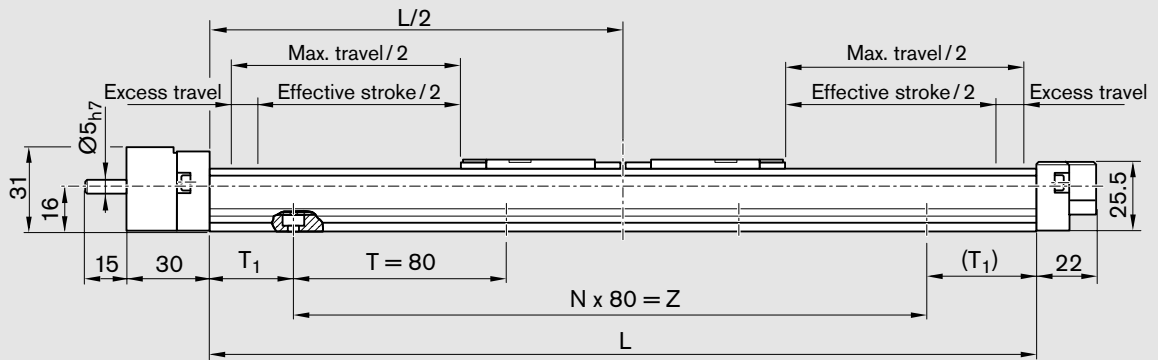
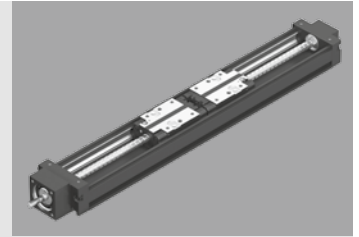

Version:
One or two carriages

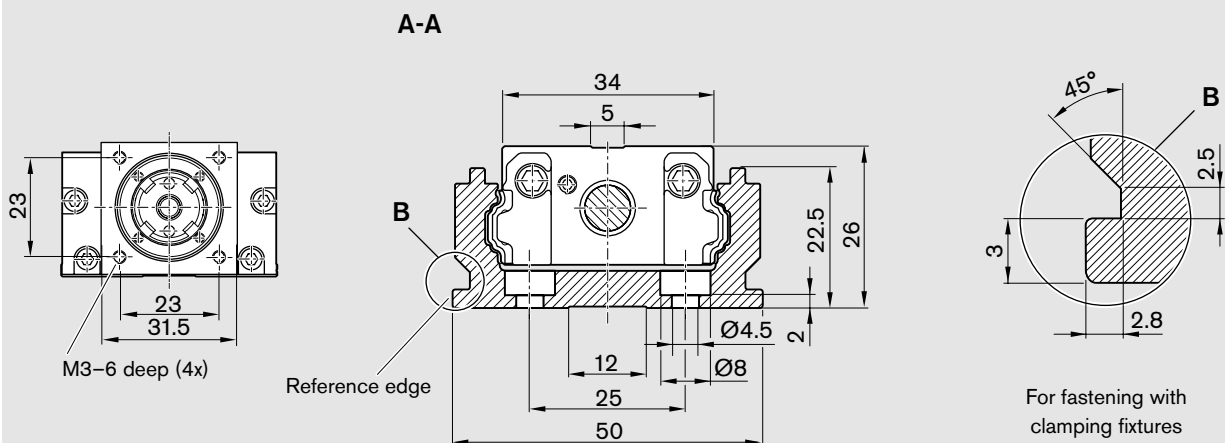
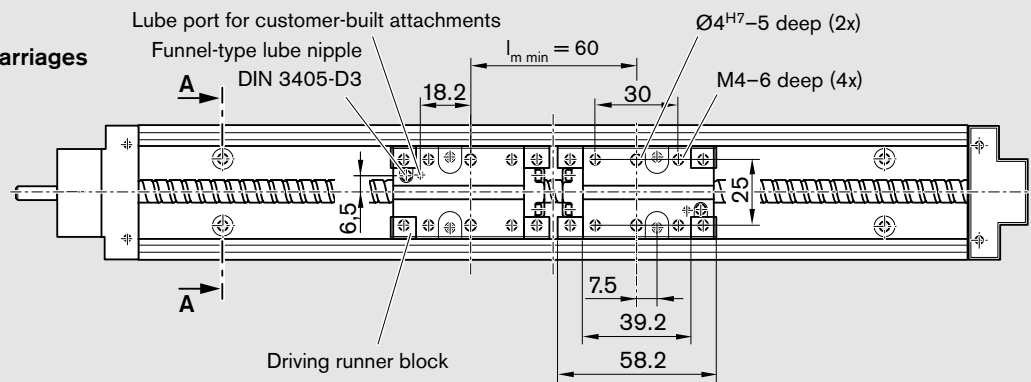

Precision Module PSK 50 Dimension Drawings with Cover Plate

All dimensions in mm
Drawings not to scale

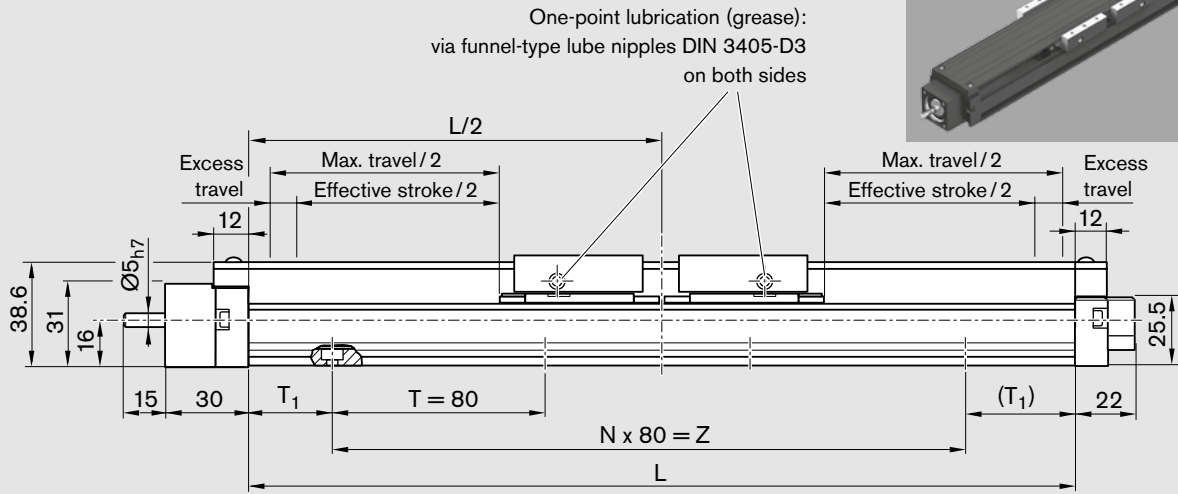
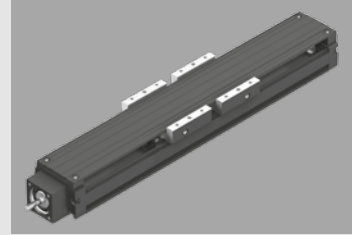

Version:
One or two carriages

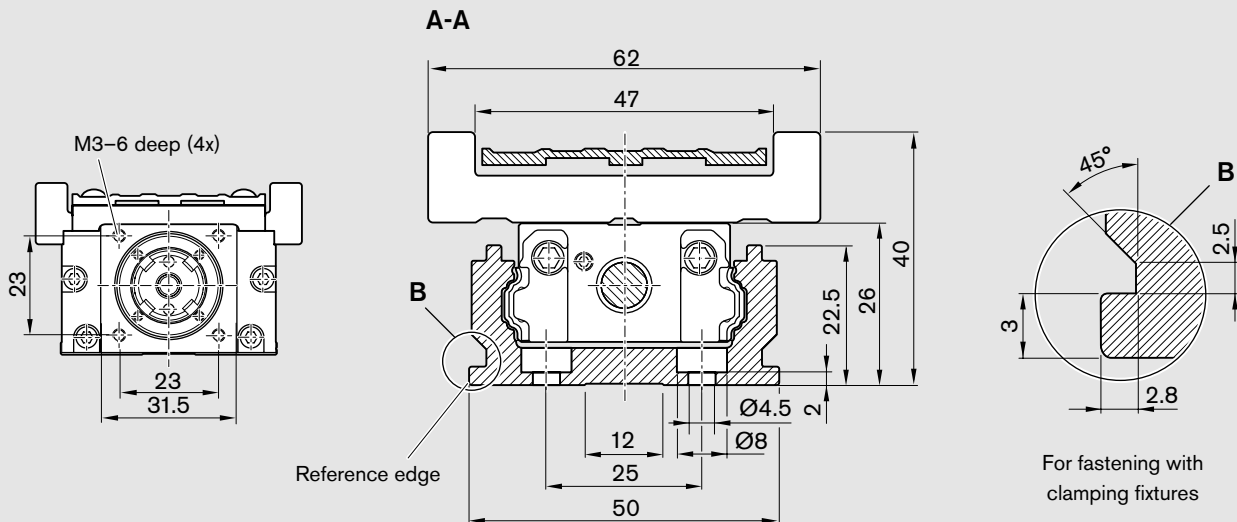
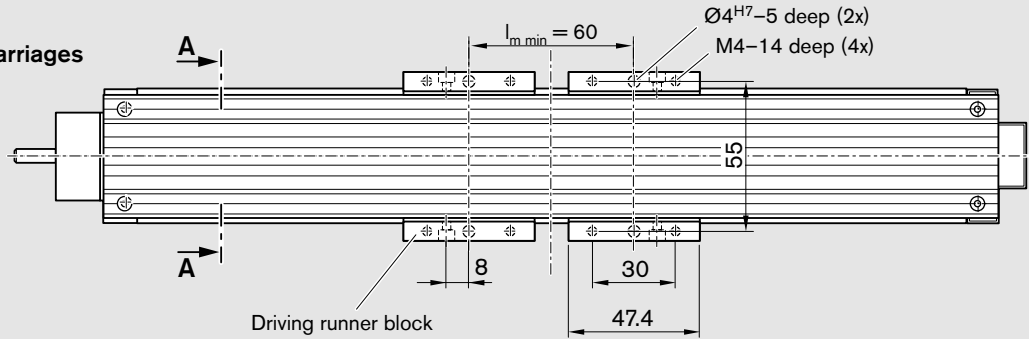

For fastening with
clamping fixtures

Precision Module PSK 50 Dimension Drawings with Sealing Strip

All dimensions in mm
Drawings not to scale

One-point lubrication (grease):
via funnel-type lube nipples DIN 3405-D3
on both sides

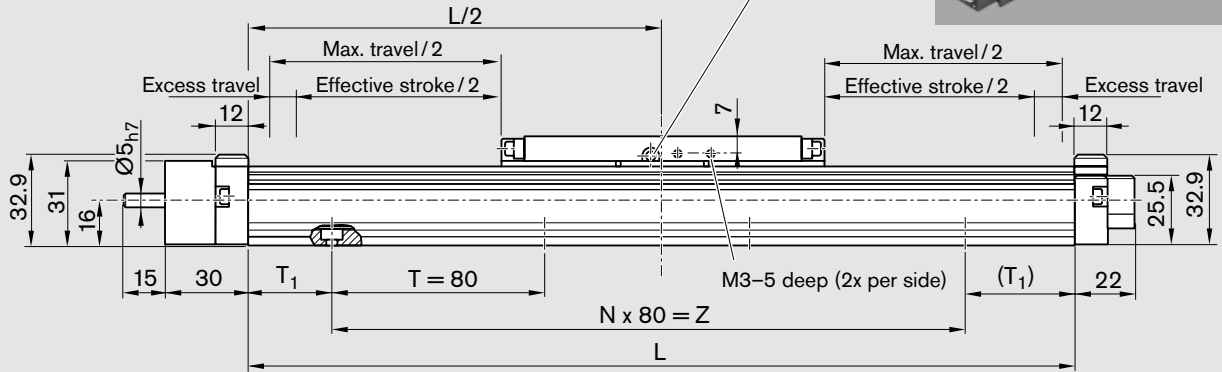
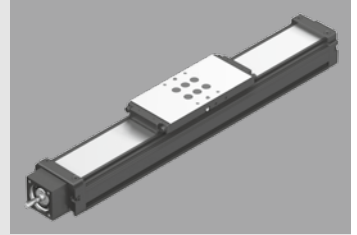

Version:
Carriage, standard length

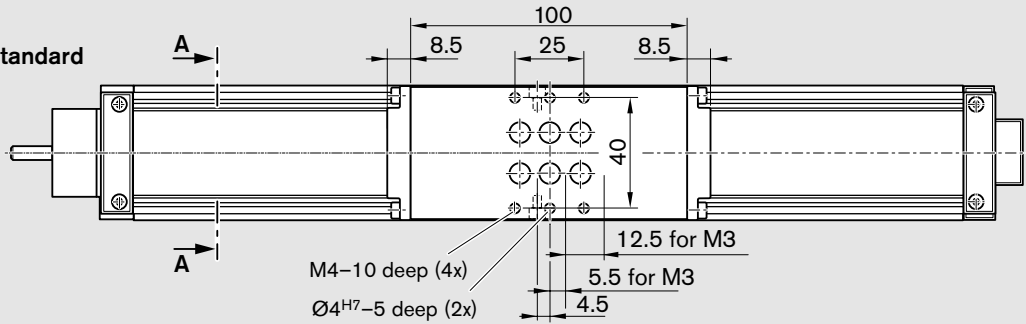

Version:
Carriage, long

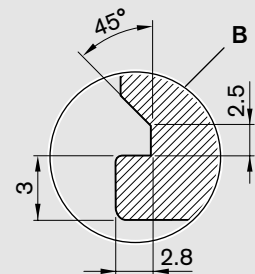
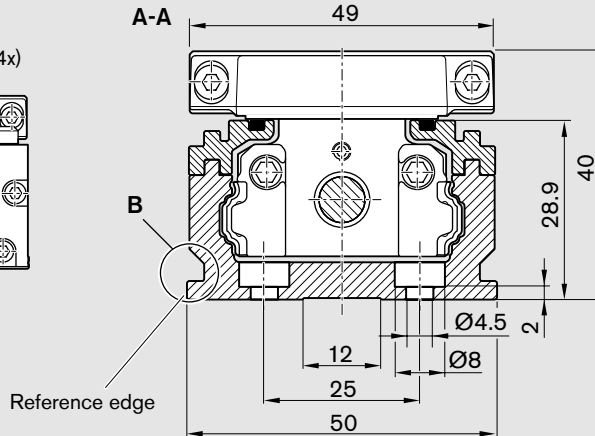
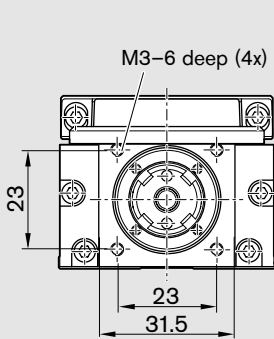
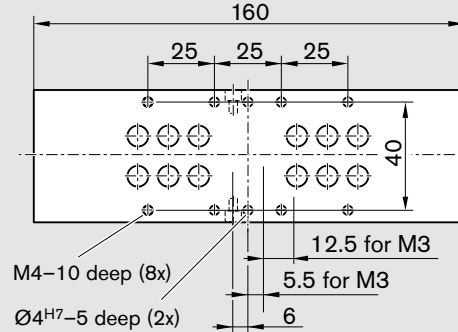

For fastening with
clamping fixtures

Precision Module PSK 50

Dimension Drawings, Motor Attachment

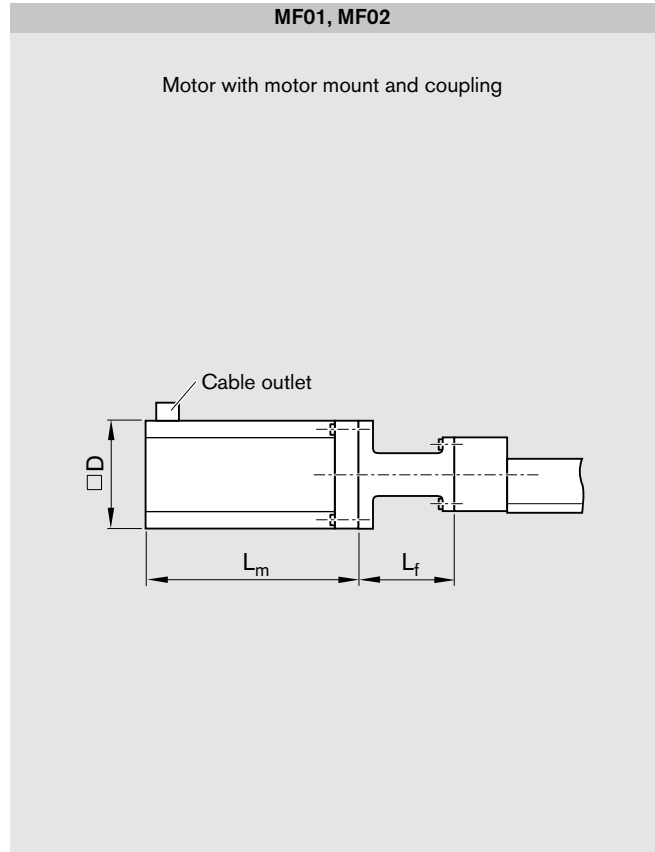
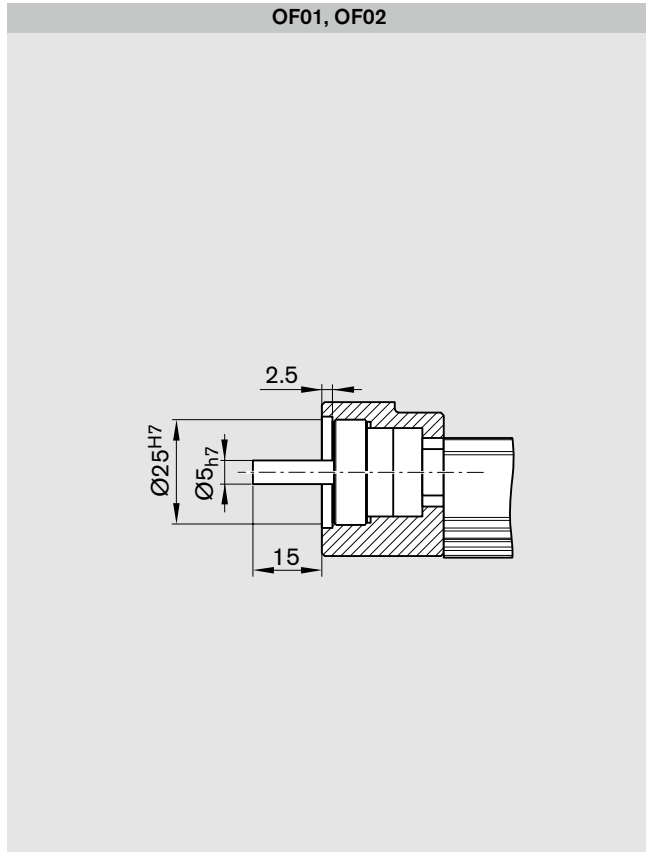

Motor type	Dimensions (mm)			
	D	L_f	without brake	L_m with brake
MSM 030B	60.0	53.0	111	144
MSK 030C	54.0	53.0	188	213
VRDM 368	57.2	53.0	116	157

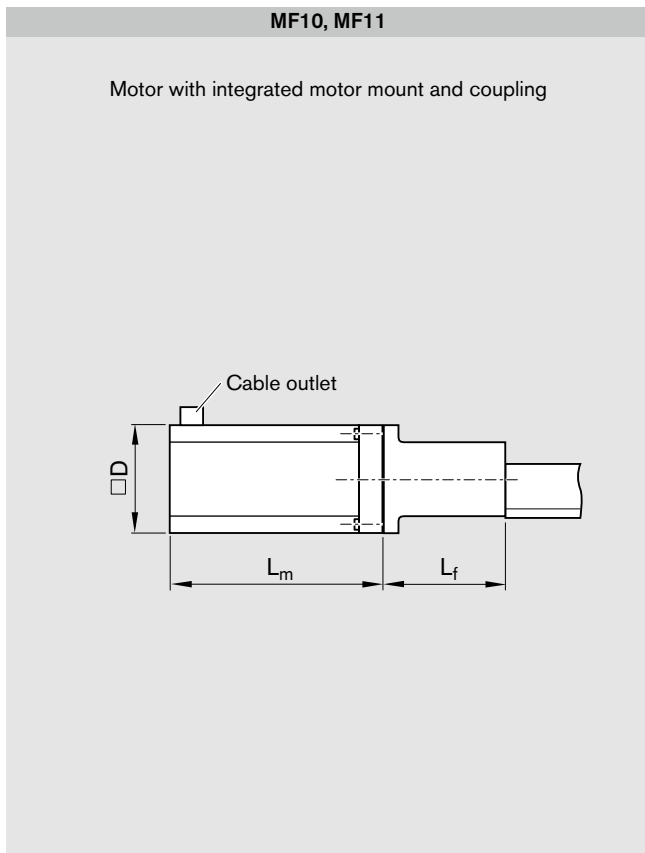
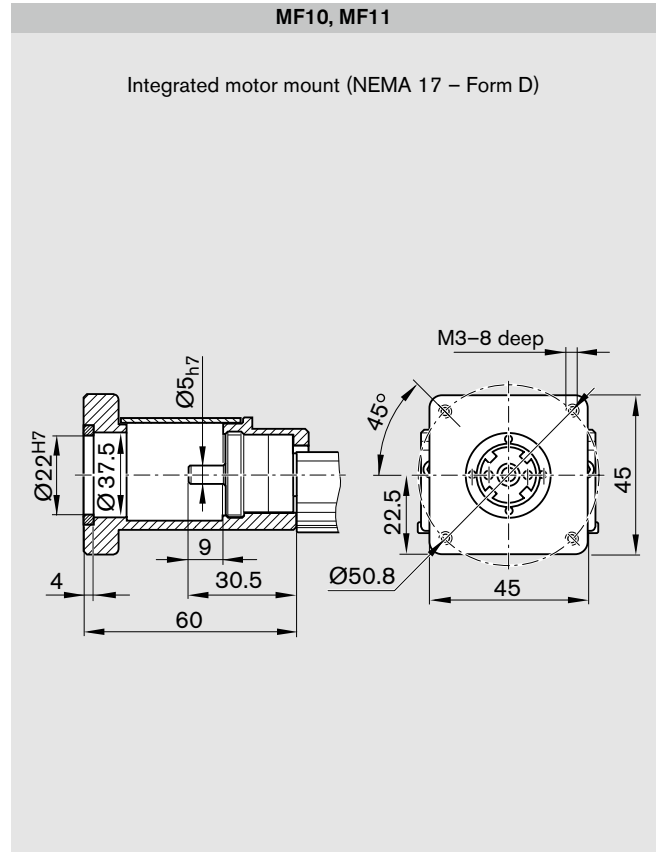
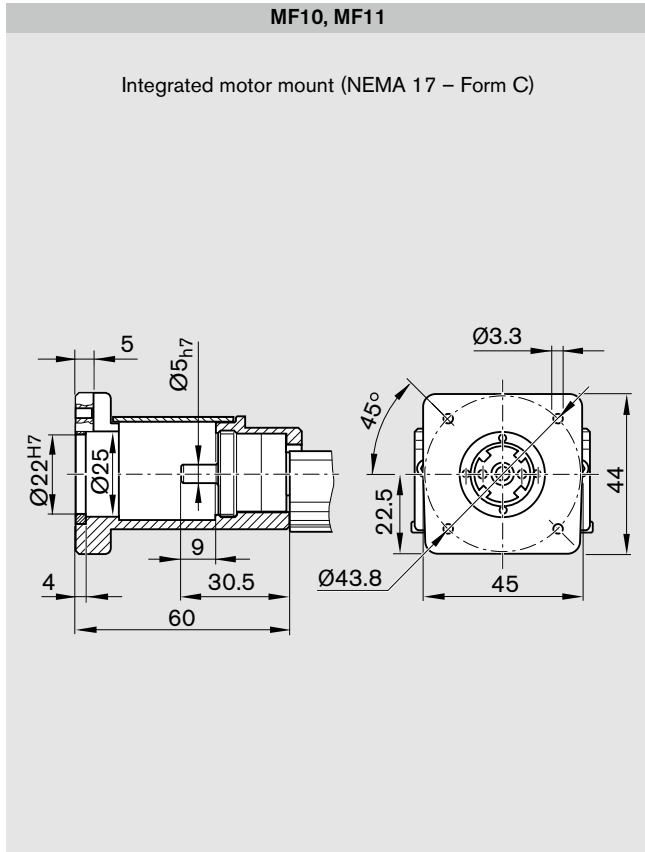

Motor type	Dimensions (mm)		
	D	L _f	L _m
MSM 020B	42	60	without brake 109 with brake 140.5

Drawings not to scale!
For further information and dimensions, see "Motors."

Motor attachment			Motor		Type of cover			Switches / Cable duct / Socket-plug	Documentation		
Gear ratio $i =$	Attach- ment kit ¹⁾	for motor			with- out	cover plate	strip		Standard report	Measure- ment report	
			with brake	without brake							
-	00	-	00		00	-	-				
-	00	-	00		00	01	02				
-	02	VRDM 368	36	35	00	01	02	Without switch and cable duct	00	01	
	03	MSM 030B	71	70				Switches:			
	04	MSM 020B	69	68				- Reed sensor	21-... ³⁾		02
-	31	NEMA 23-D²⁾	00		00	01	02	- Hall sensor	22-... ³⁾		03
	32	MSK 030C	85	84				Cable duct	25		04
$i = 1$	11	MSK 030C	85	84	00	01	02	Switching cam for PSK:		05	
	12							- Without cover or with cover plate	30		05
$i = 1.5$	13	MSM 030B	71	70	00	01	02	- With sealing strip	31		
	14										

- Attachment kit also available without motor (when ordering: enter "00" for motor).
- Use motors complying with the appropriate NEMA specification. Because of the varying shaft dimensions for NEMA-specification motors, the attachment kit does not include a coupling.
- Mounting side for switches: left (L) or right (R)

Switch mounting arrangements

A mounting duct is required for installation of the switches.

Refer to "Switch mounting arrangements" for more information on switch types and switch mounting.

Switches may only be mounted to one side of the Precision Module (left or right).

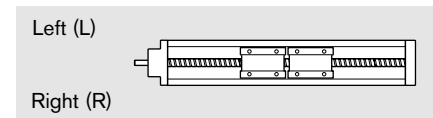

Precision Module PSK 60

Lengths and Hole Spacing

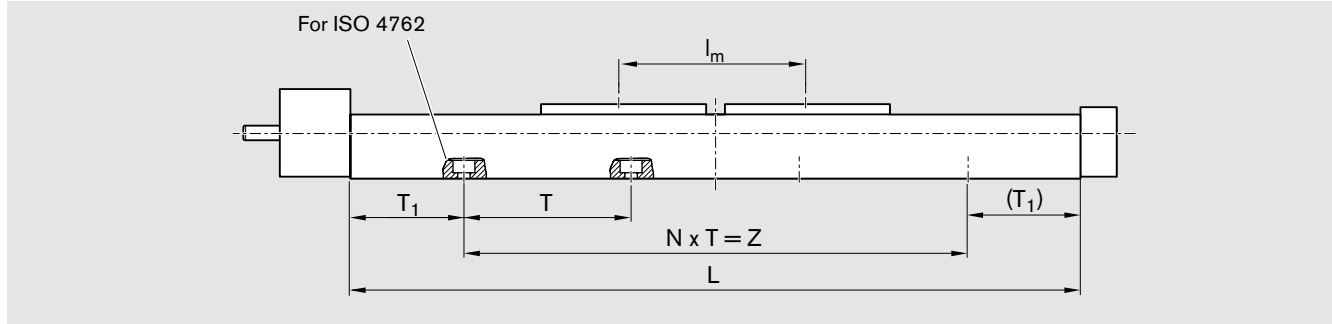

Length L

Type of cover	Number of carriages (carr.)	Carriage version	
		Standard length	Long
Without cover or with cover plate	1 carr.	$L = (\text{stroke} + 2 \cdot \text{excess travel}) + 70 \text{ mm}$	$L = (\text{stroke} + 2 \cdot \text{excess travel}) + 85 \text{ mm}$
	2 carr.	$L = (\text{stroke} + 2 \cdot \text{excess travel}) + l_m + 70 \text{ mm}$ $l_{m \text{ min}} = 60 \text{ mm}$	$L = (\text{stroke} + 2 \cdot \text{excess travel}) + l_m + 85 \text{ mm}$ $l_{m \text{ min}} = 75 \text{ mm}$
With sealing strip	1 carr.	$L = (\text{stroke} + 2 \cdot \text{excess travel}) + 160 \text{ mm}$	$L = (\text{stroke} + 2 \cdot \text{excess travel}) + 215 \text{ mm}$

l_m = center-to-center distance between carriages (consider $l_{m \text{ min}}$)

Stroke = maximum travel of carriage center between the outermost switch activation points

In most cases the recommended limit for excess travel (braking path) is:
Excess travel = $2 \cdot \text{screw lead } P$

Example

Ball screw 12 x 10
(Ball screw size = $d_o \times P$):
Excess travel = $2 \cdot 10 = 20 \text{ mm}$

Standard lengths of frame

Length L (mm)	T (mm)	T_1 (mm)	N	Z (mm)	Mounting holes for ISO 4762 screws
150	100	25	1	100	M5
200	100	50	1	100	
250	100	25	2	200	
300	100	50	2	200	
400	100	50	3	300	
500	100	50	4	400	
600	100	50	5	500	
700	100	50	6	600	
800	100	50	7	700	
900	100	50	8	800	
940	100	20	9	900	

Precision Module PSK 60 Dimension Drawings without Cover

All dimensions in mm
 Drawings not to scale

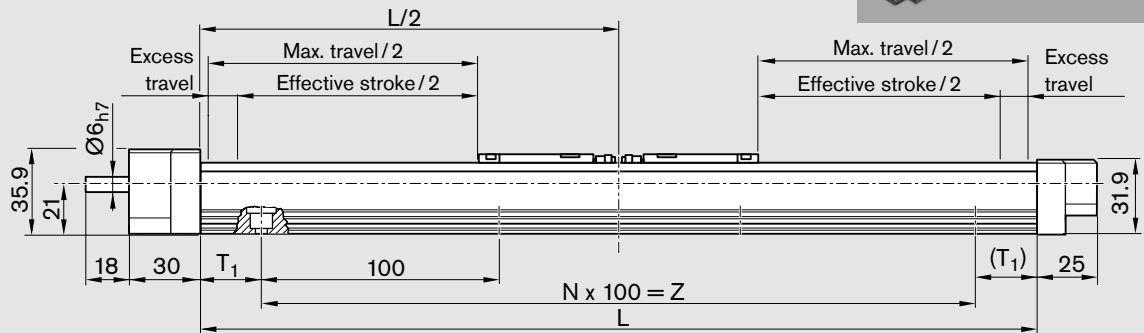
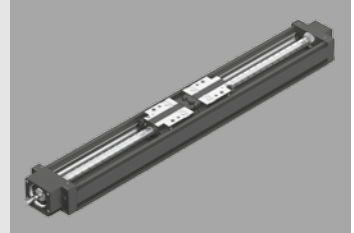

Version:
 One or two carriages,
 standard length

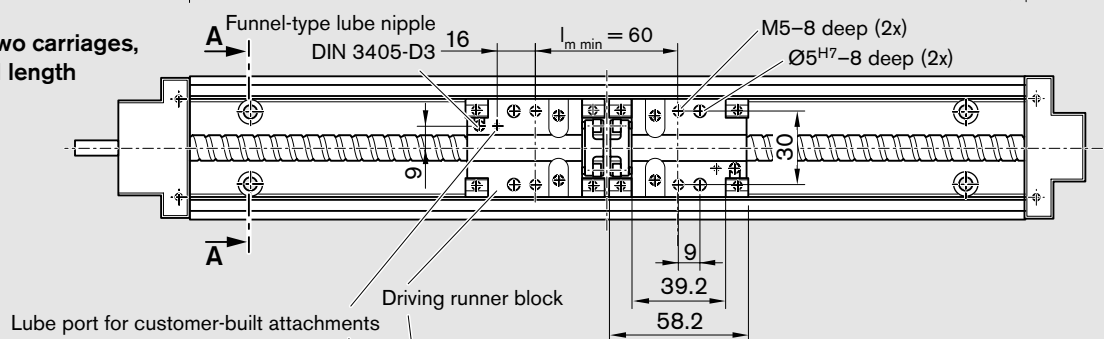

Version:
 One or two carriages,
 long

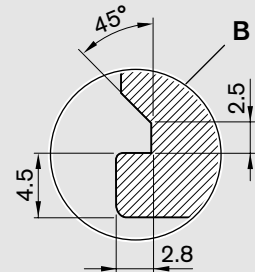
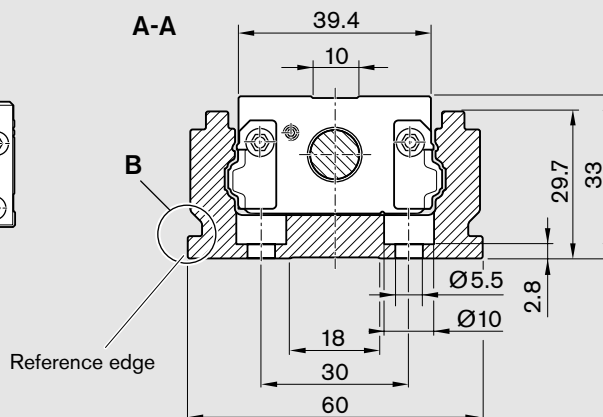
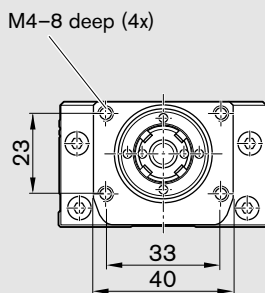
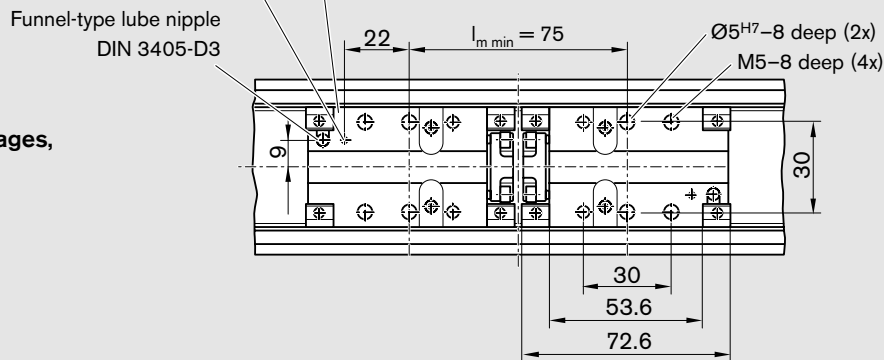

For fastening with
 clamping fixtures

Precision Module PSK 60 Dimension Drawings with Cover Plate

All dimensions in mm
Drawings not to scale

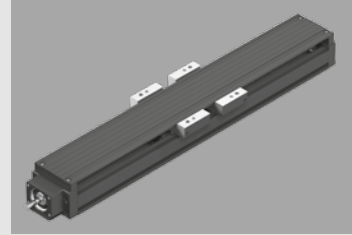

One-point lubrication (grease):
via funnel-type lube nipples DIN 3405-D3
on both sides

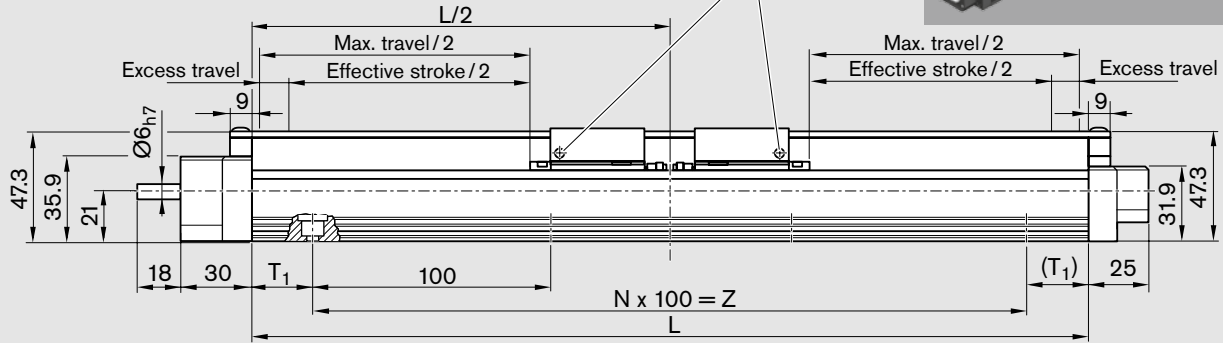

Version:
One or two carriages,
standard length

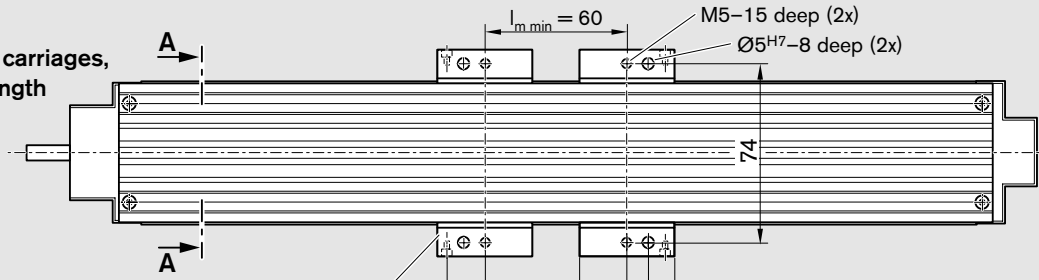

Version:
One or two carriages,
long

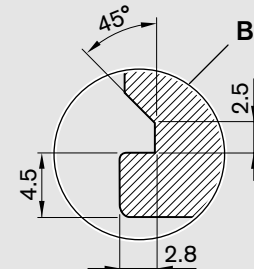
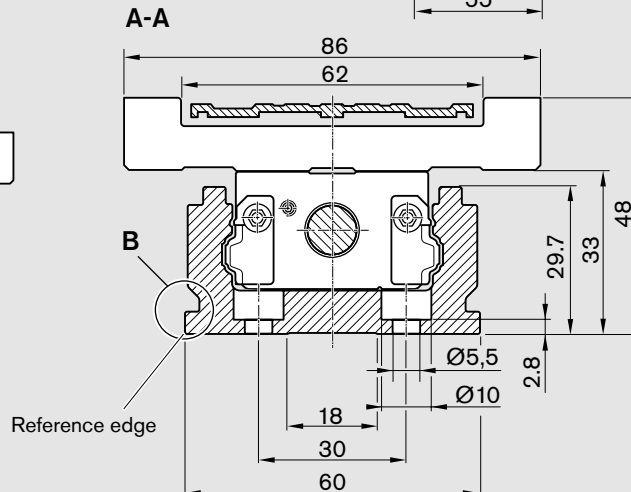
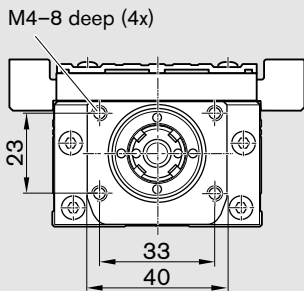
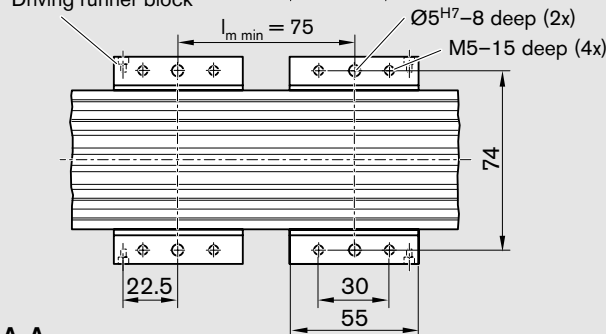

For fastening with
clamping fixtures

Precision Module PSK 60 Dimension Drawings with Sealing Strip

All dimensions in mm
 Drawings not to scale

One-point lubrication (grease):
 via funnel-type lube nipples DIN 3405-D3
 on both sides

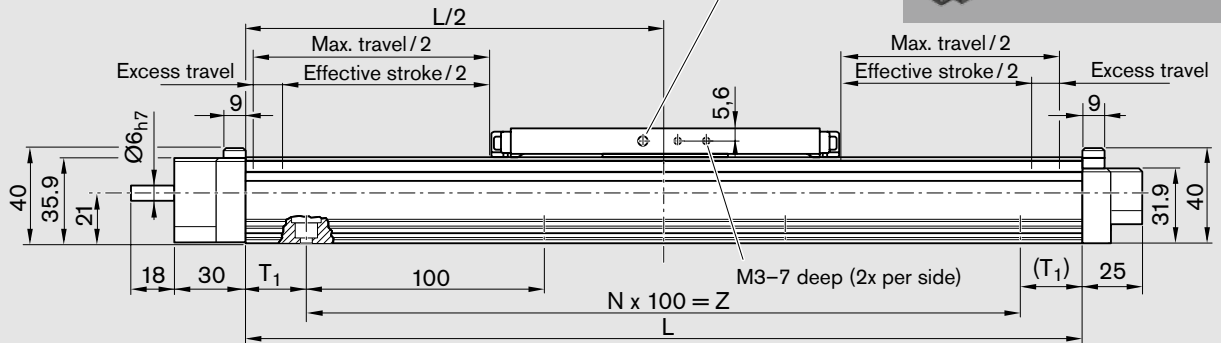
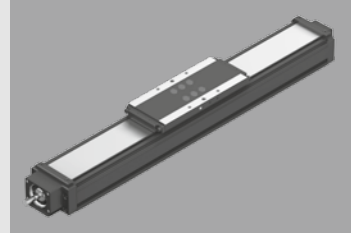

Version:
 Carriage, standard length

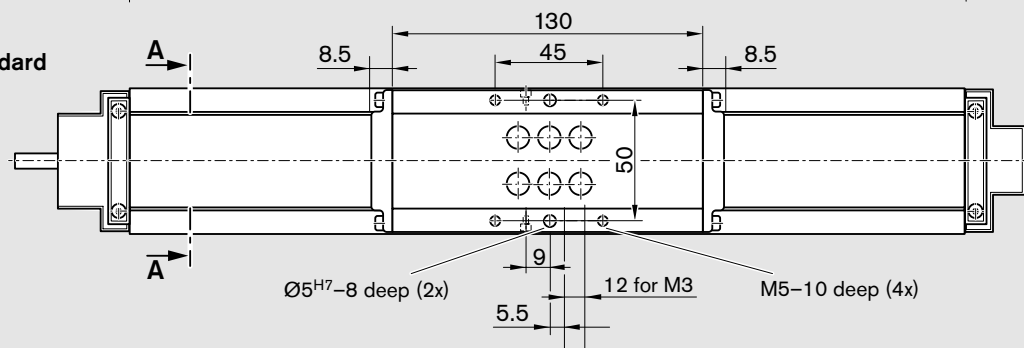

Version:
 Carriage, long

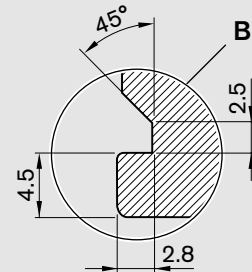
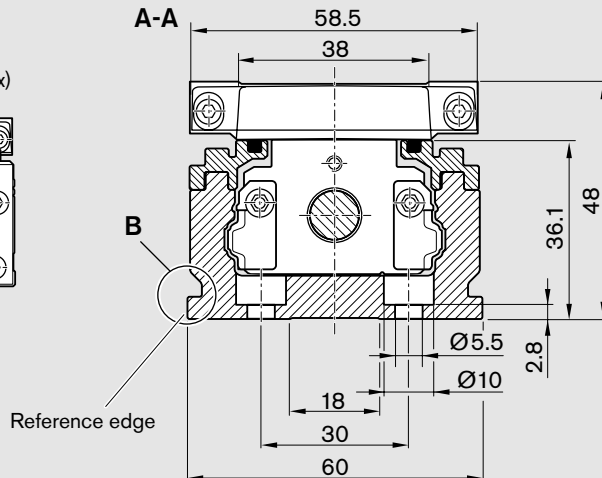
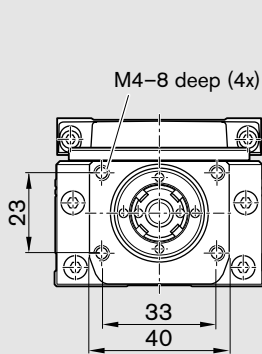
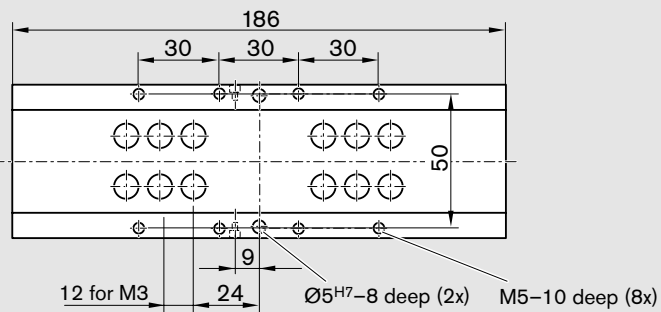

For fastening with
 clamping fixtures

Precision Module PSK 60 Dimension Drawings, Motor Attachment

OF01, OF02

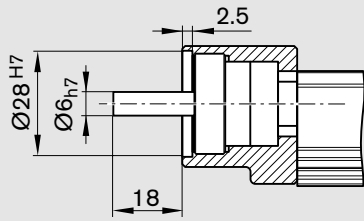

MF01, MF02

Motor with motor mount and coupling

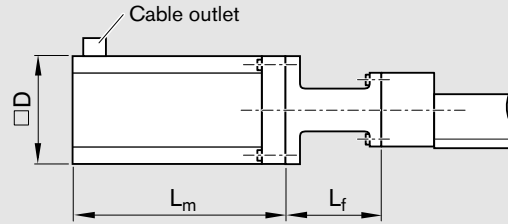

Motor type	Dimensions (mm)			
	D	L _f	without brake	L _m with brake
MSM 030B	60.0	50	111	144
MSK 030C	54.0	50	188	213
VRDM 368	57.2	50	116	157
MSM 020B	42.0	44	109	140

MF10, MF11

Integrated motor mount (NEMA 23 – Form D)

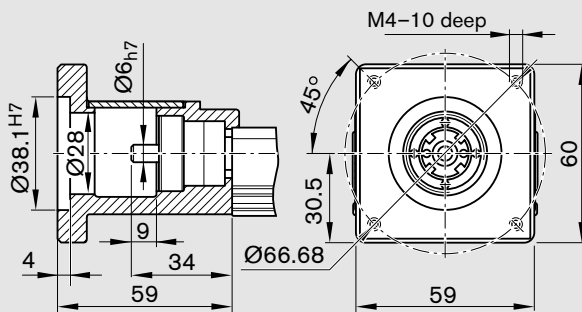

MF10, MF11

Motor with integrated motor mount and coupling

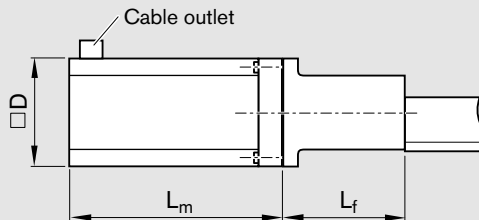

Motor type	Dimensions (mm)			
	D	L _f	without brake	L _m with brake
MSK 030C	54	59	188	213

Drawings not to scale!
For further information and dimensions, see "Motors."

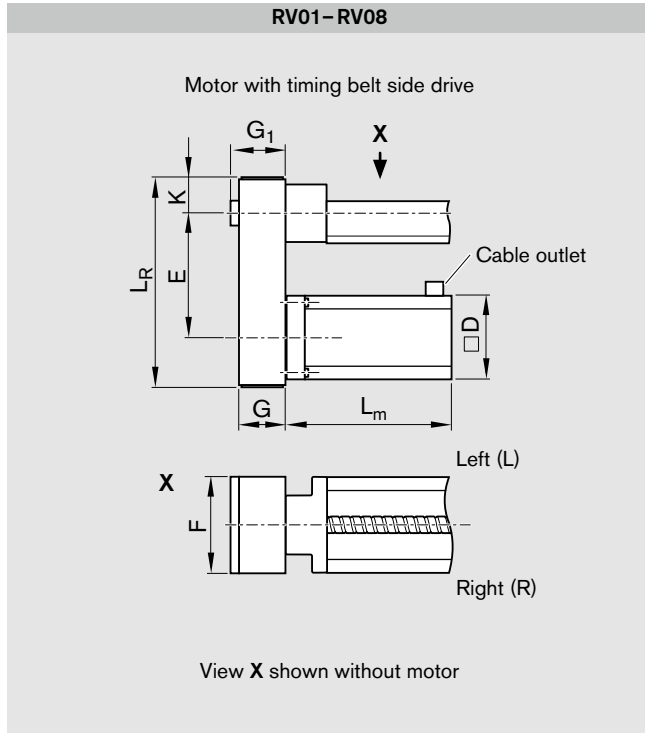

Version	Motor type	Dimensions (mm)									
		D	E		F	G	G ₁	K	without brake	L _m with brake	L _R
			i = 1	i = 1.5							
RV01 to RV08	MSM 030B	60	78	75	64.5	37	43.5	33.5	111	144	157
	MSK 030C	54	78	75	64.5	37	43.5	33.5	188	213	154

Precision Module PSK 90 Components and Ordering Data

Part number, length R1465 400 00, mm		Guideway	Drive unit			Carriage version										
Reference edge (RE)			Screw journal	Ball screw size d ₀ x P			Steel				Aluminum					
Version		Version		Without cover	Cover plate		Sealing strip		Without cover		Cover plate		Sealing strip			
RE left	RE right		Standard		Long	Standard	Long	Standard	Long	Standard	Long	Standard	Long	Standard	Long	
			1 carr.	2 carr.	1 carr.	2 carr.	1 carr.	2 carr.	1 carr.	2 carr.	1 carr.	2 carr.	1 carr.	2 carr.		
Without drive	OA01	OA01	without	50			01	02	03	04	-	-	-	-	-	
With ball screw, w/o motor mount	OF01	OF01 OF02	Ø9	01	02	03	01	02	03	04	21	22	23	24	40	41
			Ø9 with keyway	11	12	13										
With ball screw and motor mount	MF01	MF01 MF02	Ø9	01	02	03	01	02	03	04	21	22	23	24	40	41
W/ball screw and integrated mount	MF10	MF10 MF11	Ø9	30	31	32	01	02	03	04	21	22	23	24	40	41
With ball screw and timing belt side drive	RV01	RV01 to RV08	Ø9	61	62	63	01	02	03	04	21	22	23	24	40	41
	RV03															
	RV05															
	RV07															
			Ø9	51	52	53	01	02	03	04	21	22	23	24	40	41

Ordering example: See "Inquiry/Order" form

⚠ Please check whether the selected combination is a permissible one (load capacities, moments, maximum speeds, motor data, etc.)!

d₀ = screw diameter (mm)
 P = screw lead (mm)
 carr. = carriage(s)
 L = length

Motor attachment			Motor		Type of cover			Switches / Cable duct / Socket-plug	Documentation	
Gear ratio $i =$	Attach- ment kit ¹⁾	for motor			with- out	cover plate	strip		Standard report	Measure- ment report
			with brake	without brake						
-	00	-	00		00	-	-			
-	00	-	00		00	01	02			
-	03	MSK 040C	87	86	00	01	02	00	01	02
	04	VRDM 397	38	37						
		VRDM 3910	40	39						
06	MSM 040B	75	74							
-	31	NEMA 23-D²⁾	00		00	01	02	00	01	02
	32	MSK 030C	85	84						
	33	MSM 030C	73	72						
$i = 1$	24	MSK 030C	85	84	00	01	02	00	01	02
$i = 1.5$	26									
$i = 1$	25	MSM 030C	73	72						
$i = 1.5$	27									
$i = 1$	14	MSK 040C	87	86						
$i = 1.5$	16									
$i = 1$	15	MSM 040B	75	74						
$i = 1.5$	17									

- Attachment kit also available without motor (when ordering: enter "00" for motor).
- Use motors complying with the appropriate NEMA specification. Because of the varying shaft dimensions for NEMA-specification motors, the attachment kit does not include a coupling.
- Mounting side for switches: left (L) or right (R)

Switch mounting arrangements

A mounting duct is required for installation of the switches.

Refer to "Switch mounting arrangements" for more information on switch types and switch mounting.

Switches may only be mounted to one side of the Precision Module (left or right).

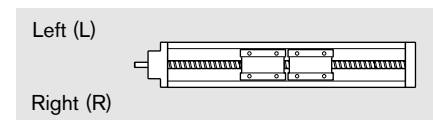

Precision Module PSK 90

Lengths and Hole Spacing

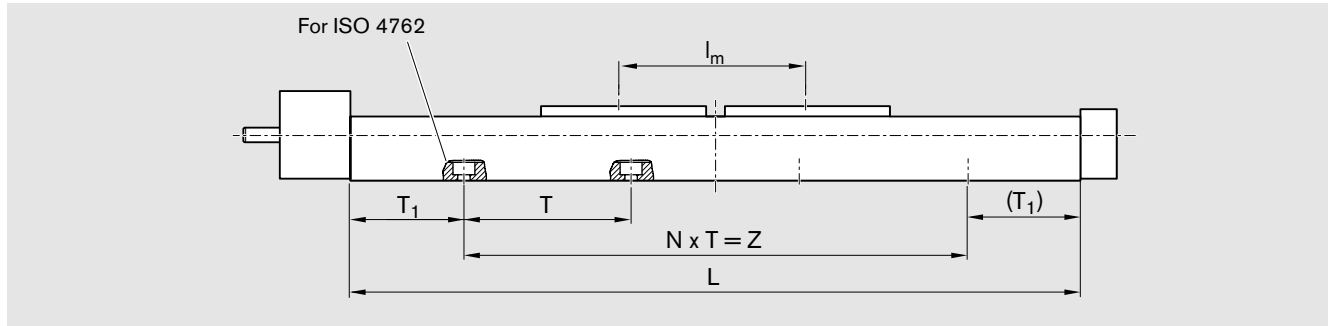

Length L

Type of cover	Number of carriages (carr.)	Carriage version	Standard length	Long
Without cover or with cover plate	1 carr.		$L = (\text{stroke} + 2 \cdot \text{excess travel}) + 100 \text{ mm}$	$L = (\text{stroke} + 2 \cdot \text{excess travel}) + 120 \text{ mm}$
	2 carr.		$L = (\text{stroke} + 2 \cdot \text{excess travel}) + l_m + 100 \text{ mm}$ $l_{m \min} = 90 \text{ mm}$	$L = (\text{stroke} + 2 \cdot \text{excess travel}) + l_m + 120 \text{ mm}$ $l_{m \min} = 110 \text{ mm}$
With sealing strip	1 carr.		$L = (\text{stroke} + 2 \cdot \text{excess travel}) + 190 \text{ mm}$	$L = (\text{stroke} + 2 \cdot \text{excess travel}) + 265 \text{ mm}$

l_m = center-to-center distance between carriages (consider $l_{m \min}$)

Stroke = maximum travel of carriage center between the outermost switch activation points

In most cases the recommended limit for excess travel (braking path) is:
Excess travel = $2 \cdot \text{screw lead } P$

Example

Ball screw 16 x 10
(Ball screw size = $d_o \times P$):
Excess travel = $2 \cdot 10 = 20 \text{ mm}$

Standard lengths of frame

Length L (mm)	T (mm)	T_1 (mm)	N	Z (mm)	Mounting holes for ISO 4762 screws
340	100	70	2	200	M6
440	100	70	3	300	
540	100	70	4	400	
640	100	70	5	500	
740	100	70	6	600	
840	100	70	7	700	
940	100	70	8	800	

Precision Module PSK 90 Dimension Drawings without Cover

All dimensions in mm
Drawings not to scale

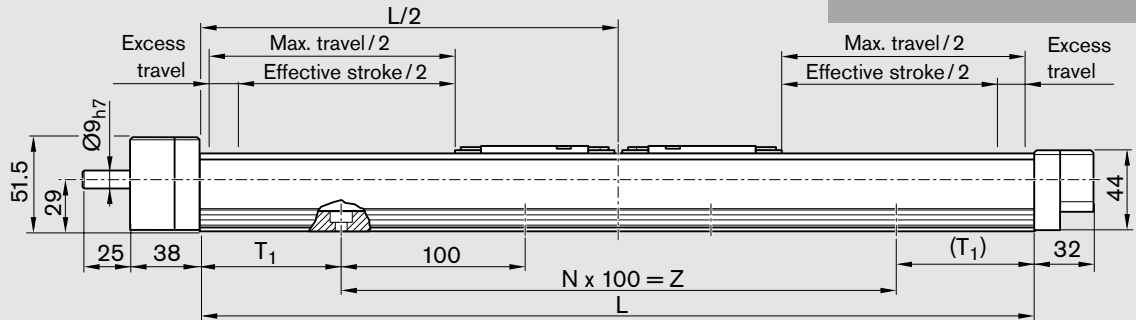
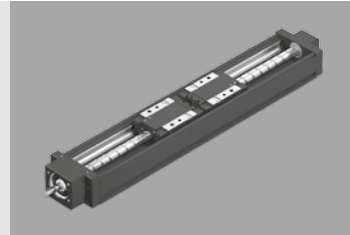

Version:
One or two carriages,
standard length

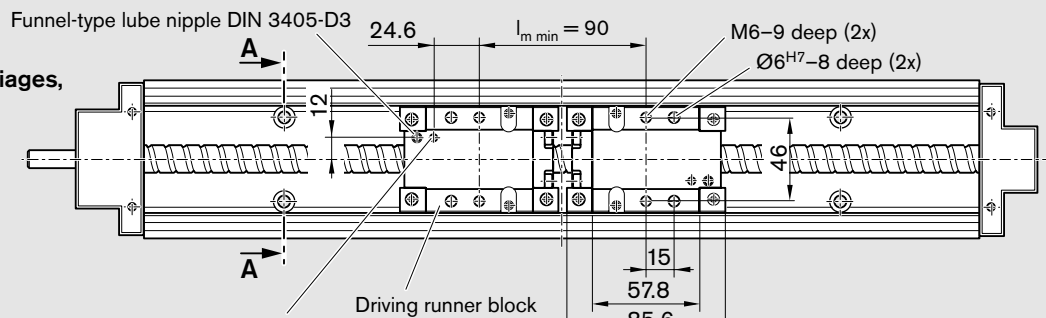

Version:
One or two carriages,
long

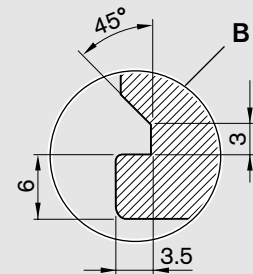
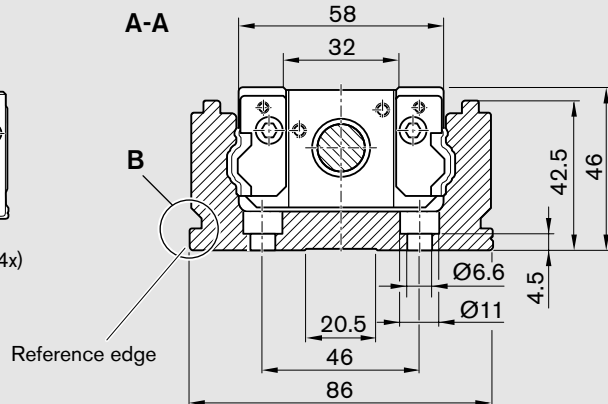
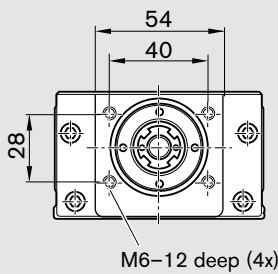
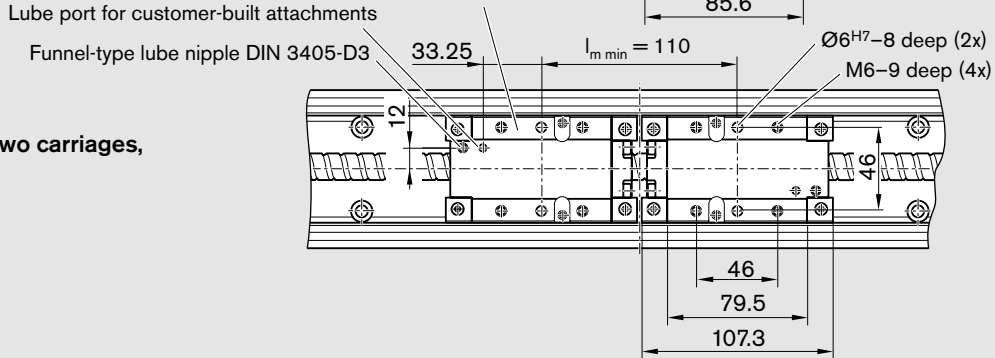

For fastening with
clamping fixtures

Precision Module PSK 90 Dimension Drawings with Cover Plate

All dimensions in mm
Drawings not to scale

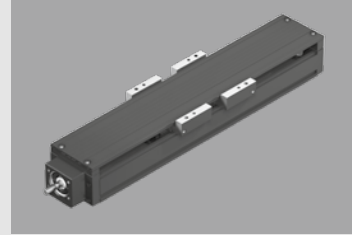

One-point lubrication (grease):
via funnel-type lube nipples DIN 3405-D3
on both sides

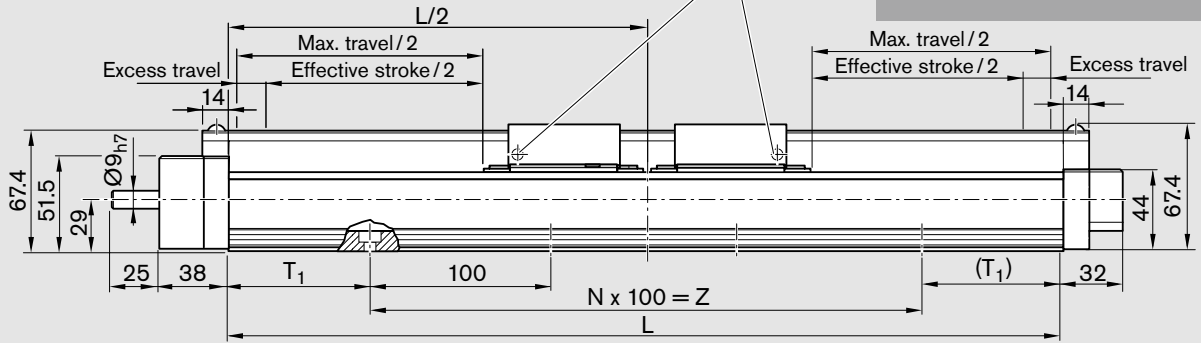

Version:
One or two carriages,
standard length

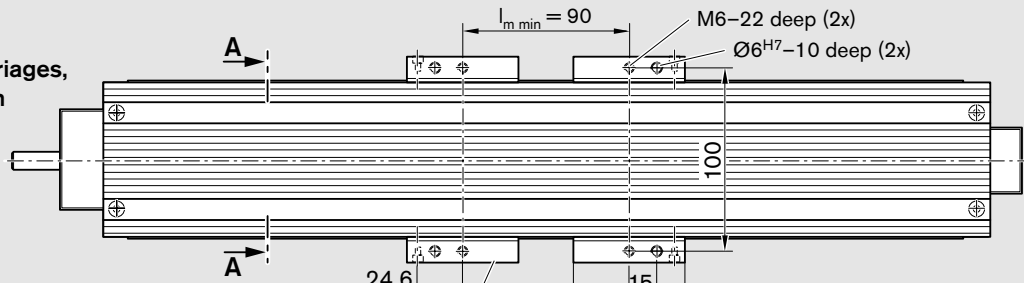

Version:
One or two carriages,
long

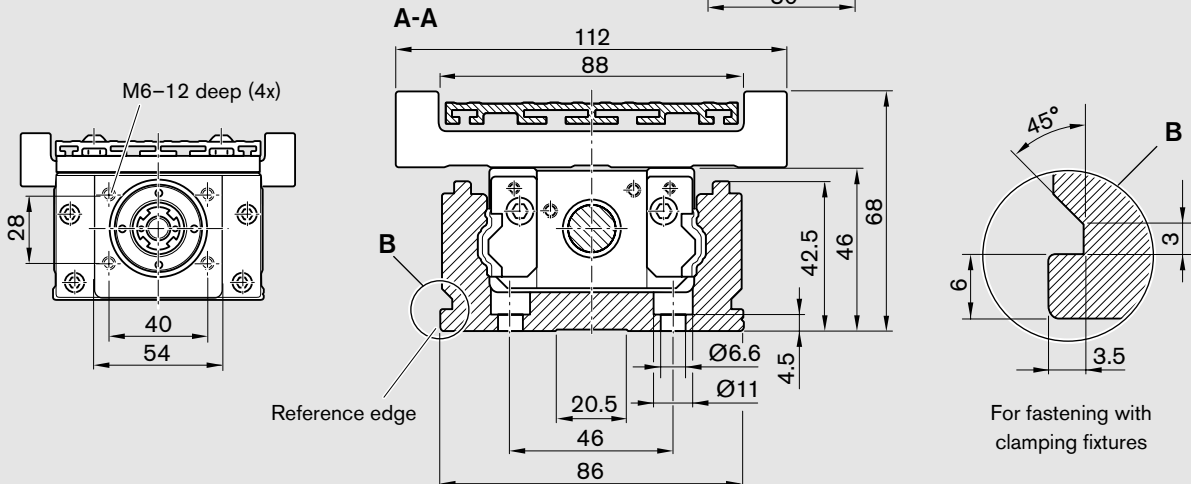
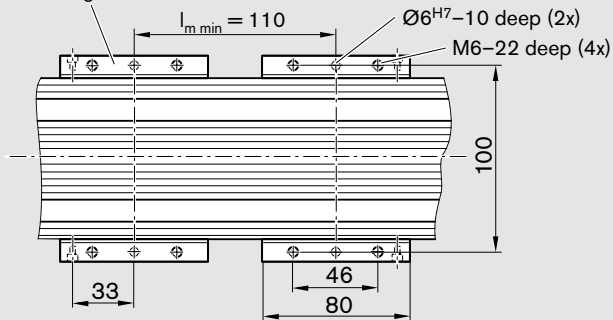

For fastening with
clamping fixtures

Precision Module PSK 90 Dimension Drawings with Sealing Strip

All dimensions in mm
Drawings not to scale

One-point lubrication (grease):
via funnel-type lube nipples DIN 3405-D3
on both sides

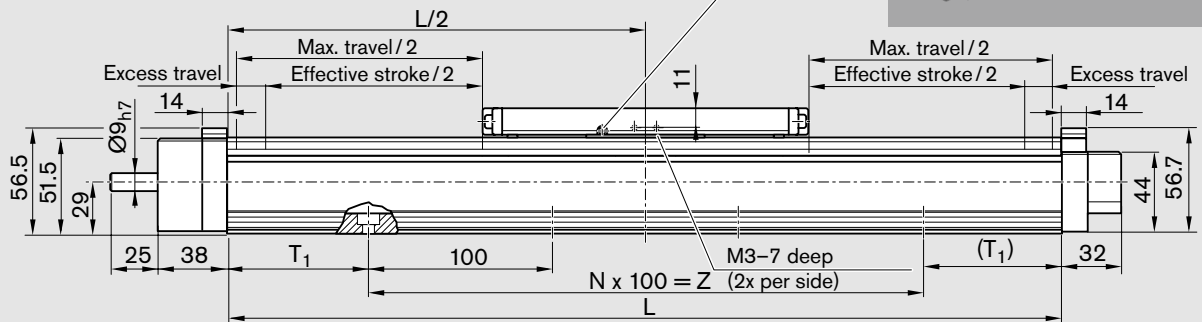
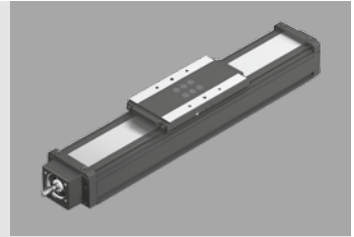

Version:
Carriage, standard
length

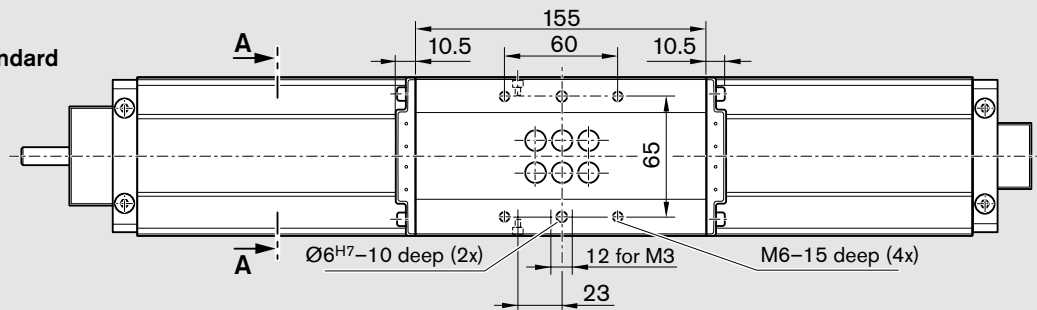

Version:
Carriage, long

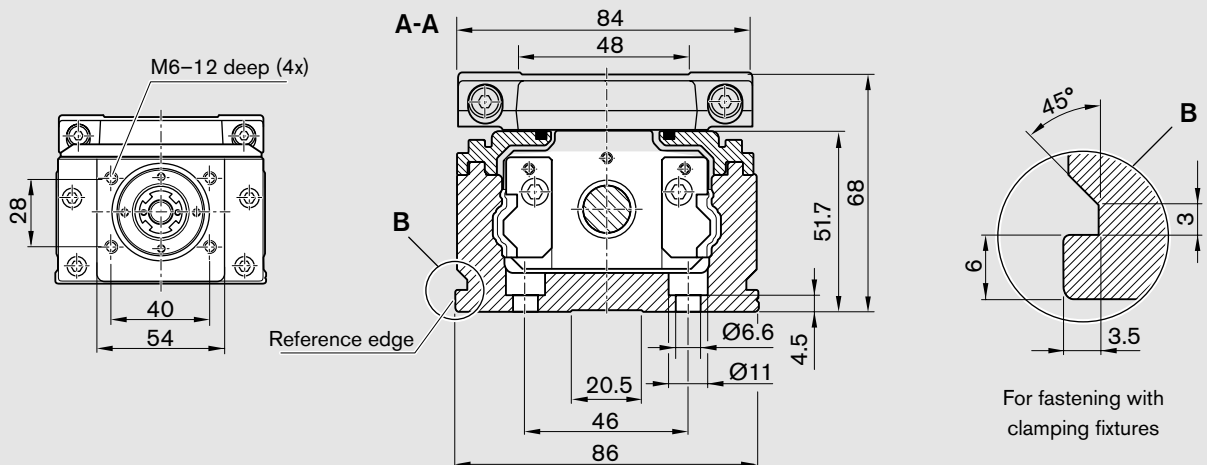
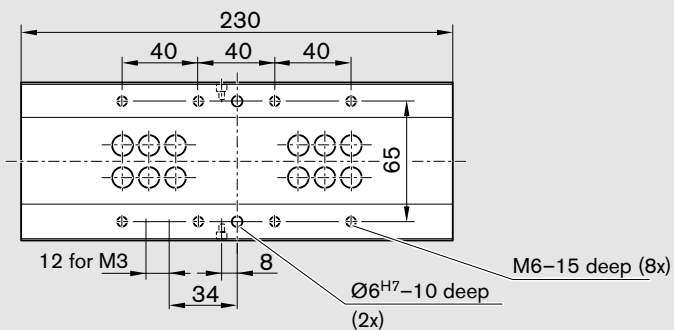

Precision Module PSK 90 Dimension Drawings, Motor Attachment

OF01, OF02

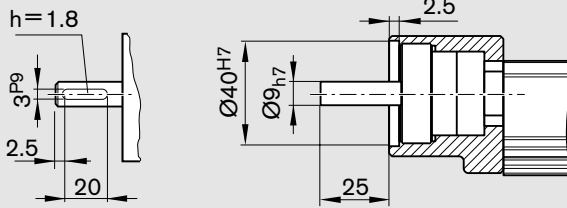

MF01, MF02

Motor with motor mount and coupling

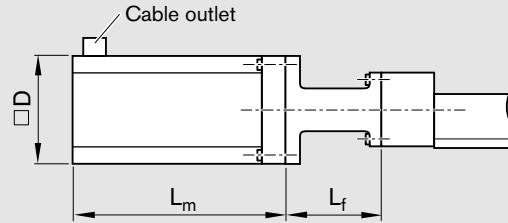

Motor type	Dimensions (mm)			
	D	L _f	without brake	L _m with brake
MSM 030C	60.0	72.0	138.5	171.5
MSM 040B	80.0	81.0	157.5	191.5
MSK 030C	54.0	75.0	188.0	213.0
MSK 040C	82.0	77.5	185.5	215.5
VRDM 397	85.0	77.5	110.0	156.5
VRDM 3910	85.0	77.5	140.0	186.5

MF10, MF11

Integrated motor mount (NEMA 23 – Form D)

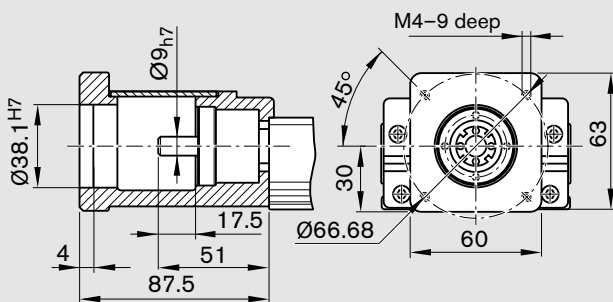

MF10, MF11

Motor with integrated motor mount and coupling

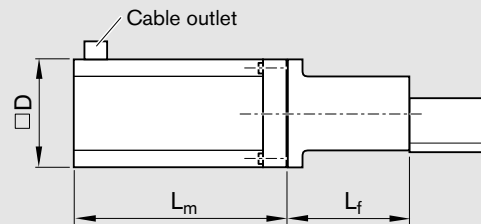

Motor type	Dimensions (mm)			
	D	L _f	without brake	L _m with brake
MSM 030C	60	87.5	138.5	171.5
MSK 030C	54	87.5	188.0	213.0

Drawings not to scale!
For further information and dimensions, see "Motors."

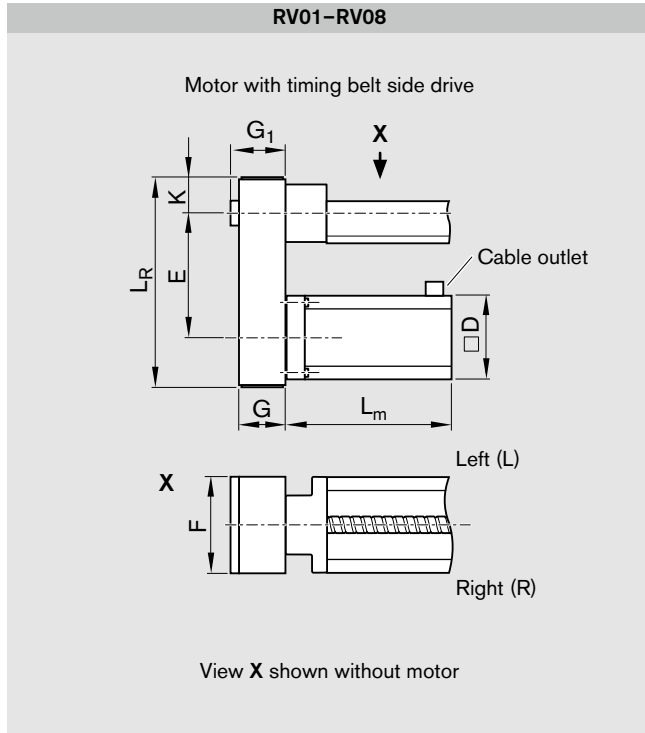

Version	Motor type	Dimensions (mm)										
		D	E		F	G	G ₁	K	L _m		L _R	
			i = 1	i = 1.5					without brake	with brake	i = 1	i = 1.5
RV01 to RV08	MSM 030C	60	103.5	115.0	64.5	37	43.5	33.5	138.5	171.5	180.0	191.5
	MSM 040B	80	122.0	122.0	88.0	51	57.0	45.5	157.5	191.5	231.0	231.0
	MSK 030C	54	103.5	115.0	64.5	37	43.5	33.5	188.0	213.0	180.0	191.5
	MSK 040C	80	122.0	122.0	88.0	51	57.0	45.5	185.5	215.5	231.0	231.0

Switch Mounting Arrangements

Overview of switching system

- 1 Switch
- 2 Switching cam
- 3 Cable duct (aluminum alloy, black anodized)
- 4 Socket head cap screw with washer

Notes for mounting

A mounting duct is required for installation of the switches.

 **Short stroke:**
Consider the length of the switch!

Mounting side:
Switches may be mounted on the left (L) or right (R) side of the module.

For two-carriage versions:
Switch actuation by the driving runner block (on the motor side).

Ordering the switches and accessories

Refer to the following table for part numbers.

Accessories can also be ordered separately.

Switching system

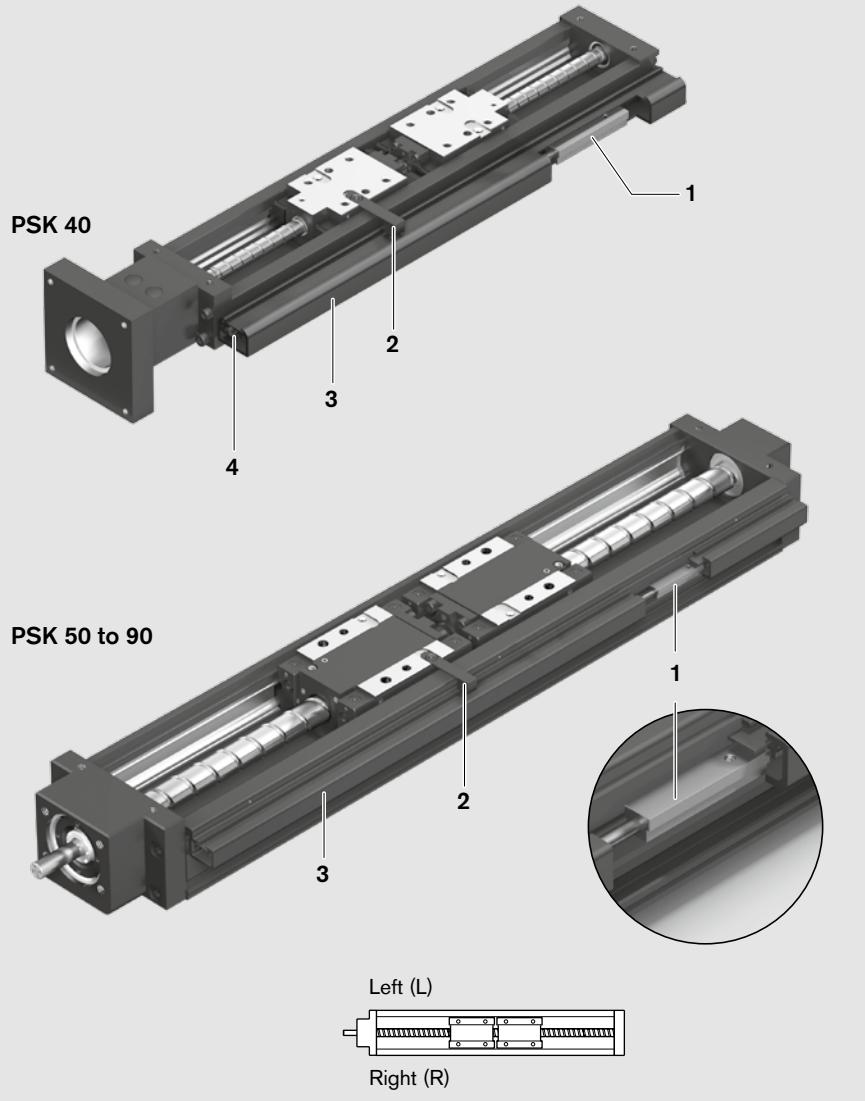

Item		Part numbers		
		PSK 40	PSK 50	PSK 60 and PSK 90
1	Switches			
	- Reed sensor	R9871 469 49	R9871 469 49	R9871 469 49
	- Hall sensor	R9871 461 25	R9871 461 25	R9871 461 25
2	Cable duct	R0396 620 29	R201KDUCT 5	R201KDUCT 6
3	Switching cam			
	- For PSK without cover or with cover plate	R1419 000 12	R1419 000 10	R1419 000 04
	- For PSK with sealing strip	-	R1419 000 11	R1419 000 05

Cable duct

Function

- To accommodate and secure switches
- To house cables

Mounting instructions for PSK 40

The cable duct is fastened to the same side as the switches and fixed to the end blocks of the Precision Module with socket head cap screws and washers (included in delivery).

Mounting instructions for PSK 50 to PSK 90

The cable duct is mounted to the same side as the switches by snapping it into the T-slots on the frame of the Precision Module and securing it with set screws. The set screws (M) are supplied along with the duct.

Dimensions for cable duct

Dimensions	PSK 50	PSK 60	PSK 90
A (mm)	21.7	25.2	25.2
B (mm)	15.0	15.0	15.0
C (mm)	11.5	11.5	11.5
D (mm)	16.5	16.5	16.5
M (mm)	M2.0	M2.5	M2.5

Installation dimensions for versions without cover or with cover plate

Dimensions	PSK 50	PSK 60	PSK 90
E (mm)	15.2	15.8	15.4
F (mm)	25.8	32.8	45.8
G (mm)	19.7	22.6	25.8
H (mm)	6.0	6.0	6.0

Installation dimensions for version with sealing strip

Dimensions	PSK 50	PSK 60	PSK 90
E (mm)	15.2	15.8	15.2
F (mm)	28.2	35.7	50.2
G (mm)	12.2	13.0	13.0
H (mm)	12.5	14.0	14.0
I (mm)	3.3	1.9	7.4

Cable duct PSK 40

Arrangement of switching cam and cable duct

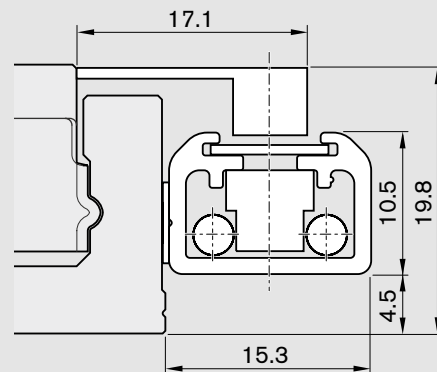

Cable duct PSK 50 to PSK 90

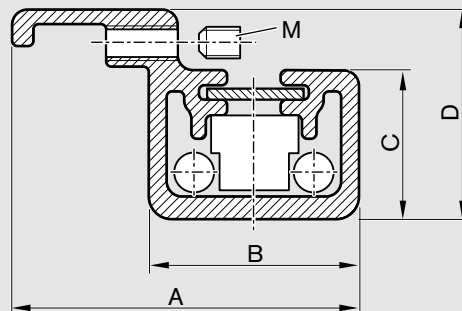

Arrangement of switching cam and cable duct

- PSK without cover or with cover plate
- PSK with sealing strip

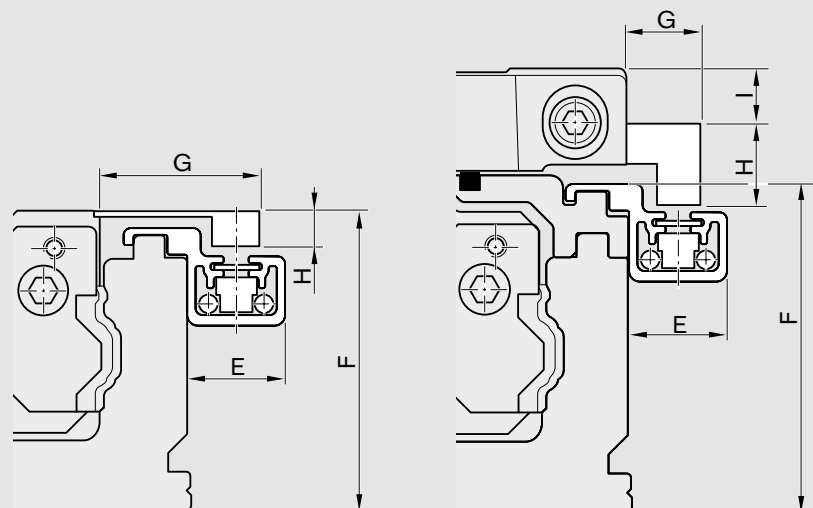

Switch Mounting Arrangements

Switches

The switches for Precision Modules PSK are magnetic field sensors with potted cable.

Versions

- Hall sensor, PNP NC
- Reed sensor (changeover)

Notes for mounting

Switches may only be mounted to one side of the Precision Module (left or right).

A mounting duct is required for installation of the switches.

The switches are pushed into the slots of the mounting duct and fixed with set screws.

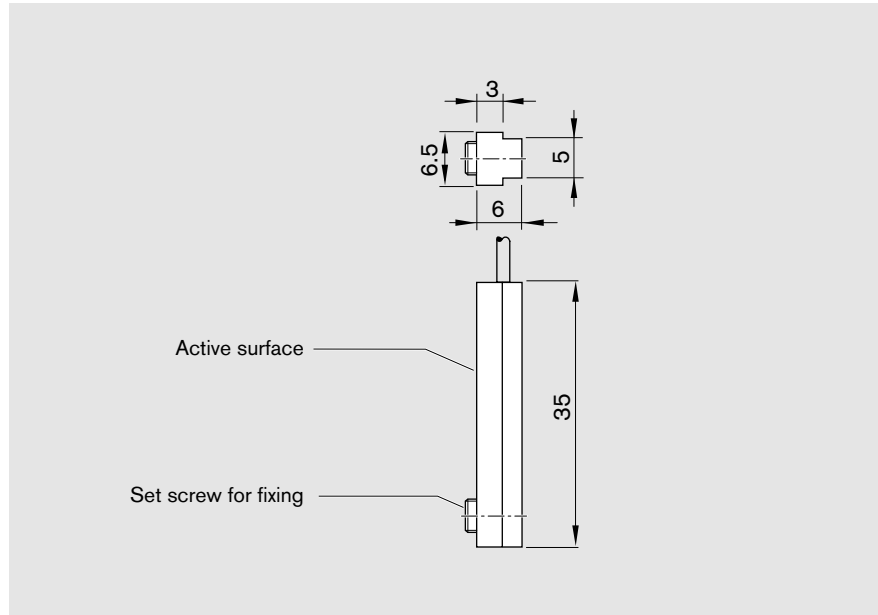

Technical data

Hall sensor	
Contact type	PNP NC
Operating voltage	3.8–30 V DC
Current consumption	max. 10 mA
Output current	max. 20 mA
Cable length	2000 mm
Protection class	IP 66
Short-circuit protection	No

Reed sensor	
Contact type	Changeover
Switching voltage	max. 100 V DC
Switching current	max. 500 mA
Cable length	2000 mm
Protection class	IP 66
Caution: 2 switching points	

Pin assignment

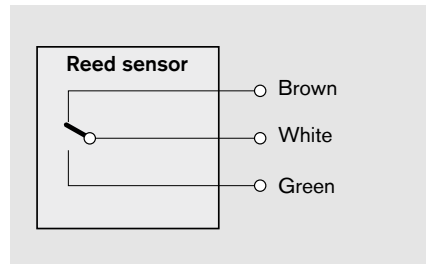
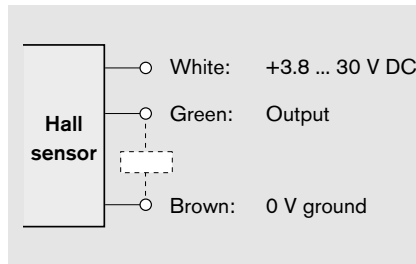

Motors

AC Servo Motors MSK

Notes

All MSK motors have an absolute multi-turn encoder (Hyperface, 128 increments with 4096 revolutions).

The motors can be supplied complete with controller and control unit. For more information on motors, controllers and control systems, see Rexroth catalog "Controllers Servo Motors."

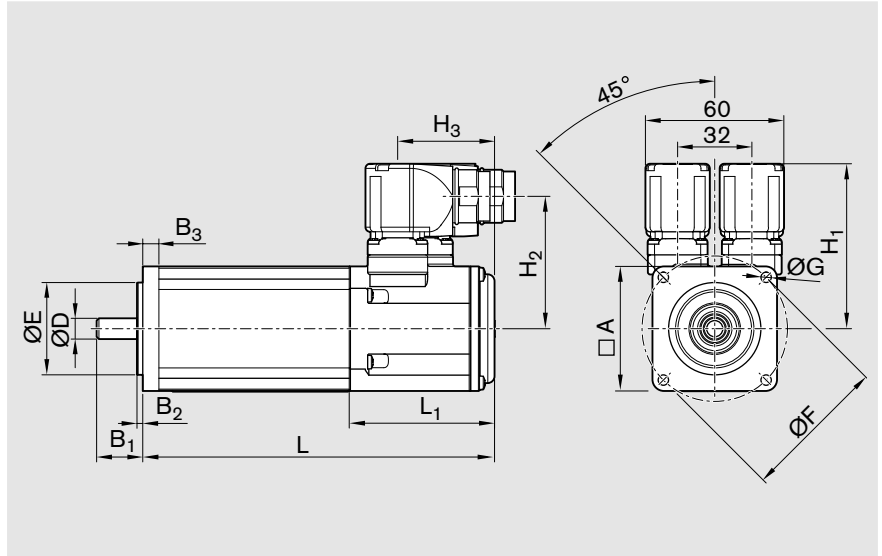

Dimensions

Motor type	Dimensions (mm)													
	A	B_1	B_2	B_3	ϕD k6	ϕE j6	ϕF	ϕG	H_1	H_2	H_3	L_1	L without brake	L with brake
MSK 030C	54	20	2.5	7	9	40	63	4.5	71.5	57.4	42	-	188.0	213.0
MSK 040C	82	30	2.5	8	14	50	95	6.6	83.5	69.0	31	42.5	185.5	215.5

Motor data

Motor type	Unit	MSK030C-0900	MSK040C-0600
Maximum rotary speed	n_{max} (min^{-1})	9000	6000
Maximum permissible torque	M_{max} (Nm)	4	8.1
Rated torque	M_N (Nm)	0.8	2.7
Motor mass moment of inertia	J_m (10^{-6} kgm^2)	30	140
Mass without brake	m_m (kg)	2.1	3.6
Holding brake			
Holding torque	M_{br} (Nm)	1.0	4.0
Brake mass moment of inertia	J_{br} (10^{-6} kgm^2)	7	23
Mass of brake	m_{br} (kg)	0.25	0.32

Motors

AC Servo Motors MSM

Notes

All MSM motors have an absolute multi-turn encoder.

The motors can be supplied complete with controller and control unit. For more information on motors, controllers and control systems, see Rexroth catalog "Controllers Servo Motors."

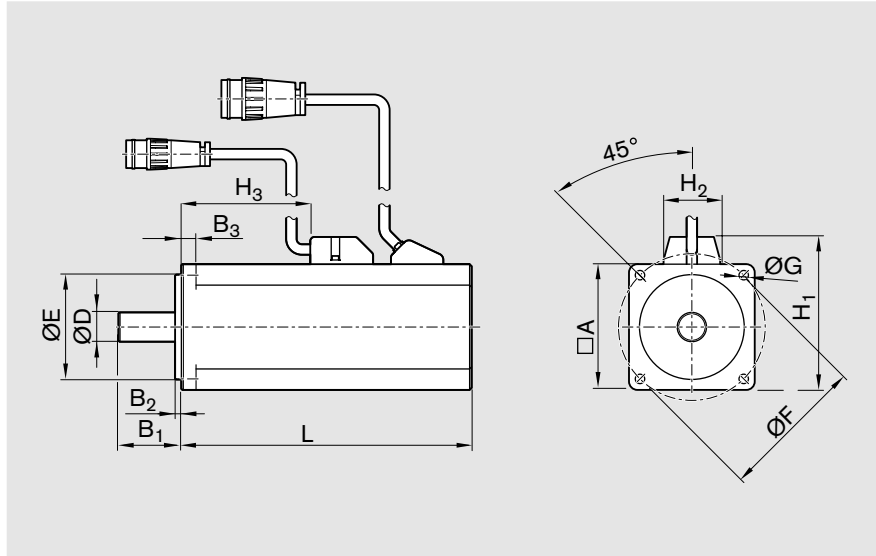

Dimensions

Motor type	Dimensions (mm)												
	A	B ₁	B ₂	B ₃	ØD h6	ØE h7	ØF	ØG	H ₁	H ₂	H ₃	L without brake	L with brake
MSM 020B	42	24	2	7	8	22	48	3.4	55	27	38.8	109.0	140.0
MSM 030B	60	30	3	7	11	50	70	4.5	73	27	34.0	111.0	144.0
MSM 030C	60	30	3	7	14	50	70	4.5	73	27	61.5	138.5	171.5
MSM 040B	80	35	3	8	19	70	90	6.0	93	27	76.0	157.5	191.5

Motor data

Motor type	Unit	MSM 020B	MSM 030B	MSM 030C	MSM 040B
Maximum rotary speed	n_{max} (min ⁻¹)	3000	3000	3000	3000
Maximum permissible torque	M_{max} (Nm)	0.95	1.91	3.80	7.10
Rated torque	M_N (Nm)	0.32	0.64	1.20	2.40
Motor mass moment of inertia	J_m (10 ⁻⁶ kgm ²)	3.2	10.0	17.0	67.0
Mass without brake	m_m (kg)	0.5	0.96	1.5	3.1
Holding brake					
Holding torque	M_{br} (Nm)	0.29	1.27	1.27	2.45
Brake mass moment of inertia	J_{br} (10 ⁻⁶ kgm ²)	0.4	3.0	3.0	8.0
Mass of brake	m_{br} (kg)	0.2	0.4	0.4	0.7

3-phase Stepping Motors VRDM

Notes

All VRDM motors are equipped with an encoder for rotation monitoring.

The motors can be supplied complete with controller and control unit. For more information on motors, controllers and control systems, see Rexroth catalog "Controllers Servo Motors."

Key to illustration

- 1 Motor connector
- 2 Brake
- 3 Encoder connector

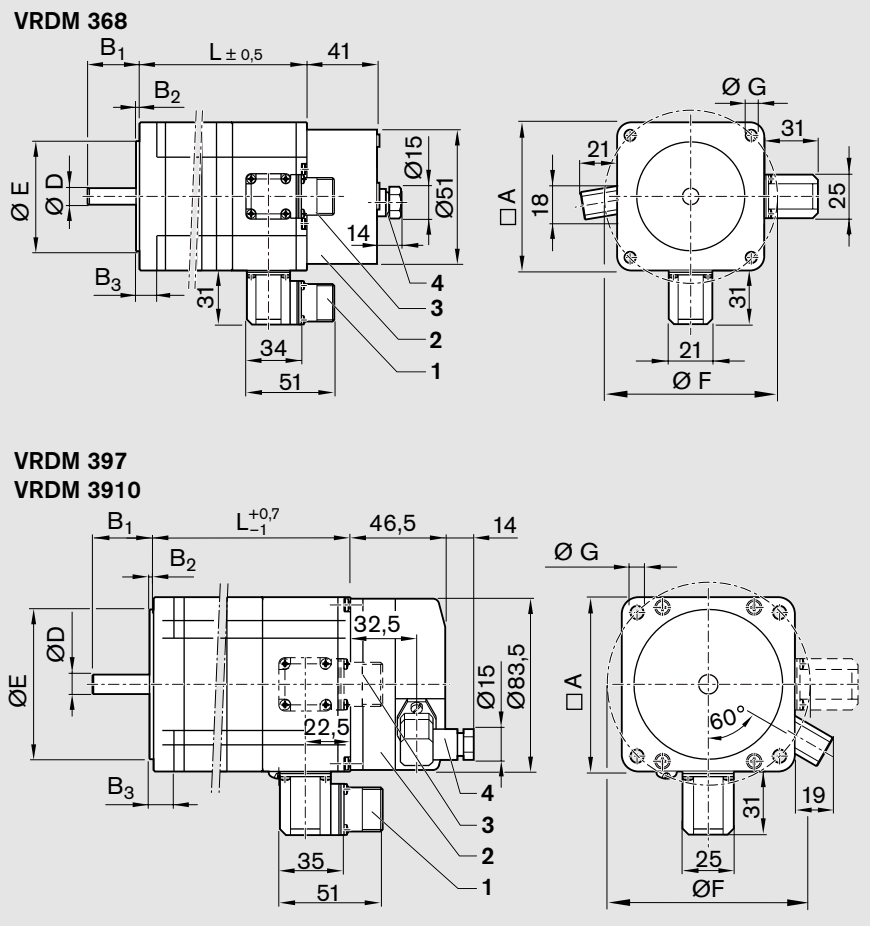

Dimensions

Motor type	Dimensions (mm)									
	A	B ₁	B ₂	B ₃	ØD	ØE	ØF	ØG	L without brake	L with brake
VRDM 368	57.2	21	1.6	5	8 _{-0.013}	38.1 _{±0.025}	66.7	5.2	116.0	157.0
VRDM 397	85.0	30	2.0	10	12 _{h6}	60.0 _{h8}	99.0	6.5	110.0	156.5
VRDM 3910	85.0	30	2.0	10	12 _{h6}	60.0 _{h8}	99.0	6.5	140.0	186.5

Motor data

Motor type	Unit	VRDM 368	VRDM 397	VRDM 3910
Maximum permissible torque	M _{max} (Nm)	1.50	2.00	4.00
Motor mass moment of inertia	J _m (10 ⁻⁶ kgm ²)	38	110	220
Motor holding torque	M _m (Nm)	1.74	2.26	4.52
Mass without brake	m _m (kg)	1.1	2.5	3.1
Step count	z (-)	200 / 400 / 500 / 1000 / 2000 / 4000 / 5000 / 10000		
Stepping angle per step	α (°)	1.8 / 0.9 / 0.72 / 0.36 / 0.18 / 0.09 / 0.072 / 0.036		
Encoder resolution		1000 increments/revolution		
Holding brake				
Brake holding torque	M _{br} (Nm)	1	6	6
Brake mass moment of inertia	J _{br} (10 ⁻⁶ kgm ²)	1.6	20	20
Mass of brake	m _{br} (kg)	0.5	1.5	1.5

Mounting

General notes

⚠ Do not mount or support the Precision Module by the end blocks! The frame is the main load-bearing part!

Precision Modules can be mounted either with screws in the frame itself or with external clamping fixtures. When mounting Precision Modules, please note the maximum tightening torques listed in the table.

Mounting with screws in the frame

The reference edge on the frame facilitates alignment of the Precision Module. Suitable for cover options:

- Without cover
- With cover plate (remove cover plate before mounting the module). For installation dimensions, see the relevant dimension drawings.

Mounting with clamping fixtures, PSK 50 to PSK 90

The reference edge cannot be used in the region of the clamping fixtures. Suitable for all cover options.

Clamping fixtures

Recommended number:
- 3 per 500 mm and side

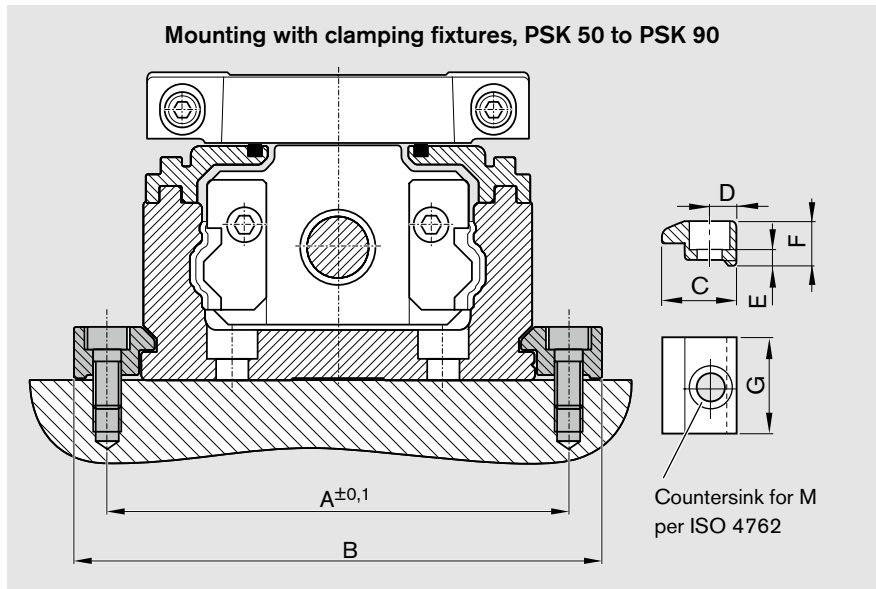
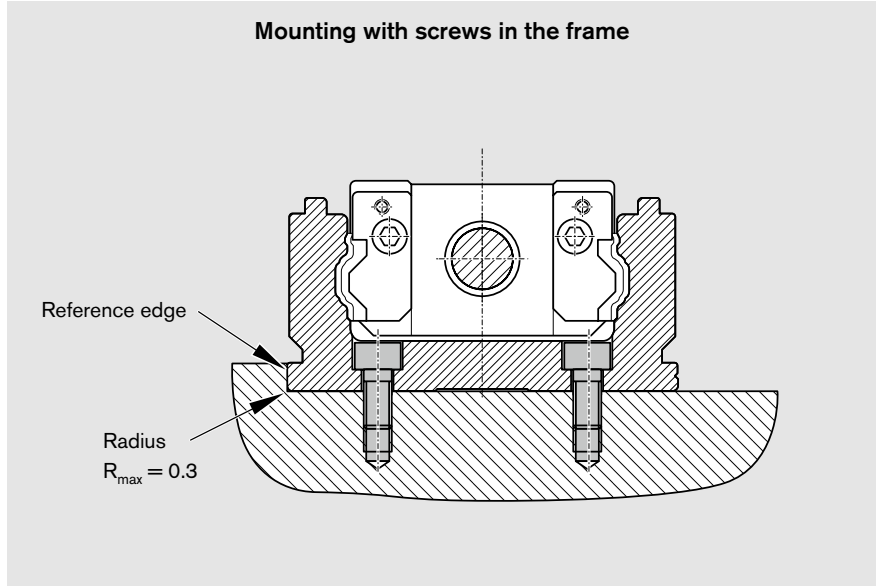

Precision Module	Part numbers Clamping fixtures	Dimensions (mm)							
		A	B	C	D	E	F	G	M
PSK 50	R1419 010 02	60	70	12.5	5.0	4.0	8.5	20	M4
PSK 60	R1419 010 01	72	85	15.0	6.5	4.8	10.0	22	M5
PSK 90	R1419 010 00	100	115	17.5	7.5	5.8	12.0	25	M6

Tightening torques for the mounting screws

- At friction factor 0.125
- Strength class 8.8

		M3	M4	M5	M6
8.8	(Nm) max.	1.3	2.7	5.5	9.5

Lube Ports

General notes

The lubrication system on Precision Modules has been designed for grease lubricants (grease gun). The lube port supplies lubricant to both the Rail System guideway and the Precision Ball Screw Assembly. If the module has two carriages, **both** of these must be lubricated.

Lubricant

Lithium soap grease	PSK 40	PSK 50 to PSK 90
DIN 51825	KP00K	KP2K
DIN 51818	NLGI 00	NLGI 2

PSK without cover

- PSK 40: One-point lubrication is possible via the lube port for grease gun on each carriage. Remove the set screw from the lube hole, apply lubricant, then drive the set screw in again.
- PSK 50, PSK 60, PSK 90: One-point lubrication at either of the two funnel-type lube nipples DIN 3405-D3 per carriage.
- One-point lubrication through customer-built attachment: This can be achieved in all PSK types by using the lube port in the carriage. The lube ports are closed with set screws for shipment. Before using the lube ports, the set screws must be removed and O-rings inserted to seal off the customer-built attachment.

Precision Module	O-ring DIN 3771	Part numbers
PSK 40 to PSK 60	3 x 1	R3411 118 01
PSK 90	5 x 1.5	R3411 108 01

PSK with cover plate or sealing strip

One-point lubrication at either of the two funnel-type lube nipples (1) DIN 3405-D3 per carriage.

For short-stroke applications, please contact us regarding the lubrication arrangements:

- PSK 40: stroke < 50 mm
- PSK 50: stroke < 70 mm
- PSK 60: stroke < 95 mm
- PSK 90: stroke < 135 mm

Without cover

PSK 40

Lube port for grease gun and for customer-built attachment

PSK 50 to PSK 90

Funnel-type lube nipple
DIN 3405-D3

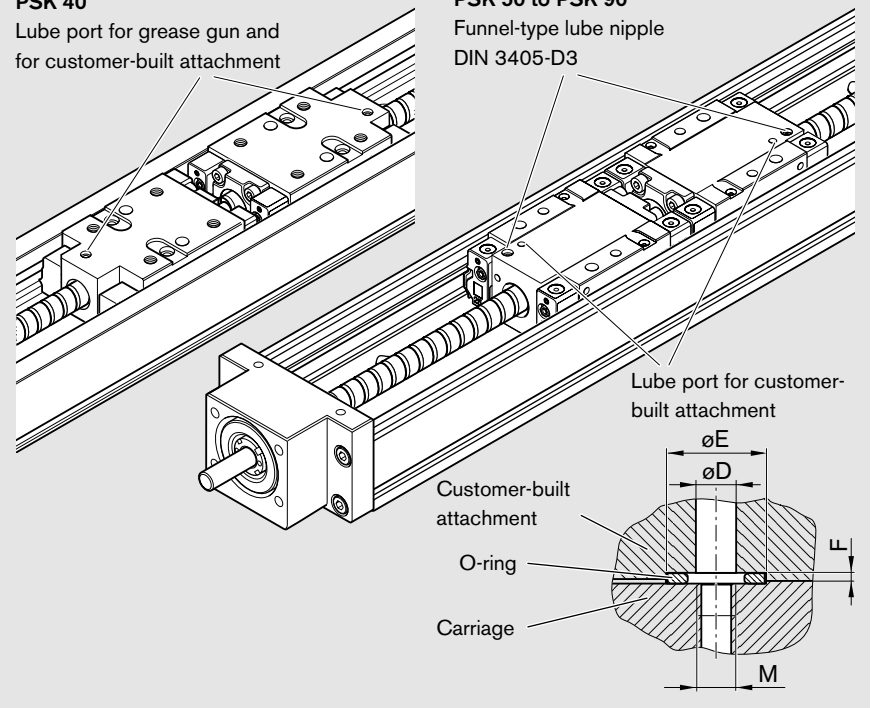

Carriage: standard length

PSK 40

PSK 50 to PSK 90

Carriage: long

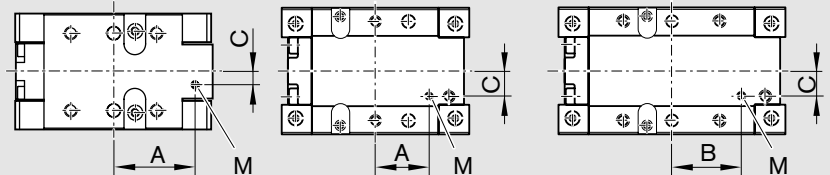

Precision Module	PSK 40	PSK 50	PSK 60	PSK 90
A (mm)	19.0	18.2	16.0	24.6
B (mm)	–	–	22.0	33.3
C (mm)	3.0	6.5	9.0	12.0
D (mm)	2.5	2.5	2.5	4.0
E (mm)	5.0	5.0	5.0	8.0
F (mm)	0.6 +0.1	0.6 +0.1	0.7 +0.1	0.5 +0.1
M (mm)	M2	M2.5	M3	M4

Cover plate

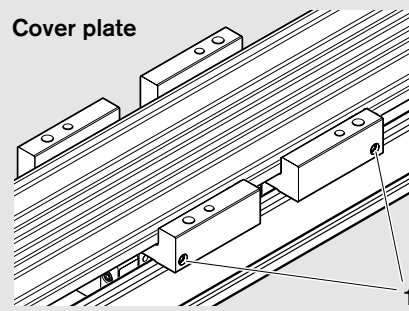

Sealing strip

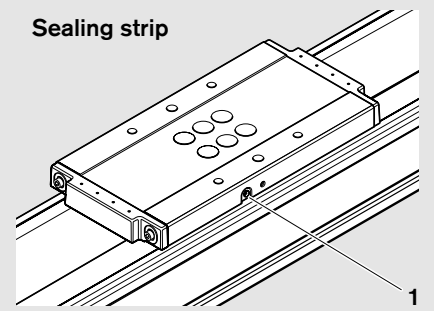

Documentation

Standard report

Option no. 01

The standard report serves to confirm that the checks listed in the report have been carried out and that the measured values lie within the permissible tolerances.

Checks listed in the standard report:

- Functional checks of mechanical components
- Functional checks of electrical components
- Design is in accordance with order confirmation

Frictional moment of complete system

Option no. 02

The moment of friction M is measured over the entire travel range.

M = friction moment (N)
 t = travel time (ms)

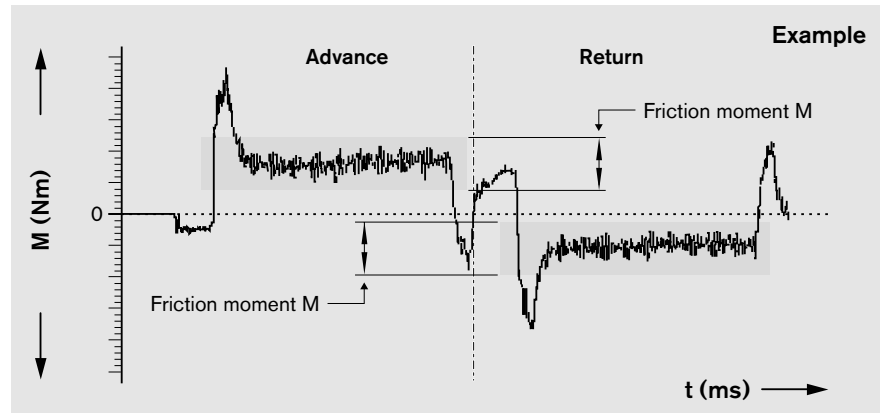

Lead deviation of ball screw

Option no. 03

A measurement report of the lead deviation δ over the measured travel s (see illustration) is provided in table form in addition to the graph.

δ = deviation (μm)
 s = measured travel (mm)

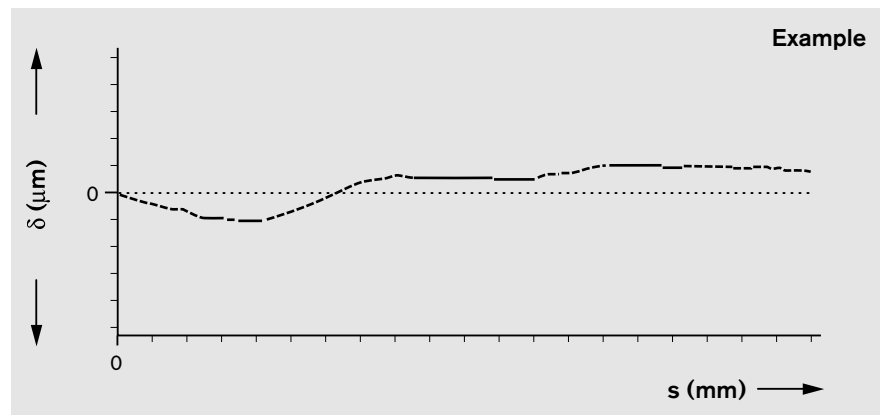

Travel accuracy

Option no. 04

Yawing

Yawing is angular deviation about the vertical axis. This angular deviation is converted to a linear deviation δ in μm on the basis of a standard length and is plotted on the graph. The base length is given in the graph.

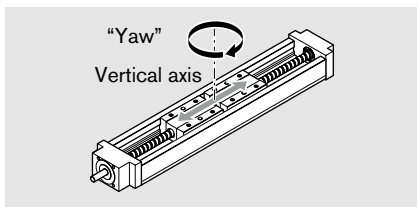

Several measuring points are passed during the total travel. The yawing and pitching deviations are measured at these points.

Note

The measurements are taken with the module screwed down and assuming an ideally flat mounting base surface.

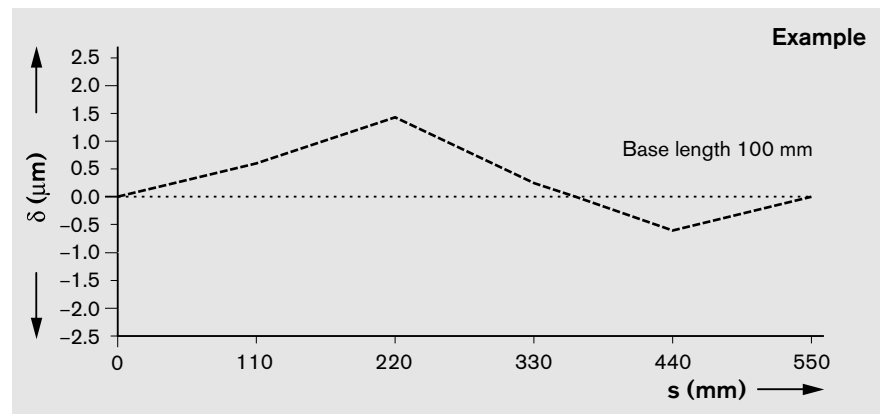

Documentation

Pitching

Pitching means angular deviation about the horizontal axis. This angular deviation is converted to a linear deviation δ in μm on the basis of a standard length and is plotted on the graph. The base length is given in the graph.

In addition to graphical representation (see illustrations), a measurement report is supplied in table form.

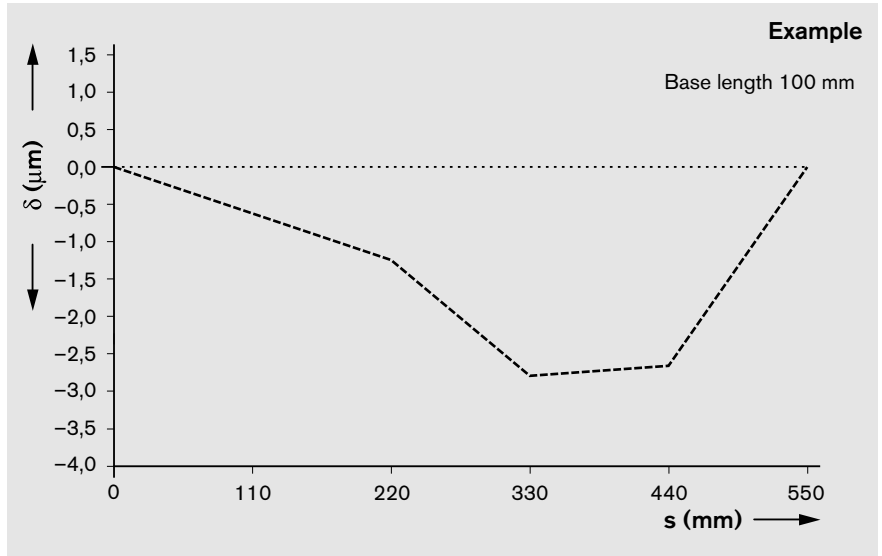
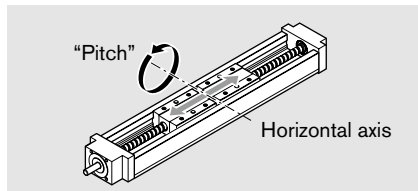

Positioning accuracy per VDI/DGQ 3441

Option no. 05

Measurement points are selected at irregular intervals along the travel range. This allows even periodical deviations δ in μm to be detected during positioning. Each measurement point is approached several times from both sides. This gives the following parameters.

δ = deviation (μm)
 s = measured travel (mm)

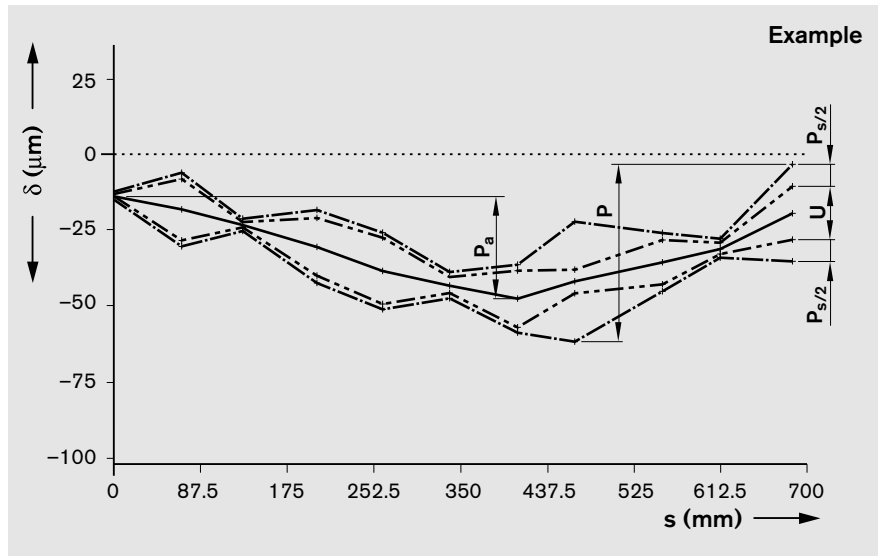

Positioning accuracy P

The positioning accuracy corresponds to the total deviation. It encompasses all the systematic and random deviations during positioning. The positioning

accuracy takes the following characteristic values into consideration:

- Position deviation
- Reversal range
- Position variation range

Position deviation P_a

The position deviation corresponds to the maximum difference arising in the mean values of all the measurement points. It describes systematic deviations.

Reversal range U

The reversal range corresponds to the difference in mean values of the two approach directions.

The reversal range is determined at every measurement point. It describes systematic deviations.

Position variation range P_s

The position variation range describes the effects of random deviations. It is determined at every measurement point.

Inquiry/Order Form

Bosch Rexroth Corporation
 14001 South Lakes Drive
 Charlotte, NC 28273

Phone: (704) 583-4338 / 800-438-5983
 Fax: (704) 583-0523

www.boschrexroth-us.com

Rexroth Precision Module PSK

Ordering example

Ordering data		Description
Precision Module PSK 90		Designation
Part number: R1465 400 00, 740 mm		PSK 90, length = 740 mm
Version	= MF01	With motor mount and motor, as shown in diagram MF01
Guideway	= 18	Rail system, 740 mm long
Drive unit	= 03	Ball screw 16 x 16
Carriage	= 24	Two carriages, long, steel version for cover plate
Motor attachment	= 03	With motor mount for motor MSK 040C
Motor	= 87	Motor MSK 040C with brake
Cover	= 01	With cover plate
1st switch	= 21	Reed sensor
2nd switch	= 22	Hall sensor
3rd switch	= 21	Reed sensor
Cable duct	= 25	Cable duct supplied loose
Switching cam	= 30	Switching cam for version without cover or with cover plate
Documentation	= 01	Standard report

To be completed by customer: Inquiry / Order

Precision Module PSK _____

Part number: R _____, length _____ mm

Version =
 Guideway =
 Drive unit =
 Carriage =
 Motor attachment =
 Motor =
 Cover =
 1st switch = - + mm
 2nd switch = - ± mm
 3rd switch = - - mm
 Cable duct = , mm
 Switching cam =
 Documentation =

Single parts:

(Part number): R _____
 R _____
 R _____
 R _____

Quantity _____ Order of: _____ pcs, _____ per month, _____ per year, per order, or _____
 Comments: _____

From
 Company: _____

Name: _____

Address: _____

Department: _____

Telephone: _____

Telefax: _____

Bosch Rexroth Corporation

Linear Motion and
Assembly Technologies
14001 South Lakes Drive
Charlotte, NC 28273
Telephone (800) 438-5983
Facsimile (704) 583-0523
www.boschrexroth-us.com

• Your sales partner •

The data specified above only serve to describe the product. No statements concerning a certain condition or suitability for a certain application can be derived from our information. The information given does not release the user from the obligation of own judgment and verification. It must be remembered that our products are subject to a natural process of wear and aging.