

# Ball Transfer Units

The Drive & Control Company

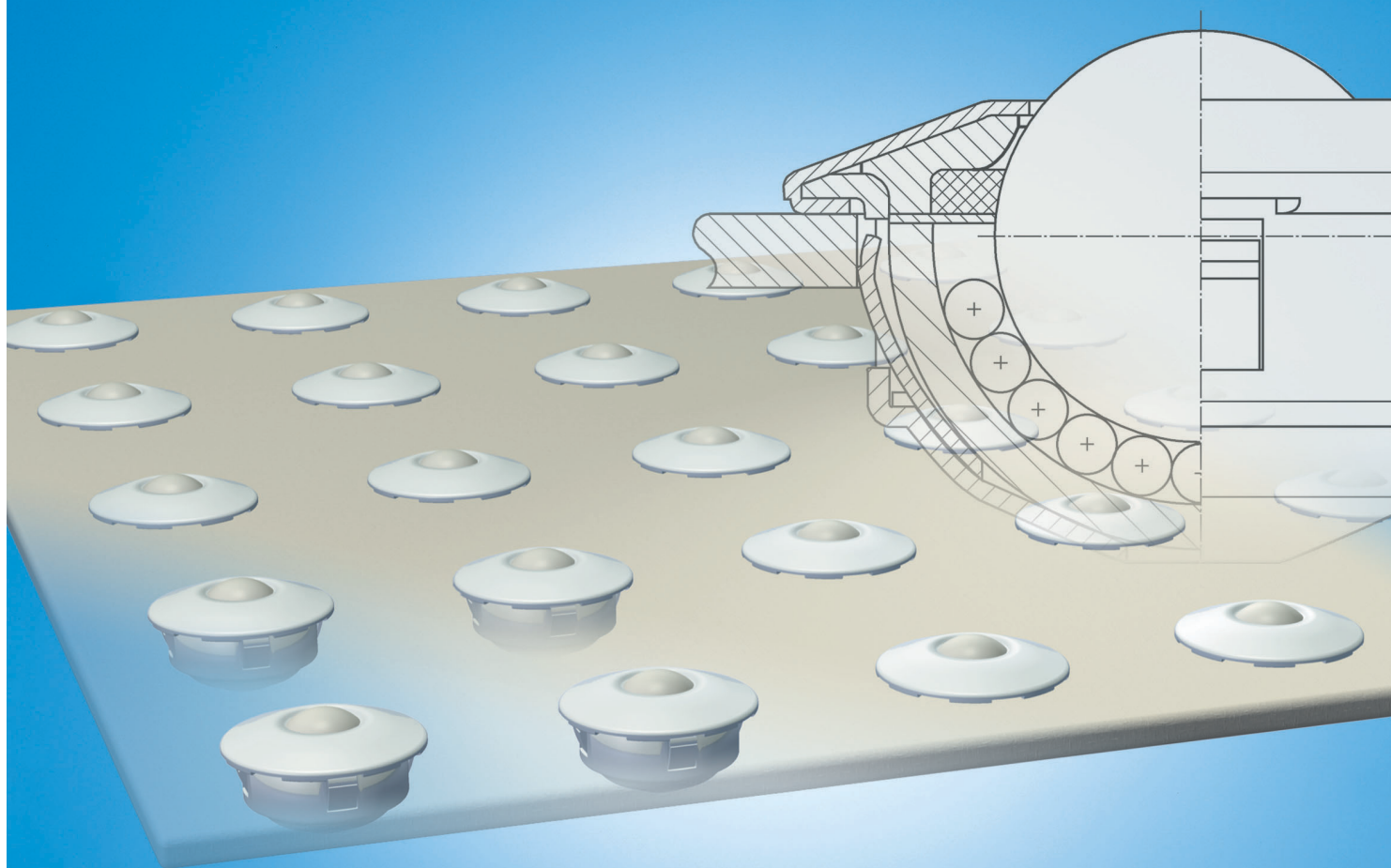

# Rexroth Linear Motion Technology

## Ball Rail Systems

Standard Ball Rail Systems  
Super Ball Rail Systems  
Ball Rail Systems with Aluminum Runner Blocks  
High-Speed Ball Rail Systems  
Corrosion-Resistant Ball Rail Systems  
Wide Ball Rail Systems

Ball Rail Systems with Integrated Measuring System  
Clamping and Braking Units for Ball Rail Systems  
Rack and Pinion for Ball Rail Systems  
Miniature Ball Rail Systems  
Cam Roller Guides

## Roller Rail Systems

Standard Roller Rail Systems  
Wide Roller Rail Systems  
Heavy Duty Roller Rail Systems  
Roller Rail Systems with Integrated Measuring System  
Clamping and Braking Units for Roller Rail Systems  
Rack and Pinion for Roller Rail Systems

## Linear Bushings and Shafts

Linear Bushings, Linear Sets  
Shafts, Shaft Support Rails, Shaft Support Blocks  
Ball Transfer Units  
Traditional Engineering Components

## Screw Drives

### Linear Motion Systems

Linear Motion Slides	<ul style="list-style-type: none"><li>– Ball Screw Drive</li><li>– Toothed Belt Drive</li></ul>
Linear Modules	<ul style="list-style-type: none"><li>– Ball Screw Drive</li><li>– Toothed Belt Drive</li><li>– Rack and Pinion Drive</li><li>– Pneumatic Drive</li><li>– Linear Motor</li></ul>
Compact Modules	<ul style="list-style-type: none"><li>– Ball Screw Drive</li><li>– Toothed Belt Drive</li><li>– Linear Motor</li></ul>
Precision Modules	<ul style="list-style-type: none"><li>– Ball Screw Drive</li></ul>
Ball Rail Tables	<ul style="list-style-type: none"><li>– Ball Screw Drive</li><li>– Linear Motor</li></ul>

Controllers, Motors, Electrical Accessories  
Linear Actuators

# Ball Transfer Units

<b>Product Overview</b>		<b>4</b>
<b>Technical Data</b>		<b>6</b>
<b>Tables</b>		<b>10</b>
Ball Transfer Units with Sheet Steel Housing	0530—...	10
Ball Transfer Units with Plastic Load Ball	0531—...	10
Ball Transfer Units, Spring-Loaded	0532—...	11
Ball Transfer Units with Solid Steel Housing	0533—...	12
Ball Transfer Units without Housing	0534—...	15
Ball Transfer Units with Reinforced Sheet Steel Housing	0535—...	15
Ball Transfer Units with Spring Clip	0536—...	16
Ball Transfer Units with Plastic Housing	0530—...	17
<b>Tolerance Ring/Mounting Tools</b>		<b>18</b>

# Ball Transfer Units

## Product Overview

Ball Transfer Units make light work of shifting, rotating and directing unit loads. They have proven extremely valuable as integral parts of conveyor systems, feed devices, and machining and packaging equipment.

### Applications

#### General-Purpose Machines

- Feed tables for sheet-metal working machines
- Fixtures for press brakes
- Feed devices for machining centers
- Drilling machine tables and motor-driven supporting tables
- Assembly aids in the manufacture of large engines and motors

#### Materials-Handling Systems

- Transfer ball tables, turntables and switches for sorting and distribution systems
- Crossover sections of continuous conveyors
- Baggage sorting systems at airports
- Transport of steel tubes and pipes
- Lifting platforms

#### Other Fields

- Construction of special-purpose machines
- Aerospace industry
- Nuclear reactors
- Beverage and stone-processing industries

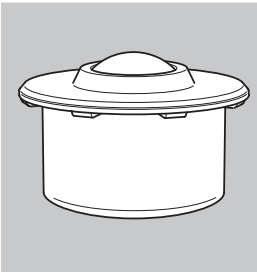
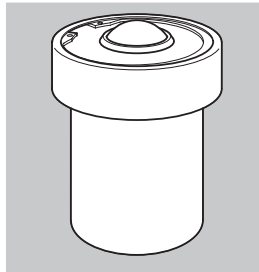
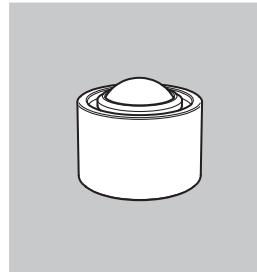
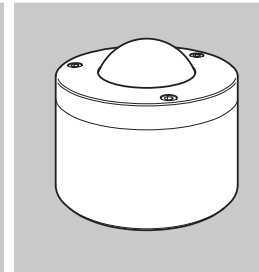
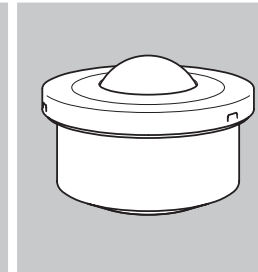
Ball Transfer Units				
				
<p><b>with sheet steel housing</b> 0530-...</p> <ul style="list-style-type: none"> <li>• smallest ball transfer unit</li> <li>• for general applications</li> </ul> <p><b>with plastic load ball</b> 0531-...</p> <ul style="list-style-type: none"> <li>• suitable particularly for transporting sensitive materials such as glass, polished aluminum, brass and steel sheets</li> </ul>	<p><b>spring-loaded</b> 0532-...</p> <ul style="list-style-type: none"> <li>• supported on springs and mounted under preload in a housing</li> <li>• Ball Transfer Unit recedes into its housing when overloaded</li> </ul>	<p><b>with steel housing</b> 0533-...</p> <ul style="list-style-type: none"> <li>• solid steel housing</li> <li>• without felt seal</li> <li>• very smooth movement</li> </ul>	<p><b>with steel housing</b> 0533-...</p> <ul style="list-style-type: none"> <li>• solid steel housing and cover</li> <li>• for very high loads</li> </ul>	<p><b>with steel housing</b> 0533-...</p> <ul style="list-style-type: none"> <li>• solid steel housing</li> <li>• for heavy loads</li> </ul>

▶ Easy mounting and extraction

▶ Types for all standard applications and for many special solutions

▶ Precise rolling and full load-bearing capability in any mounting orientation

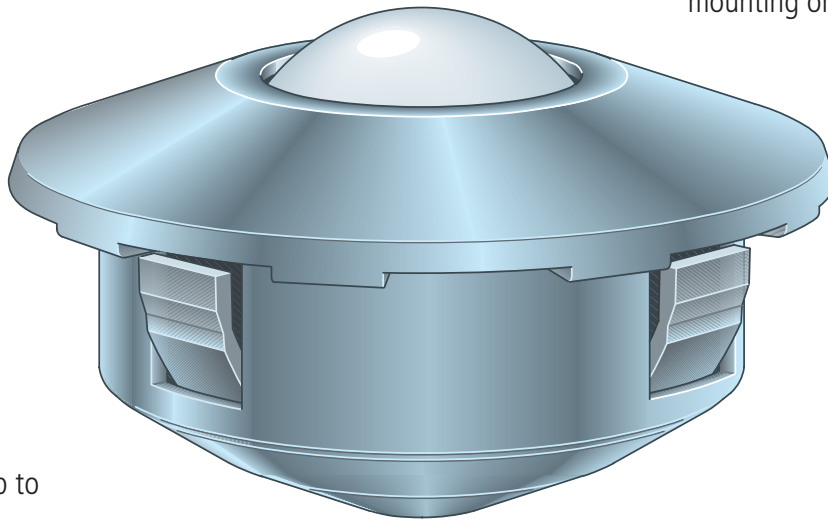

▶ Smooth running

▶ Conveying speed up to 2 m/sec in all types

▶ High rationalization effect

▶ Consistently high quality

### Ball Transfer Units

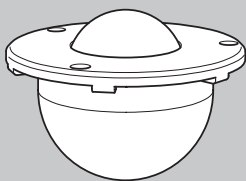

**without housing  
0534-...**

- low space requirement
- simple mounting
- mounting via holes in the collar

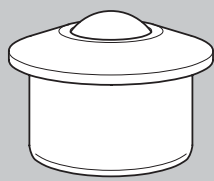

**with sheet steel housing  
0535-...**

- reinforced housing and cover
- for heavy impact loads

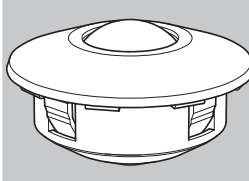

**with spring clip  
0536-...**

- easily mountable and extractable from the load side. Fixing is by means of spring clips, which permit generous tolerances in the mounting hole
- reinforced cover to withstand heavy impact loads

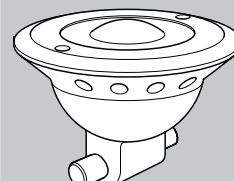

**with plastic housing  
0530-005-20**

- for special applications

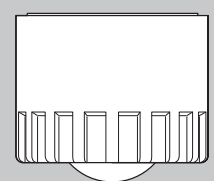

**with plastic housing  
0535-003-10**

- especially suited for overhead installation
- ball recedes totally into housing

# Ball Transfer Units

## Technical Data

### Structural design of the Ball Transfer Units

Ball Transfer Units have a steel housing incorporating a hardened ball cup.

The latter serves as a raceway for a multitude of small supporting balls.

The supporting balls roll against the ball cup when the load ball turns.

Ball Transfer Units are designed so that precise rolling and full load-bearing capability are ensured in any mounting orientation.

Ball Transfer Units require little maintenance, and almost every type is protected against dirt by an oil-soaked felt seal.

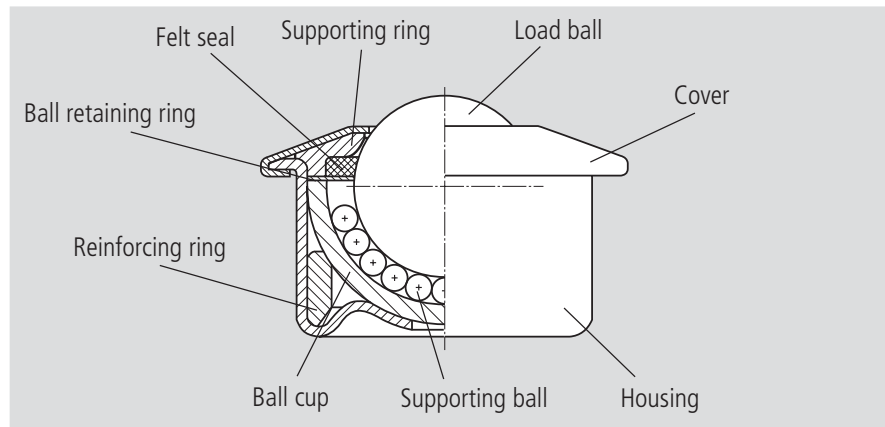

### Ball Transfer Units in corrosion-preventive design

Corrosion, caused by moisture or chemical attack, can lead to impaired functioning or even failure of the Ball Transfer Units.

Coated (galvanized + chromated) surfaces similar to DIN 50902 and DIN 50961 and/or higher-grade materials offer enhanced anticorrosion protection.

### Galvanized covers and housings

offer simple protection against corrosion. In this type, the supporting balls and load balls are made from standard antifriction

bearing steel and are protected from corrosive attack by the lubricant.

### Galvanized internals, corrosion-resistant steel balls

Consistent coating of all internals and the use of corrosion-resistant steels for the antifriction bearing elements, similar to

ISO 683-17, ensures comprehensive corrosion protection such as specified in ASTM B117-97.

### All parts made from rust and acid resistant steel (Antifriction bearing steel to EN 10 088)

This type is selected if the conveyed articles are abrasive and/or there is exposure to an aggressive environment, especially to chemicals.

Since all versions have been designed to meet the high standards of ISO 281, even this type is unsuitable for underwater use.

## Mounting possibilities

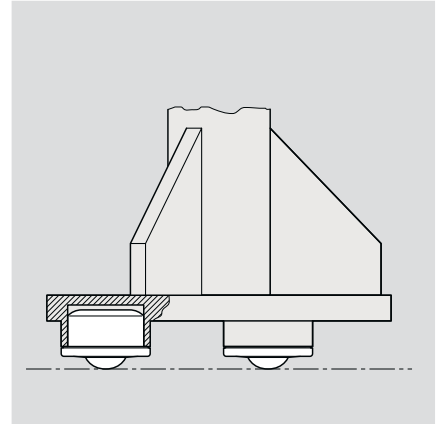
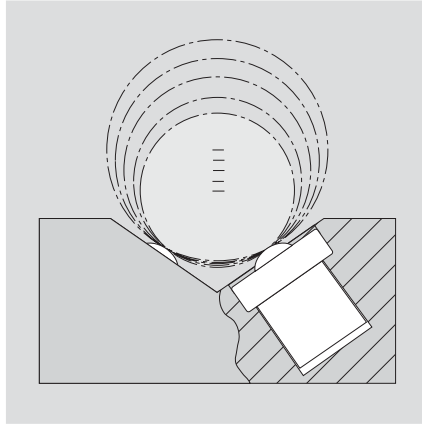
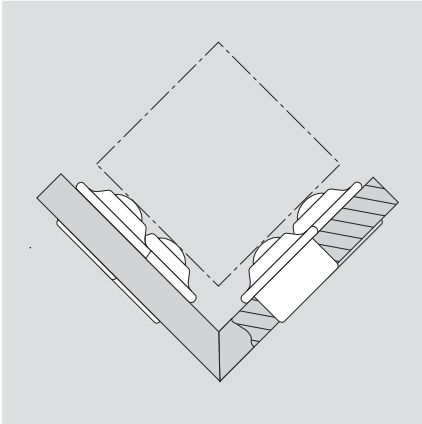

## Application example

Ball Transfer Units used for assembling ball rail system runner blocks

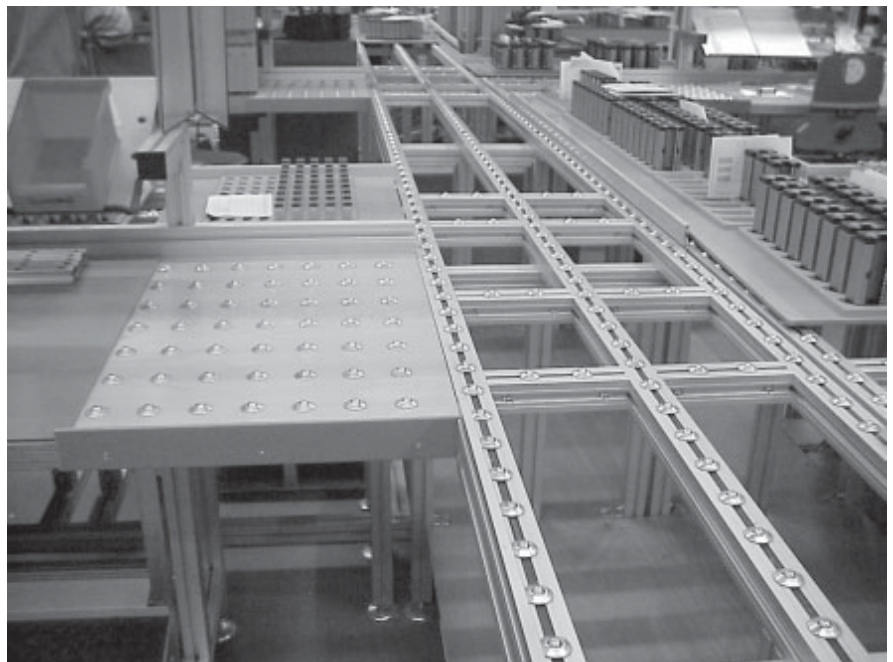

# Ball Transfer Units

## Technical Data

### Arrangement of the Ball Transfer Units

How the Ball Transfer Units should be arranged depends on the undersurface of the conveyed article. For articles with a uniform, smooth undersurface, such as boxes and cases, the distance between the Ball Transfer Units is calculated simply by dividing the smallest edge length by 2.5.

Example:

Undersurface of the conveyed article  
= 500 x 1000 mm

Distance between Ball Transfer Units

$$a = \frac{500 \text{ mm}}{2.5} = 200 \text{ mm}$$

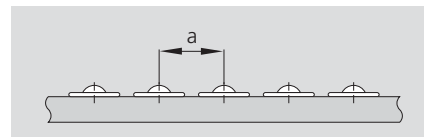

### Determining the load for Ball Transfer Units

To determine the load for a Ball Transfer Unit, the mass of the conveyed article is divided by 3.

If the load ball height tolerances are well-correlated, it is possible, depending on the nature of the conveyed article, to also perform the calculation based on the number of load-bearing Ball Transfer Units.

Example:

Mass = 3000 N

Ball Transfer Unit load

$$F = \frac{3000 \text{ N}}{3} = 1000 \text{ N}$$

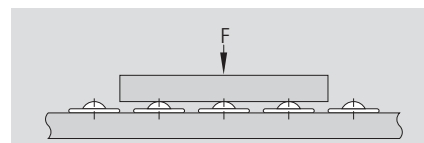

### Spring-loaded Ball Transfer Units

The figures in the column headed "Preload" are most important when choosing the size for these types. The mass of the conveyed article is divided in this case by the number of load-bearing Ball Transfer Units.

### Conveying speed

$$V_{\max} = 2 \text{ m/sec}$$

### Load capacity

The stated load capacities apply to all mounting orientations and relate to  $10^6$  rotations of the load ball. In case of prolonged periods of use at speeds above 1 m/sec, an increase in temperature and reduced nominal life must be expected as a function of the load, especially for sizes 60 to 90.

### Calculation of the nominal life

$L = \left(\frac{C}{F}\right)^3 \cdot 10^6$	L = Nominal life (rotations) C = Load capacity [N] F = Load [N]
---	---

### Friction coefficients

The diagram shows the friction coefficients of Ball Transfer Units as a function of load and speed. These guideline values apply to any mounting orientation for rolling contact on a hardened steel plate.

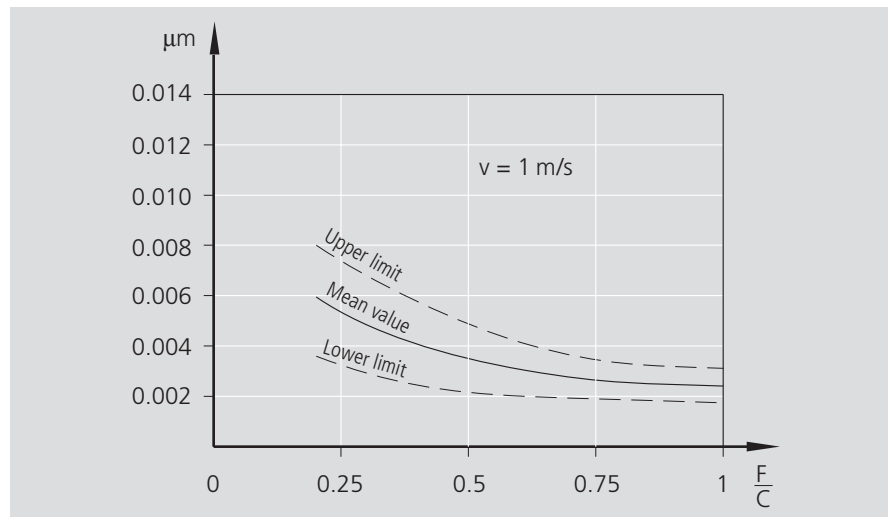

### Operating temperature

Ball Transfer Unit with steel load ball:

up to 100 °C.  
 At temperatures above 100 °C, only non-galvanized load balls without a felt seal should be used.  
 Make allowance for reduction in load capacity.

Use high-temperature lubricant!  
 Observe the manufacturer's instructions!

The existing lube oil may have to be washed out.

Ball Transfer Unit with plastic load ball:

up to 30 °C.  
 At temperatures above 30 °C, make allowance for reduction in load capacity.

### Temperature factor

for steel load ball:

Temperature °C	Temperature factor $f_T$
125	0.9
150	0.8
175	0.7
200	0.5

for plastic load ball:

Temperature °C	Temperature factor $f_T$
40	0.9
50	0.8
60	0.7
80	0.5

The load capacity must be multiplied by the temperature factor.

### Lubrication

The lubrication must be adapted to the conveyed articles and to the ambient conditions. The lubricant (oil) can be introduced via the load ball.

# Ball Transfer Units Tables

## Ball Transfer Units with Sheet Steel Housing

### 0530 – ...

- for general applications

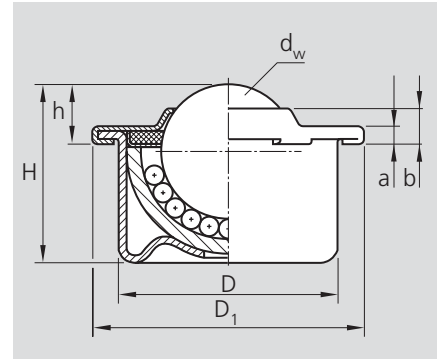
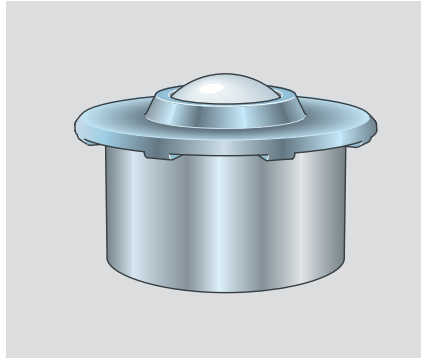

Part numbers	Execution	Dimensions [mm]							Load capacity C [N]	Mass [kg]
		d <sub>w</sub>	D	D <sub>1</sub>	h	H	a	b		
0530-108-10 <sup>1)*</sup>	Cover and housing galvanized	8	12.6 ± 0.055	17	4.8 ± 0.15	11.2	1.8	3.2	100	0.007
0530-112-10 <sup>1)*</sup>		12	18.0 ± 0.055	23	7.4 ± 0.15	15.5	2.0	4.3	250	0.018
0530-115-10 <sup>1)</sup>		15	24.0 ± 0.065	31	9.5 ± 0.20	21.5	2.5	6.1	500	0.038
0530-122-10 <sup>2)</sup>		22	36.0 ± 0.080	45	9.8 ± 0.20	29.5	2.9	5.7	1300	0.132
0530-130-10 <sup>2)</sup>		30	45.0 ± 0.080	55	13.8 ± 0.30	37.5	3.7	7.9	2500	0.265
0530-145-10 <sup>2)</sup>	45	62.0 ± 0.095	75	19.0 ± 0.40	53.7	4.2	10.3	6000	0.720	
0530-208-10 <sup>1)*</sup>	All parts galvanized, balls made from corrosion-resistant steel	8	12.6 ± 0.055	17	4.8 ± 0.15	11.2	1.8	3.2	70	0.007
0530-212-10 <sup>1)*</sup>		12	18.0 ± 0.055	23	7.4 ± 0.15	15.5	2.0	4.3	180	0.018
0530-215-10 <sup>1)</sup>		15	24.0 ± 0.065	31	9.5 ± 0.20	21.5	2.5	6.1	370	0.038
0530-222-10 <sup>2)</sup>		22	36.0 ± 0.080	45	9.8 ± 0.20	29.5	2.9	5.7	970	0.132
0530-230-10 <sup>2)</sup>		30	45.0 ± 0.080	55	13.8 ± 0.30	37.5	3.7	7.9	1900	0.265
0530-245-10 <sup>2)</sup>	45	62.0 ± 0.095	75	19.0 ± 0.40	53.7	4.2	10.3	4500	0.720	
0530-608-00 <sup>1)*</sup>	All parts made from corrosion-resistant steel	8	12.6 ± 0.055	17	4.8 ± 0.15	11.2	1.8	3.2	70	0.007
0530-612-00 <sup>1)*</sup>		12	18.0 ± 0.055	23	7.4 ± 0.15	15.5	2.0	4.3	180	0.018
0530-615-00 <sup>1)</sup>		15	24.0 ± 0.065	31	9.5 ± 0.20	21.5	2.5	6.1	370	0.038
0530-622-00 <sup>2)</sup>		22	36.0 ± 0.080	45	9.8 ± 0.20	29.5	2.9	5.7	970	0.132
0530-630-00 <sup>2)</sup>		30	45.0 ± 0.080	55	13.8 ± 0.30	37.5	3.7	7.9	1900	0.265

## Ball Transfer Units with Plastic Load

### Ball 0531 – ...

- suitable for conveying sensitive articles

Part numbers	Execution	Dimensions [mm]							Load capacity <sup>4)</sup> C [N]	Mass [kg]
		d <sub>w</sub>	D	D <sub>1</sub>	h	H	a	b		
0531-108-10 <sup>1)*</sup>	Cover and housing galvanized	8	12.6 ± 0.055	17	4.8 ± 0.15	11.2	1.8	3.2	10	0.005
0531-112-10 <sup>1)*</sup>		12	18.0 ± 0.055	23	7.4 ± 0.15	15.5	2.0	4.3	35	0.012
0531-115-10 <sup>1)</sup>		15	24.0 ± 0.065	31	9.5 ± 0.20	21.5	2.5	6.1	70	0.024
0531-122-10 <sup>3)</sup>		22	36.0 ± 0.080	45	9.6 ± 0.20	29.3	2.9	5.7	100	0.093
0531-130-10 <sup>3)</sup>		30	45.0 ± 0.080	55	13.6 ± 0.30	37.3	3.7	7.9	150	0.168
0531-208-10 <sup>1)*</sup>	All parts galvanized, load balls made from corrosion-resistant steel	8	12.6 ± 0.055	17	4.8 ± 0.15	11.2	1.8	3.2	10	0.005
0531-212-10 <sup>1)*</sup>		12	18.0 ± 0.055	23	7.4 ± 0.15	15.5	2.0	4.3	35	0.012
0531-215-10 <sup>1)</sup>		15	24.0 ± 0.065	31	9.5 ± 0.20	21.5	2.5	6.1	70	0.024
0531-222-10 <sup>3)</sup>		22	36.0 ± 0.080	45	9.6 ± 0.20	29.3	2.9	5.7	100	0.093
0531-230-10 <sup>3)</sup>		30	45.0 ± 0.080	55	13.6 ± 0.30	37.3	3.7	7.9	150	0.168
0531-608-00 <sup>1)*</sup>	All parts made from corrosion-resistant steel	8	12.6 ± 0.055	17	4.8 ± 0.15	11.2	1.8	3.2	10	0.005
0531-612-00 <sup>1)*</sup>		12	18.0 ± 0.055	23	7.4 ± 0.15	15.5	2.0	4.3	35	0.012
0531-615-00 <sup>1)</sup>		15	24.0 ± 0.065	31	9.5 ± 0.20	21.5	2.5	6.1	70	0.024
0531-622-00 <sup>3)</sup>		22	36.0 ± 0.080	45	9.6 ± 0.20	29.3	2.9	5.7	100	0.093
0531-630-00 <sup>3)</sup>		30	45.0 ± 0.080	55	13.6 ± 0.30	37.3	3.7	7.9	150	0.168

<sup>1)</sup> Without felt seal   <sup>2)</sup> Bottom holes for dirt discharge against surcharge   <sup>3)</sup> Dry felt seal   <sup>4)</sup> At 20 °C   <sup>\*)</sup> Available as of October 2003

## Spring-loaded Ball Transfer Units

### 0532 – ...

- supported on springs and mounted under preload in a housing
- Ball Transfer Unit recedes into its housing when overloaded

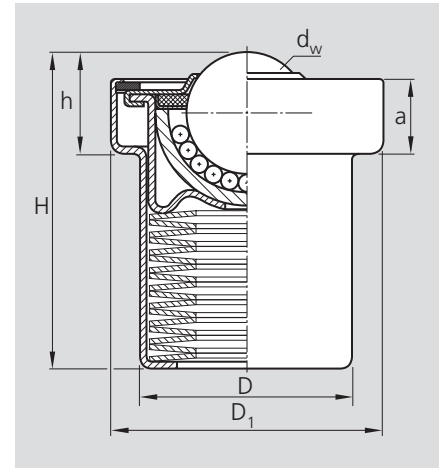
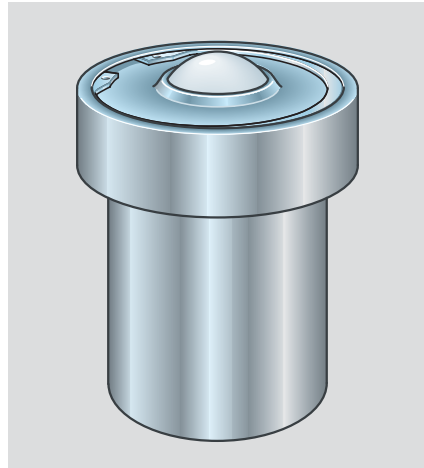

Part numbers	Execution	Dimensions [mm]						Pre-load [N]	Ulti- mate load <sup>1)</sup> [N]	Tol. for pre- load and ult. load [%]	Mass [kg]
		d <sub>w</sub>	D	D <sub>1</sub>	h	H	a				
0532-122-10	Cover and housing galvanized	22	38.8	50 ± 0.100	18.6	58.1	13.6	730	860	+25/-7.5	0.30
0532-130-10		30	48.2	62 ± 0.125	24.4	70.0	17.0	1350	1600	+15/-7.5	0.60
0532-145-10		45	66.4	85 ± 0.150	35.6	100.5	24.2	2280	2770	+15/-7.5	1.60
0532-222-10	All parts galvanized, balls made from cor- rosion-resistant steel	22	38.8	50 ± 0.100	18.6	58.1	13.6	730	860	+25/-7.5	0.30
0532-230-10		30	48.2	62 ± 0.125	24.4	70.0	17.0	1350	1600	+15/-7.5	0.60
0532-245-10		45	66.4	85 ± 0.150	35.6	100.5	24.2	2280	2770	+15/-7.5	1.60
0532-123-10 <sup>2)</sup>	Galvanized	22	38.8	50 ± 0.100	18.6	58.1	13.6	170	250	+15/-7.5	0.28

<sup>1)</sup> Under ultimate load the Ball Transfer Unit recedes completely.

<sup>2)</sup> With helical spring

# Ball Transfer Units Tables

## Ball Transfer Units with Solid Steel Housing – without collar –

0533 – ...

- without felt seal
- very smooth movement

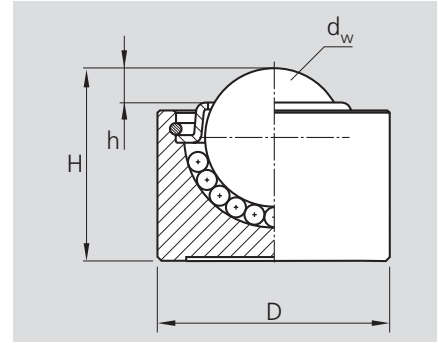
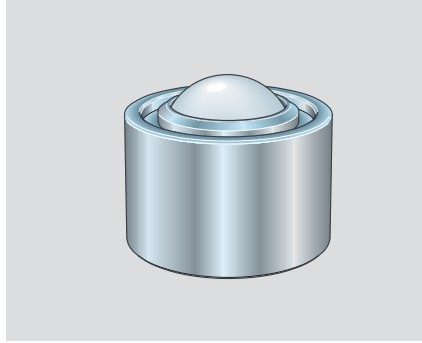

Part number	Execution	Dimensions [mm]				Load capacity C [N]	Mass [kg]
		d <sub>w</sub>	D	h	H		
0533-712-00	Bright metal	12	20 ± 0.065	~3	16.5 ± 0.2	250	0.028

## Ball Transfer Units with Solid Steel Housing – without high collar –

0533 – ...

- without felt seal
- very smooth movement
- recedes partially into housing

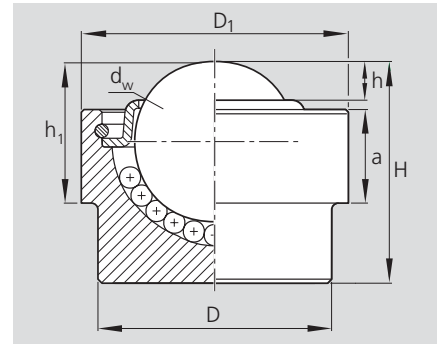
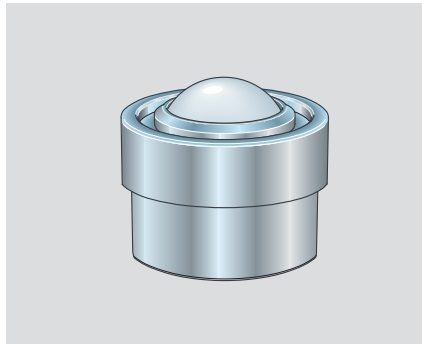

Part number	Execution	Dimensions [mm]						Load capacity C [N]	Mass [kg]	
		d <sub>w</sub>	D	D <sub>1</sub>	h	h <sub>1</sub>	H			a
0533-702-00	Bright metal	12	17.5 ± 0.1	20 ± 0.1	~3	10.5 ± 0.1	16.5 ± 0.2	7 ± 0.1	250	0.027

## Ball Transfer Units with Solid Steel Housing – with low collar –

0533 – ...

- without felt seal
- very smooth movement
- recedes totally into housing

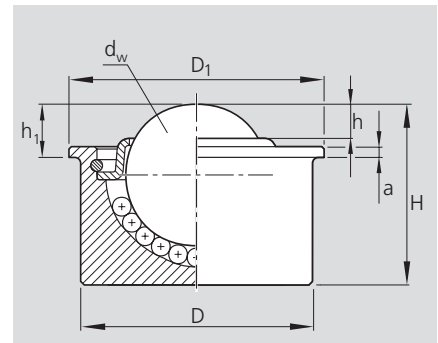
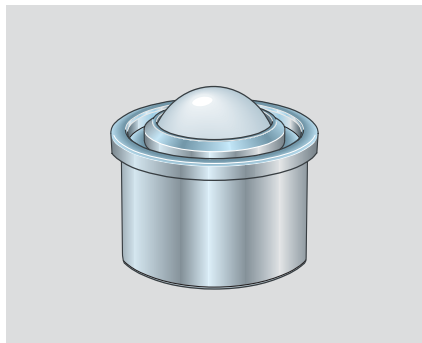

Part number	Execution	Dimensions [mm]						Load capacity C [N]	Mass [kg]	
		d <sub>w</sub>	D	D <sub>1</sub>	h	h <sub>1</sub>	H			a
0533-012-00	Bright metal	12	20 ± 0.065	22 - 0.5	~3	4.5 ± 0.1	15	1	250	0.024

**Ball Transfer Units with Solid Steel Housing – with collar – (with felt seal)**

0533 – ...

- for high loads

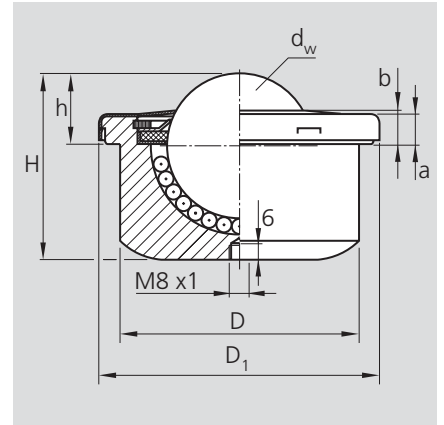
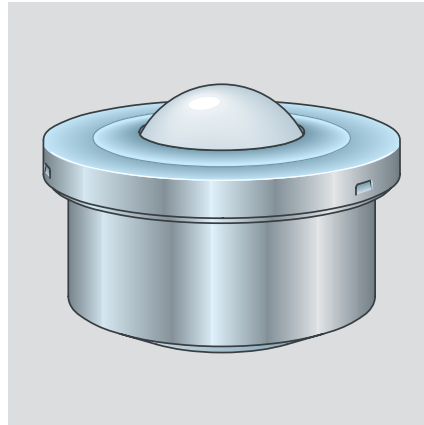

Part numbers	Execution <sup>1)</sup>	Dimensions [mm]							Load capacity C [N]	Mass [kg]
		d <sub>w</sub>	D	D <sub>1</sub>	h	H	a	b		
0533-060-00	Bright metal	60	100 ± 0.11	117	29.5 ± 0.2	77.5	13	14.5	13000	3.5
0533-160-10	Cover and housing galvanized	60	100 ± 0.11	117	29.5 ± 0.2	77.5	13	14.5	13000	3.5
0533-260-10	All parts galvanized, balls made from corrosion-resistant steel	60	100 ± 0.11	117	29.5 ± 0.2	77.5	13	14.5	9700	3.5

<sup>1)</sup> Upon request, available with lube hole (0533-x61-x0)

**Ball Transfer Units with Solid Steel Housing – with collar –**

0533 – ...

- plastic seal for heavy soiling
- for high loads

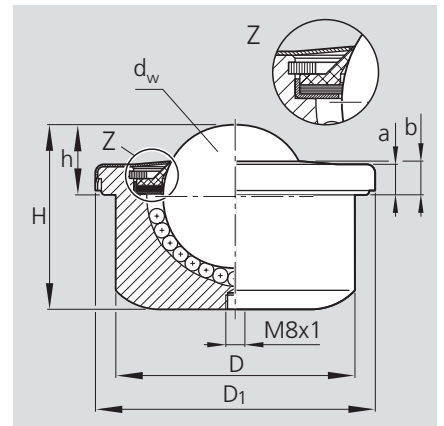
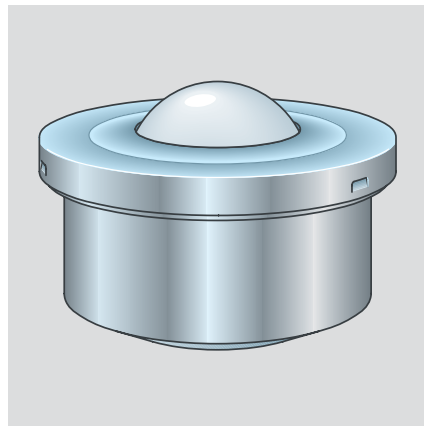

Part number	Execution	Dimensions [mm]							Load capacity C [N]	Mass [kg]
		d <sub>w</sub>	D	D <sub>1</sub>	h	H	a	b		
0533-105-10	Cover and housing galvanized	60	100 ± 0.11	117	29.5 ± 0.2	77.5	13	14.5	13000	3.5

# Ball Transfer Units Tables

## Ball Transfer Units with Solid Steel Housing – without collar –

0533 – ...

(with felt seal)

- for high loads

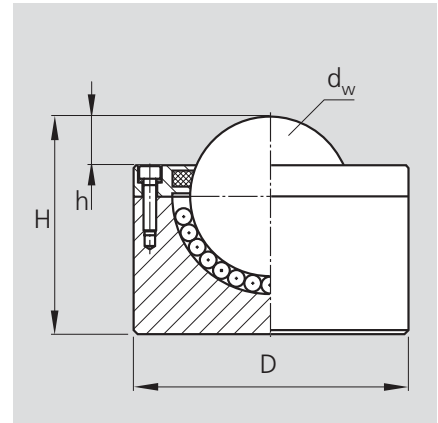
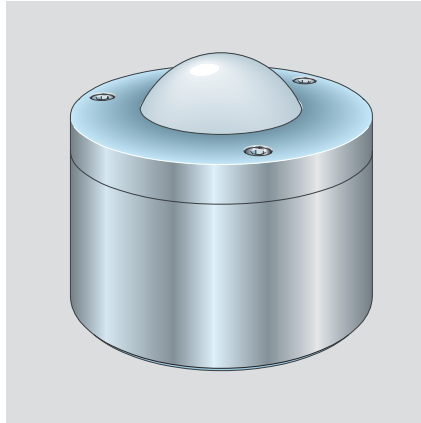

Part numbers	Execution	Dimensions [mm]				Load capacity C [N]	Mass [kg]
		d <sub>w</sub>	D	h	H		
0533-076-00 <sup>1)</sup>	Bright metal	76	130 ± 0.08	23	103 ± 0.2	20000	8.6
0533-090-00 <sup>2)</sup>		90	145 ± 0.08	25	115 ± 0.2	25000	11.0

<sup>1)</sup> Upon request, available with lube hole

<sup>2)</sup> Lube hole R1/8" (at center of base) closed by screw plug

## Ball Transfer Units with Solid Steel Housing – without collar –

0533 – ...

- for high loads
- relubrication bores
- plastic seal for heavy soiling
- mounting holes

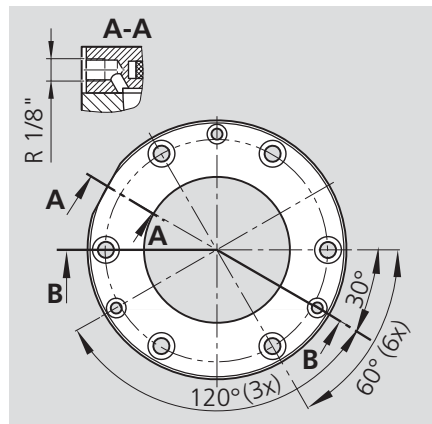
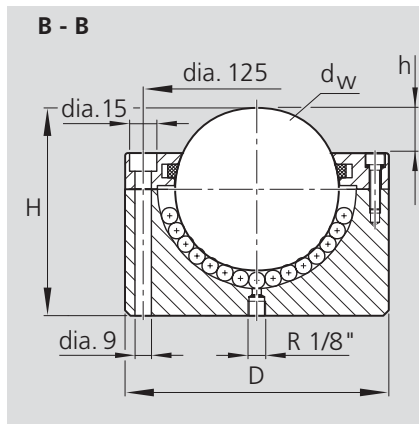
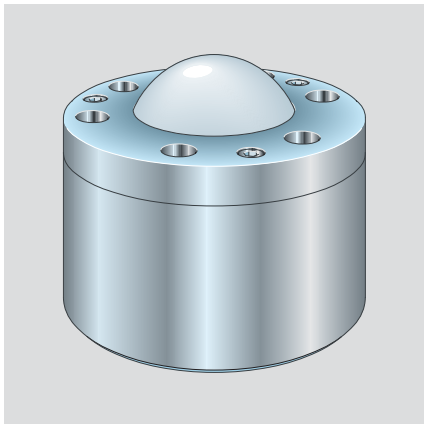

Part number	Execution	Dimensions [mm]				Load capacity C [N]	Mass [kg]
		d <sub>w</sub>	D	h	H		
0533-011-00	Bright metal	90	145 ± 0.08	25	115 ± 0.2	25000	11.0

## Ball Transfer Units without Housing

### 0534 – ...

- low space requirement
- simple mounting
- mounting via holes in the collar

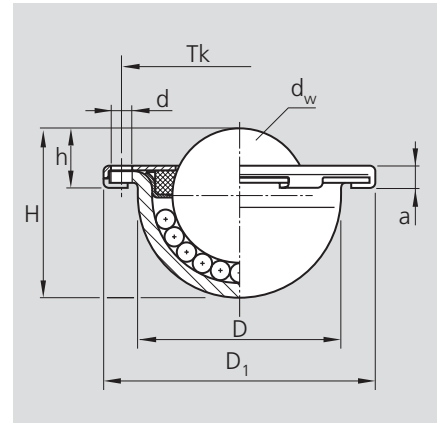
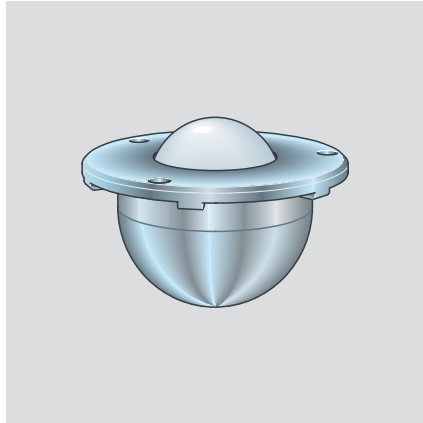

Part numbers	Execution	Dimensions [mm]						Mounting holes			Load capacity C [N]	Mass [kg]
		d <sub>w</sub>	D	D <sub>1</sub>	h	H	a	d	Tk	Number		
0534-122-10	Cover and ball cup galvanized	22	33 ± 0.2	45	9.8 ± 0.2	27.7	3.6	3.5	39	3	1200	0.1
0534-222-10	All parts galvanized, balls made from corrosion-resistant steel	22	33 ± 0.2	45	9.8 ± 0.2	27.7	3.6	3.5	39	3	900	0.1

## Ball Transfer Units with Reinforced Sheet Steel Housing

### 0535 – ...

- for extreme impact loads
- The special shape of the cover requires the use of a mounting tool, particularly if firmly lodged – see Mounting Tools.
- heavy duty version 0535-X47-10

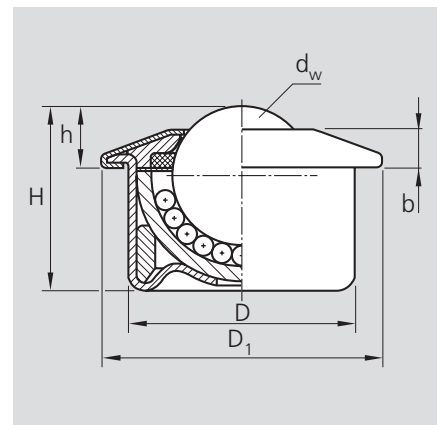
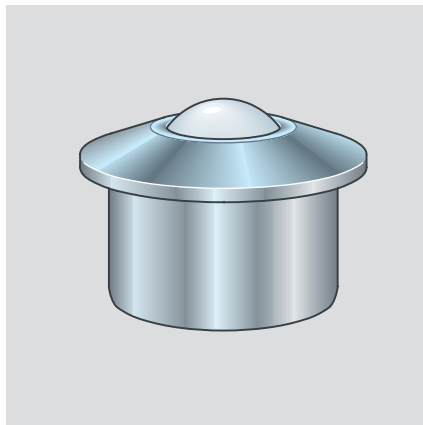

Part numbers	Execution	Dimensions [mm]						Load capacity C [N]	Mass [kg]
		d <sub>w</sub>	D	D <sub>1</sub>	h	H	b		
0535-115-10	Cover and housing galvanized	15	24 ± 0.065	31	9.5 ± 0.2	21.5	5.5	500	0.045
0535-122-10		22	36 ± 0.080	45	9.8 ± 0.2	29.5	6.0	1300	0.150
0535-130-10		30	45 ± 0.080	55	13.8 ± 0.3	37.5	8.0	2500	0.300
0535-145-10		45	62 ± 0.095	75	19.0 ± 0.4	53.7	10.0	6000	0.820
0535-147-10		45	62 ± 0.095	75	19.0 ± 0.4	53.7	10.0	8000	0.820
0535-215-10	All parts galvanized, balls made from hardened corrosion-resistant steel	15	24 ± 0.065	31	9.5 ± 0.2	21.5	5.5	370	0.045
0535-222-10		22	36 ± 0.080	45	9.8 ± 0.2	29.5	6.0	970	0.150
0535-230-10		30	45 ± 0.080	55	13.8 ± 0.3	37.5	8.0	1900	0.300
0535-245-10		45	62 ± 0.095	75	19.0 ± 0.4	53.7	10.0	4500	0.820
0535-247-10		45	62 ± 0.095	75	19.0 ± 0.4	53.7	10.0	6000	0.820
0535-331-10 <sup>1)</sup>	Ball cup, balls and ball retaining ring made from corrosion-resistant steel. Other parts galvanized.	30	45 ± 0.080	55	13.8 ± 0.3	37.5	8.0	1900	0.300

<sup>1)</sup> With holes in base for dirt discharge

# Ball Transfer Units Tables

## Ball Transfer Units with Spring Clip

### 0536 – ...

- easily mountable and extractable from the load side. Fixing is by means of spring clips, which permit generous tolerances in the mounting hole.
- reinforced cover to withstand heavy impact loads
- types with plastic load ball
- The special cover shape requires use of mounting tool – see Mounting Tools.

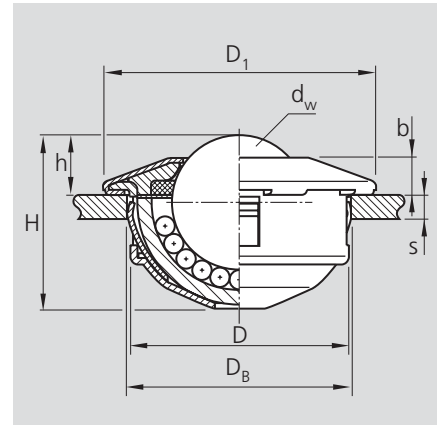
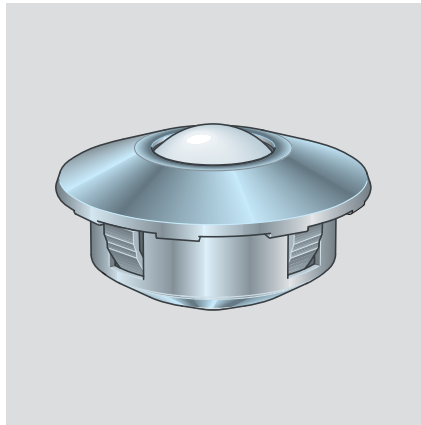

Part numbers	Execution	Dimensions [mm]							Mounting cutout dia. D <sub>B</sub>	s <sup>1)</sup> min	Load capacity C [N]	Mass [kg]
		d <sub>w</sub>	D	D <sub>1</sub>	h	H	b					
0536-115-10	Cover and housing galvanized	15	24 - 0.13	31	9.5 ± 0.2	20.5	5.5	24 + 0.5	1.5	500	0.044	
0536-122-10		22	36 - 0.16	45	9.8 ± 0.2	28.6	6.0	36 + 0.8	2.0	1300	0.146	
0536-130-10		30	45 - 0.16	55	13.8 ± 0.3	37.5	8.0	45 + 1.0	2.5	2500	0.290	
0536-215-10	All parts galvanized, balls made from corrosion-resistant steel	15	24 - 0.13	31	9.5 ± 0.2	20.5	5.5	24 + 0.5	1.5	370	0.044	
0536-222-10		22	36 - 0.16	45	9.8 ± 0.2	28.6	6.0	36 + 0.8	2.0	970	0.146	
0536-230-10		30	45 - 0.16	55	13.8 ± 0.3	37.5	8.0	45 + 1.0	2.5	1900	0.290	
0536-331-10 <sup>2)</sup>		30	45 - 0.16	55	13.8 ± 0.3	37.5	8.0	45 + 1.0	2.5	1900	0.290	
0536-415-10	Cover and housing galvanized, with plastic load ball	15	24 - 0.13	31	9.5 ± 0.2	20.5	5.5	24 + 0.5	1.5	70	0.044	
0536-422-10		22	36 - 0.16	45	9.8 ± 0.2	28.6	6.0	36 + 0.8	2.0	100	0.146	
0536-430-10		30	45 - 0.16	55	13.8 ± 0.3	37.5	8.0	45 + 1.0	2.5	150	0.290	

<sup>1)</sup> Minimum nominal thickness of mounting base

<sup>2)</sup> With holes in base for dirt discharge

### Ball Transfer Units with Plastic Housing

0530 – ...

- for lightweight ball transfer tables

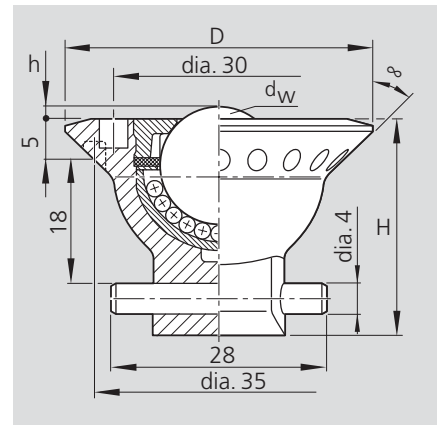

Part number	Execution	Dimensions [mm]				Load capacity C [N]	Mass [kg]
		$d_w$	D	h	H		
0530-005-20	Mounting with quarter-turn fastener	15	42	2	32	500	0.045

### Ball Transfer Units with Plastic Housing

0530 – ...

- especially suited for overhead installation
- ball recedes totally into housing

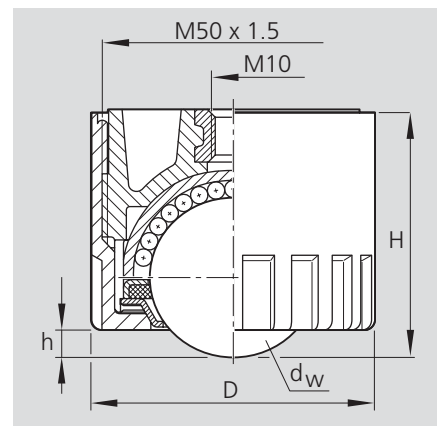

Part number	Execution	Dimensions [mm]				Load capacity C [N]	Mass [kg]
		$d_w$	D	h	H		
0530-003-10	Height-adjustable, mounting with threaded bushing	30	54	5	46	2500	0.264

# Ball Transfer Units

## Tolerance Ring / Mounting Tools

### Tolerance Ring

0810 – ...

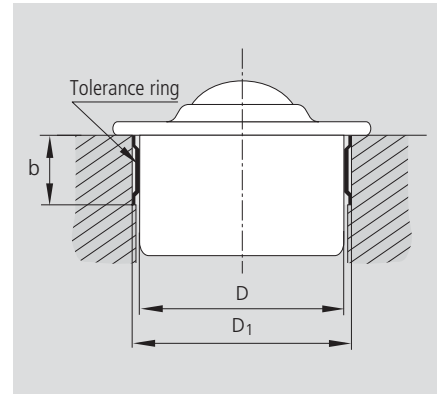
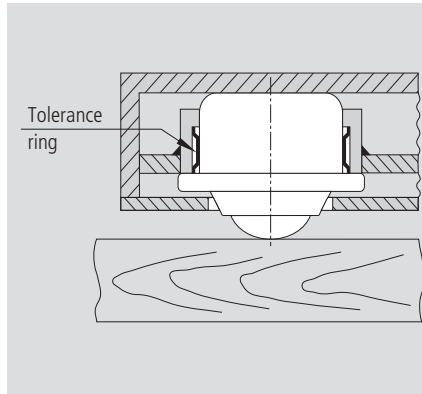

Ball Transfer Unit Part numbers			Dimensions [mm] D	Tolerance ring Part numbers	Mounting dimensions [mm] D <sub>1</sub> b		
0530–.15–..	0531–.15–..	—	0535–.15–..	24	0810–024–03	25.7 + 0.20	7.1 <sup>+0.2</sup>
0530–.22–..	0531–.22–..	—	0535–.22–..	36	0810–036–05	37.7 + 0.20	12.1 <sup>+0.2</sup>
0530–.30–..	0531–.30–..	—	0535–.30–..	45	0810–045–01	46.7 + 0.20	12.1 <sup>+0.2</sup>
0530–.45–..	—	—	0535–.4–..	62	0810–062–03	64.1 + 0.30	15.1 <sup>+0.2</sup>
—	—	0533–.60–..	—	100	0810–100–02	102.5 + 0.35	19.1 <sup>+0.3</sup>

### Mounting Tool 0536

for Ball Transfer Units 0535– and 0536–

for d <sub>w</sub>	Part numbers	Dimensions [mm]			a [°]
		D <sub>2</sub>	D <sub>3</sub>	t <sub>min</sub>	
15	0536–015–30	29	17	10	30
22	0536–022–30	43	24	10	20
30	0536–030–30	53	30	10	24
45	0536–045–30	73	45	15	26

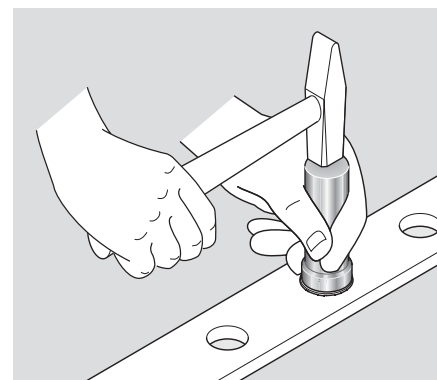
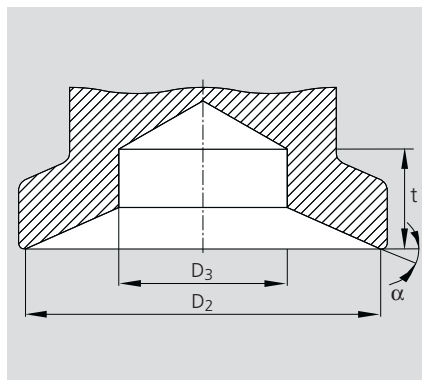

### Extraction Tool

Recommended for Ball Transfer Units 0536–

for d <sub>w</sub>	Dimensions [mm]	
	H <sup>1)</sup> max	B <sup>1)</sup> max
15	0.6	6
22	0.6	8
30	0.8	10

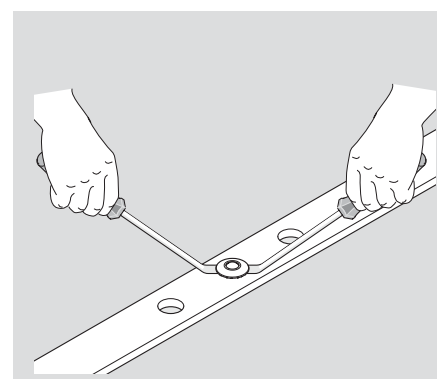
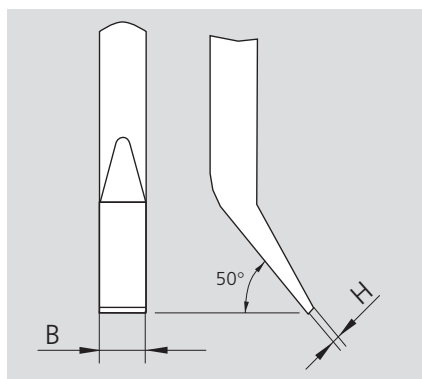

<sup>1)</sup> Suitable for the recesses in the collar of the Ball Transfer Unit 0536–

# Sketch

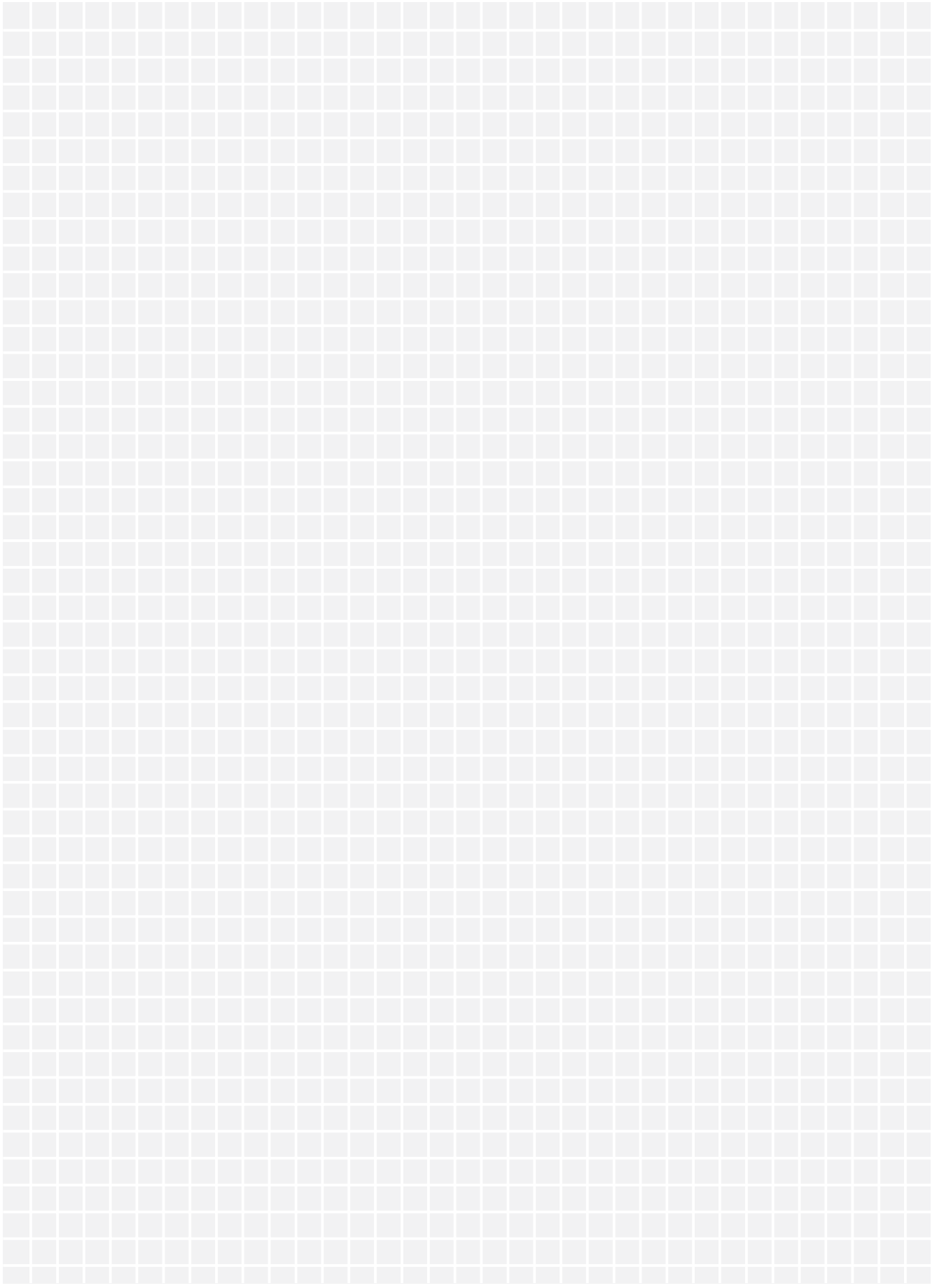

Bosch Rexroth Corporation  
Linear Motion and  
Assembly Technologies  
14001 South Lakes Drive  
Charlotte, NC 28273  
Telephone (800) 438-5983  
Facsimile (704) 583-0523  
[www.boschrexroth-us.com](http://www.boschrexroth-us.com)

Bosch Rexroth Corporation  
Corporate Headquarters  
5150 Prairie Stone Parkway  
Hoffman Estates, IL 60192-3707  
Telephone (847) 645-3600  
Facsimile (847) 645-6201

Bosch Rexroth Corporation  
Industrial Hydraulics  
2315 City Line Road  
Bethlehem, PA 18017-2131  
Telephone (610) 694-8300  
Facsimile (610) 694-8467

Bosch Rexroth Corporation  
Electric Drives and Controls  
5150 Prairie Stone Parkway  
Hoffman Estates, IL 60192-3707  
Telephone (847) 645-3600  
Facsimile (847) 645-6201

Bosch Rexroth Corporation  
Pneumatics  
1953 Mercer Road  
Lexington, KY 40511-1021  
Telephone (859) 254-8031  
Facsimile (859) 281-3491

Bosch Rexroth Corporation  
Mobile Hydraulics  
1700 Old Mansfield Road  
Wooster, OH 44691-0394  
Telephone (330) 263-3300  
Facsimile (330) 263-3333