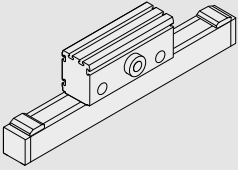
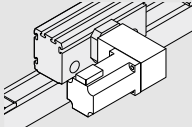
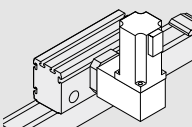
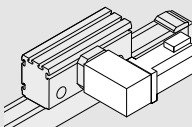
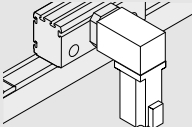
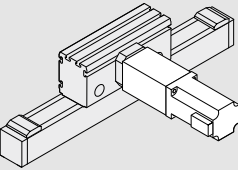

OBB 55

Components and Ordering Data

Part number, length R1144 100 00, mm		Guideway	Drive unit				Carriage	
Version			Reduction				$L_{ca} = 230 \text{ mm}$	$L_{ca} = 266 \text{ mm}$
							without	with
							Clamping unit	
			i = 1	i = 3	i = 5	i = 8		
With drive unit (MA), w/o gear reducer $i=1$	MA01 	01	Clamping shaft	01	-		01	02
With gear reducer (MG), angled gear reducer WPLE	MG01 	01	Angled gear reducer at left / at top / at right / at bottom	-	10		01	02
	MG02 			-	10			
	MG03 			-	10			
	MG04 			-	10			
With gear reducer (MG), straight gear reducer PLE	MG10 	01	Straight gear reducer at side	-	10		01	02

Ordering example: see "Inquiry/Order"

L_{ca} = carriage length

Please check whether the selected combination is a permissible one (load capacities, moments, maximum speeds, motor data, etc.)!

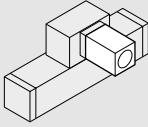
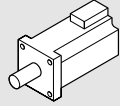
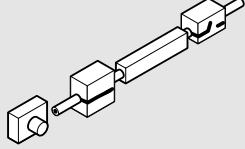
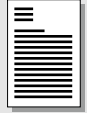
Motor attachment				Motor		Switches / Cable duct / Socket-plug		Documentation	
								Standard report	
Reduction i =	Attachment kit ¹⁾		for motor	without	with				
	MG01	MG02		Brake					
	MG03	MG04							
-	00		-	00		Without switch and cable duct 00			
						Carriage travels			
						Switches:			
						- PNP NC		71 ± ... mm	
						- PNP NO		73 ± ... mm	
						- Mechanical		75 ± ... mm	
						Ordering data:			
						Switch type			
						Travel direction			
						Switching distance			
						Cable duct – length		20 - ... mm	
						Socket-plug		17	
						One switching strip		36	
						Frame travels			
						Switches:			
						- PNP NC		61 ± ... mm	
						- PNP NO		63 ± ... mm	
						- Mechanical		65 ± ... mm	
						Socket-plug		17	
						One switching strip		38	
						Two switching strips		39	

1) Attachment kit also available without motor (when ordering: enter "00" for motor)

Length L:

$$L = (\text{effective stroke} + 2 \cdot \text{excess travel } s_e) + 120 \text{ mm} + L_{ca}$$

Effective stroke = maximum travel of carriage center (CC) between the outermost switch activation points.

The excess travel s_e must be longer than the braking distance. The acceleration travel can be taken as a guideline value for the braking distance.

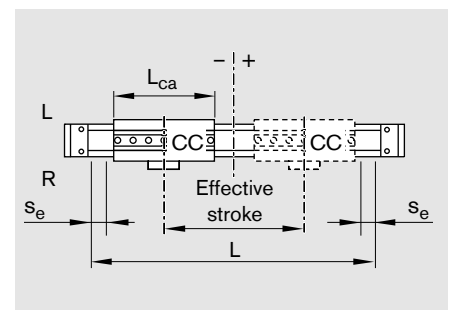

⚠ Note for length calculations for the version "Carriage without clamping unit":

The switch mounting profile is 260 mm long.

Add 30 mm to the calculated length L.

OBB 55

Dimensions

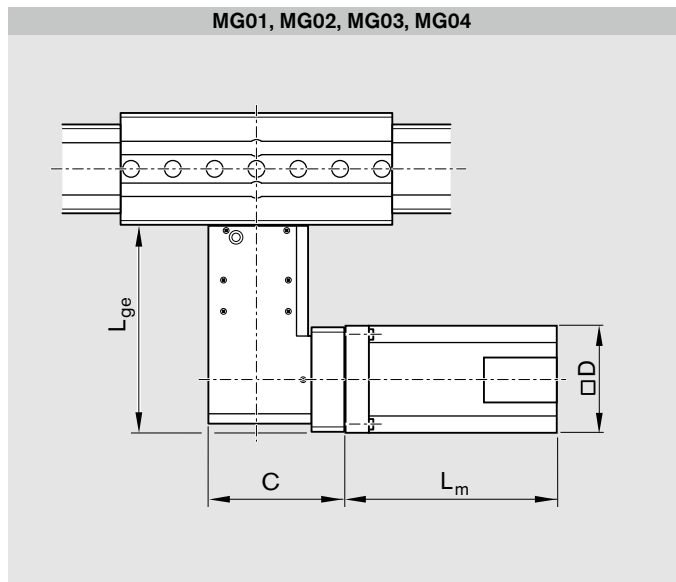
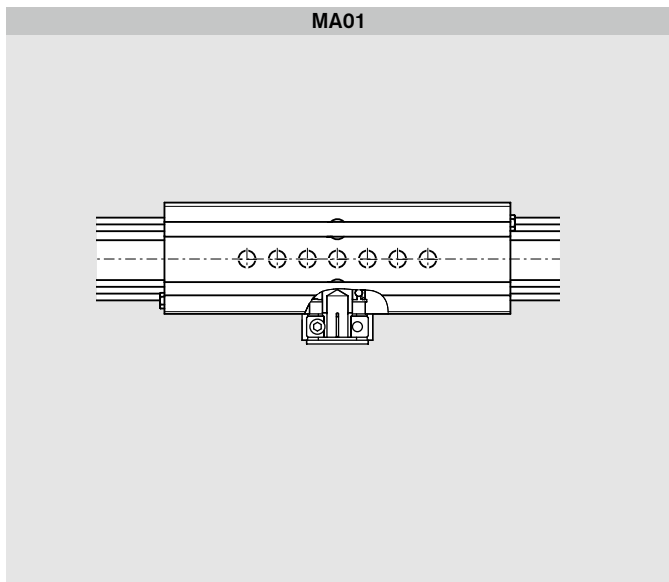
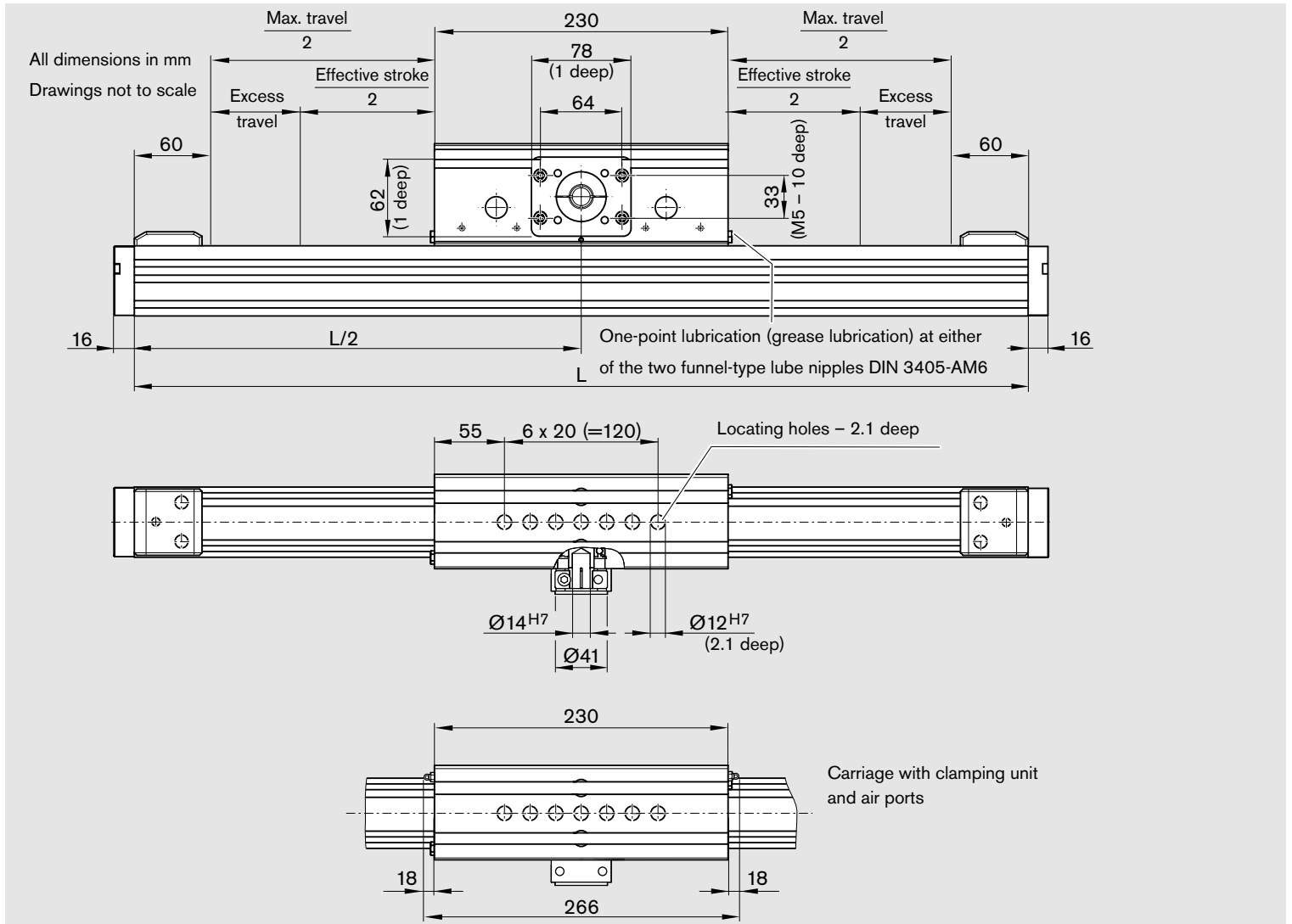

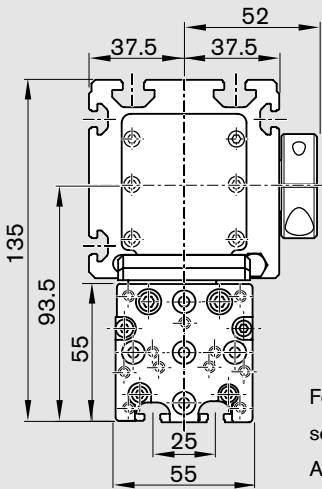

For dimensions of end plate, see section "Attachment of Add-on Modules"

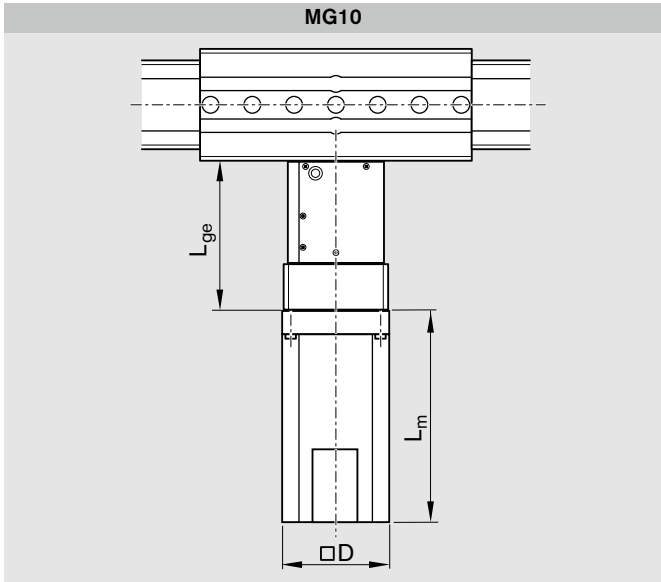
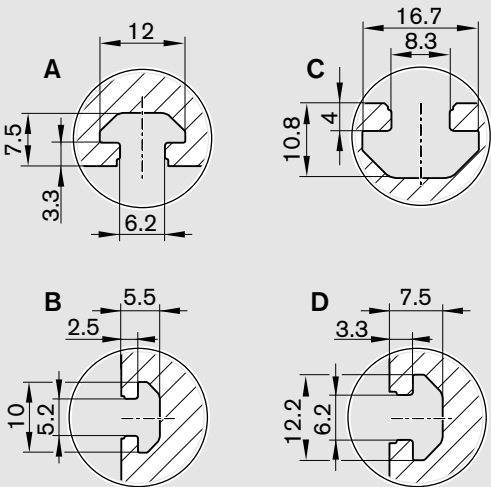
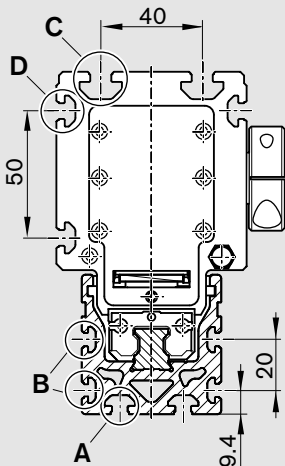
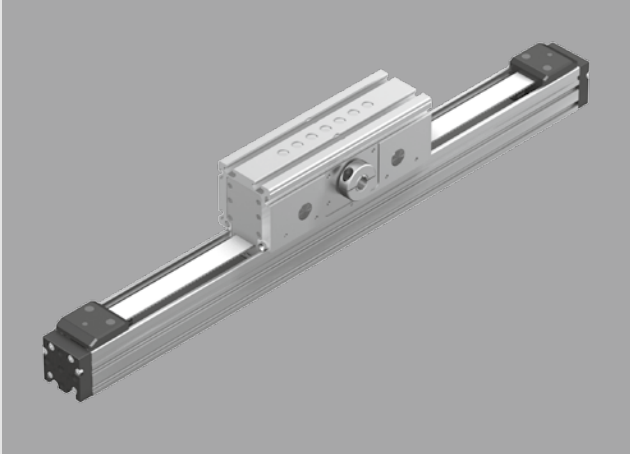

Motor	Dimensions (mm)					
	Gear unit			Motor		
	L _{ge}	C	L _{ge}	D	without brake	L _m with brake
MSK 040C	150.5	97.5	111.5	82	185.5	215.5
MSM 031C	135.5	97.5	111.5	60	98.5	135

OBB 85

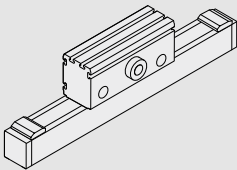
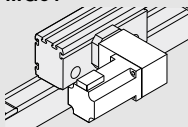
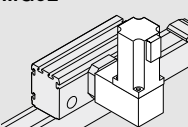
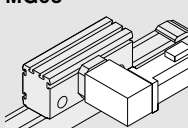
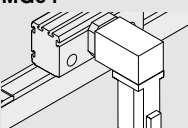
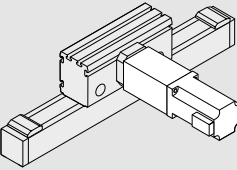

Components and Ordering Data

Part number, length R1144 300 00, mm		Guideway	Drive unit			Carriage	
Version			Reduction			$L_{ca} = 260$ mm	$L_{ca} = 344$ mm
			i = 1	i = 5	i = 8	without Clamping unit	with Clamping unit
With drive unit (MA), w/o gear reducer $i=1$	MA01 	01	Clamping shaft	01	-	01	02
With gear reducer (MG), angled gear reducer WPLE	MG01 	01	Angled gear reducer at left / at top / at right / at bottom	-	10	01	02
	MG02 						
With gear reducer (MG), straight gear reducer PLE	MG03 	01	Straight gear reducer at side	-	10	01	02
	MG04 						
With gear reducer (MG), straight gear reducer PLE	MG10 	01	Straight gear reducer at side	-	10	01	02

Ordering example: see "Inquiry/Order"

L_{ca} = carriage length

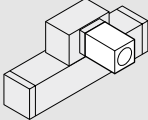
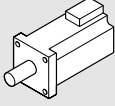
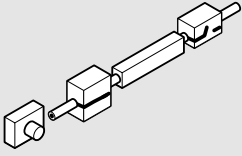
Please check whether the selected combination is a permissible one (load capacities, moments, maximum speeds, motor data, etc.)!

Motor attachment			Motor	Switches / Cable duct / Socket-plug		Documentation
						
Reduction i =	Attachment kit ¹⁾ MG01 MG02 MG03 MG04		for motor	without	with	Standard report
				Brake		
-	00		-	00		01
i = 5	33	43	MSK 050C	88	89	
i = 8	35	45				
i = 8	34	44	MSM 041B	110	111	
i = 5	30		MSK 050C	88	89	
i = 8	32					
i = 8	31		MSM 041B	110	111	
Without switch and cable duct 00						
Carriage travels						
Switches: - PNP NC 71 ± ... mm - PNP NO 73 ± ... mm - Mechanical 75 ± ... mm						
Ordering data: Switch type _____ Travel direction _____ Switching distance _____						
Cable duct – length 20 - ... mm						
Socket-plug 17						
One switching strip 36						
Frame travels						
Switches: - PNP NC 61 ± ... mm - PNP NO 63 ± ... mm - Mechanical 65 ± ... mm						
Socket-plug 17						
One switching strip 40						
Two switching strips 41						

1) Attachment kit also available without motor (when ordering: enter "00" for motor)

Length L:

$$L = (\text{effective stroke} + 2 \cdot \text{excess travel } s_e) + 120 \text{ mm} + L_{ca}$$

Effective stroke = maximum travel of carriage center (CC) between the outermost switch activation points.

The excess travel s_e must be longer than the braking distance. The acceleration travel can be taken as a guideline value for the braking distance.

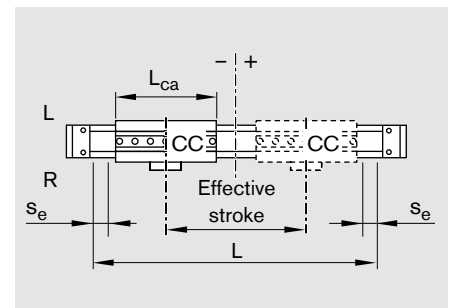

OBB 85

Dimensions

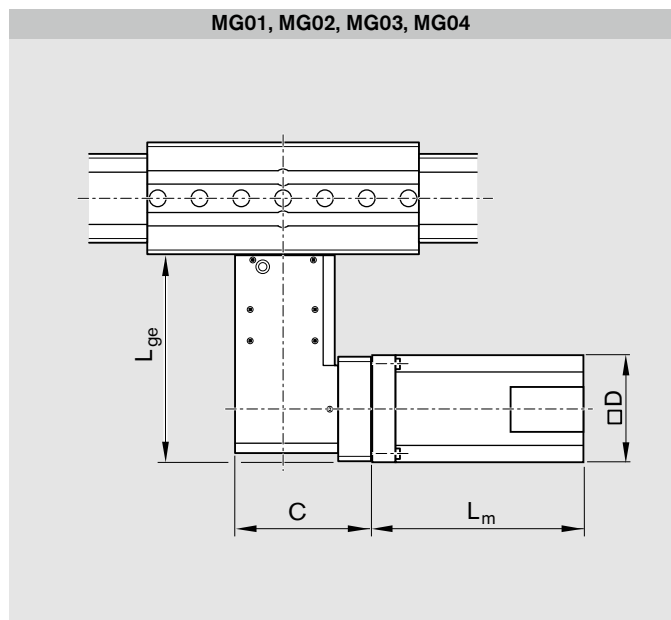
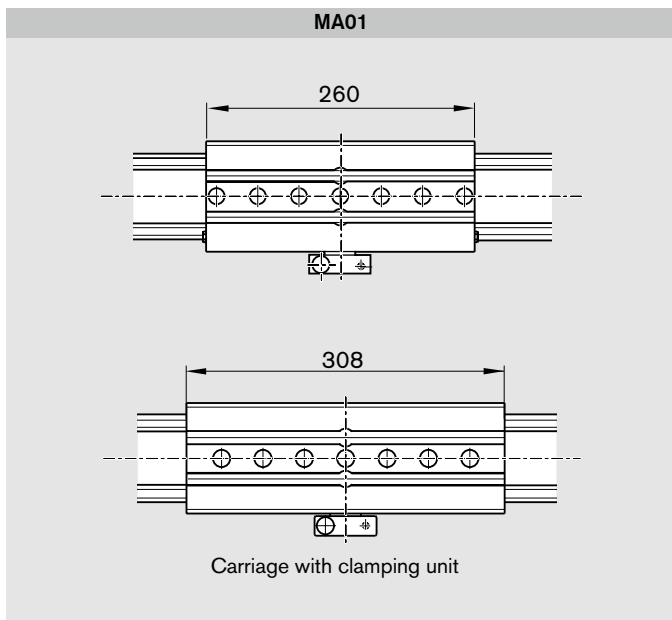
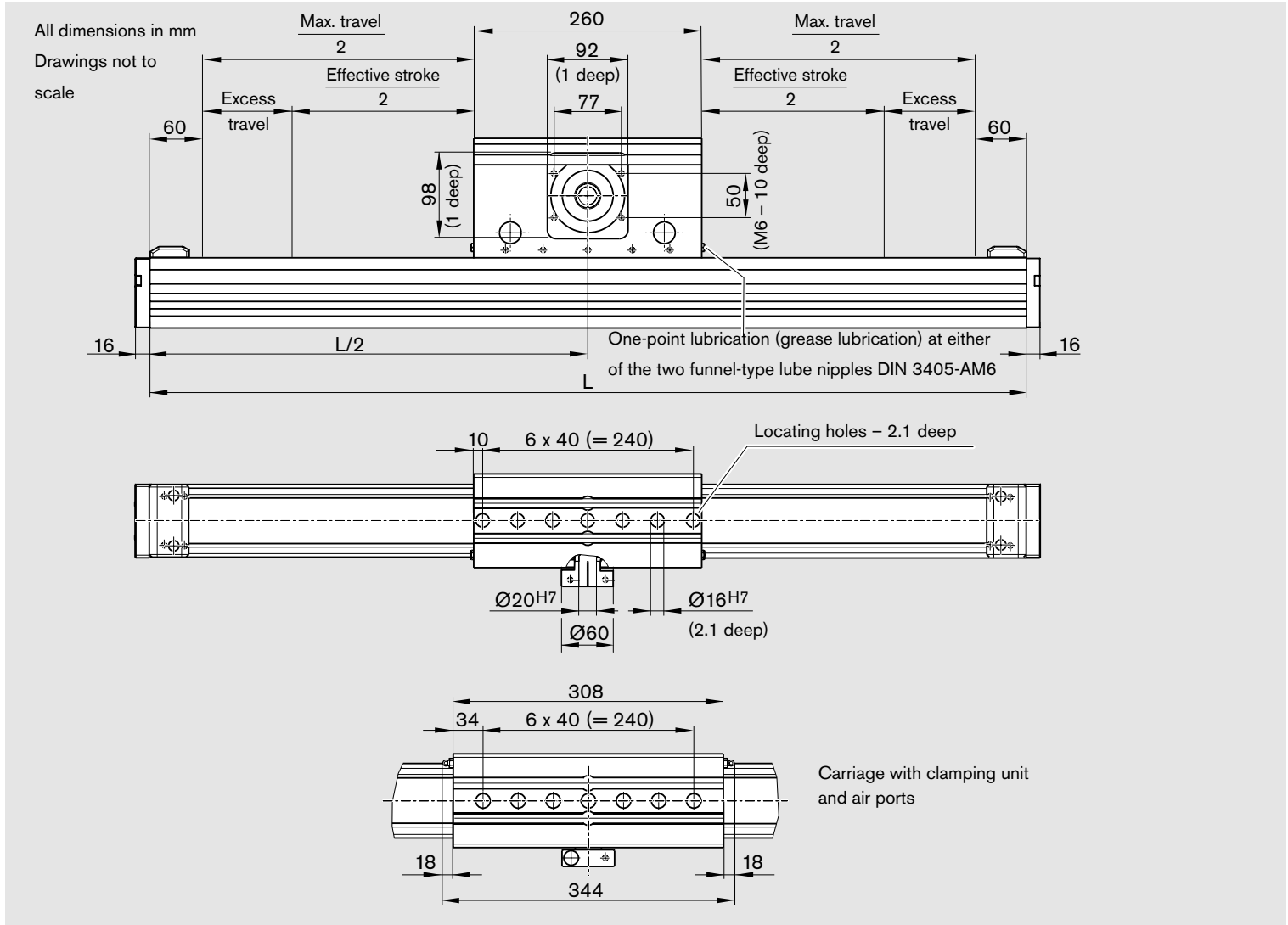

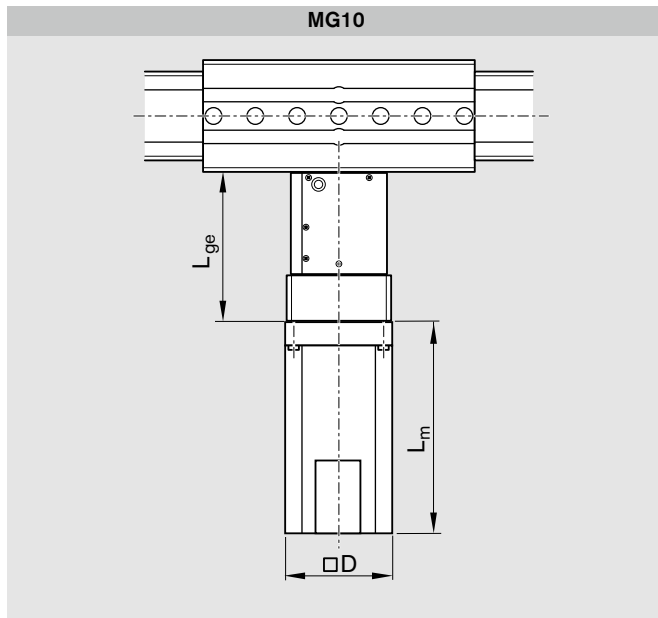
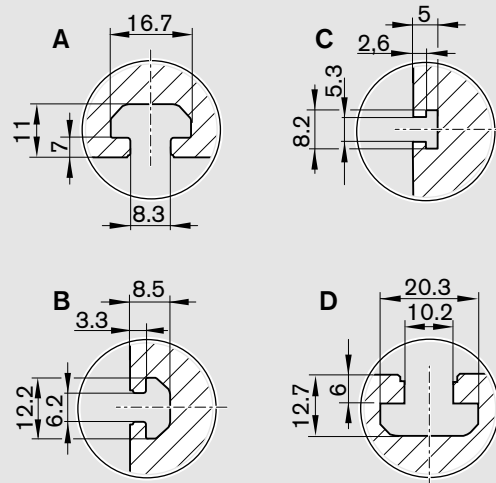
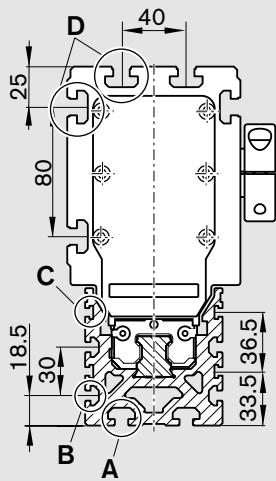
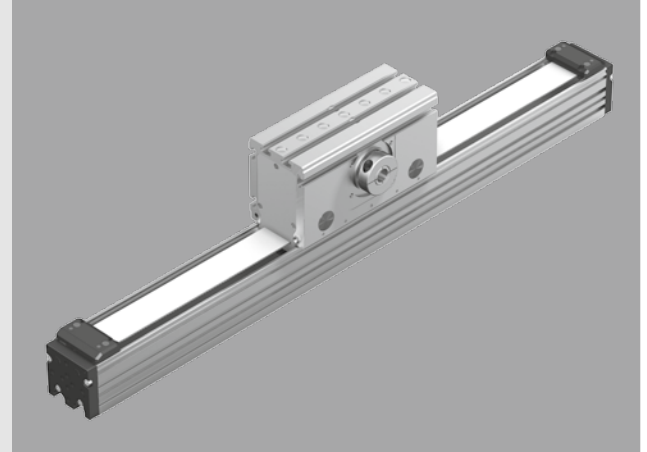
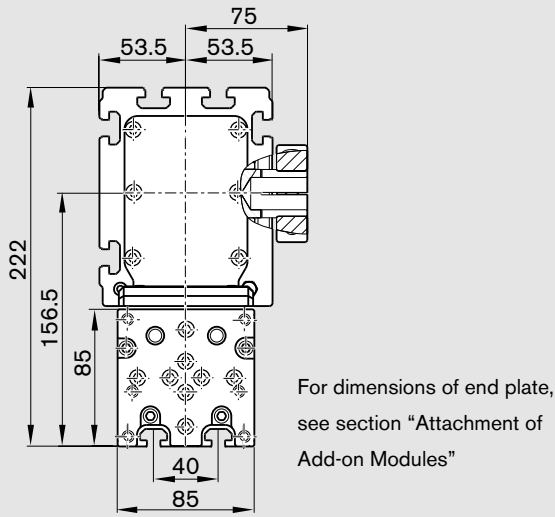

Motor	Dimensions (mm)					
	Gear unit			Motor		
	L _{ge}	C	L _{ge}	D	without brake	L _m with brake
MSK 050C	192.5	124.5	142	98	203.0	233.0
MSM 041B	187.5	124.5	142	80	112.0	149.0

OBB 120

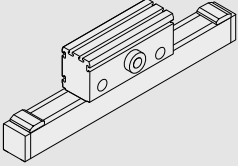
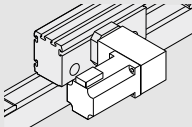
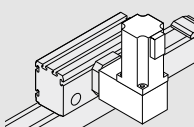
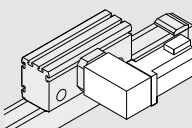
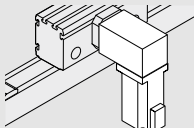
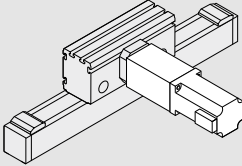

Components and Ordering Data

Part number, length R1144 600 00, mm		Guideway	Drive unit		Carriage		
Version			Reduction		$L_{ca} = 330$ mm without	$L_{ca} = 366$ mm with	
			i = 1	i = 9	Clamping unit	Clamping unit	
With drive unit (MA), w/o gear reducer $i=1$	MA01 	01	Clamping shaft	01	-	01	02
With gear reducer (MG), angled gear reducer WPLE	MG01 	01	Angled gear reducer at left / at top / at right / at bottom	-	10	01	02
	MG02 						
	MG03 	01	Angled gear reducer at left / at top / at right / at bottom	-	10	01	02
	MG04 						
With gear reducer (MG), straight gear reducer PLE	MG10 	01	Straight gear reducer at side	-	10	01	02

Ordering example: see "Inquiry/Order"

L_{ca} = carriage length

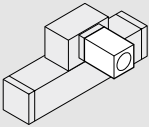
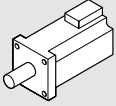
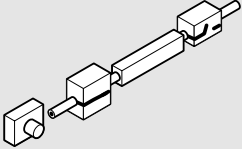
Please check whether the selected combination is a permissible one (load capacities, moments, maximum speeds, motor data, etc.)!

Motor attachment				Motor	Switches / Cable duct / Socket-plug		Documentation
							 Standard report
Reduction $i =$	Attachment kit ¹⁾ MG01 MG02 MG03 MG04		for motor	without with Brake			
-	00		-	00	Without switch and cable duct 00 <hr/> Carriage travels Switches: - PNP NC 71 ± ... mm - PNP NO 73 ± ... mm - Mechanical 75 ± ... mm Ordering data: Switch type Travel direction Switching distance <hr/> Cable duct – length 20 - ... mm <hr/> Socket-plug 17 <hr/> One switching strip 36 <hr/> Frame travels Switches: - PNP NC 61 ± ... mm - PNP NO 63 ± ... mm - Mechanical 65 ± ... mm <hr/> Socket-plug 17 <hr/> One switching strip 42 <hr/> Two switching strips 43		01
$i = 9$	31	32	MSK 076C	92	93		
$i = 9$	30		MSK 076C	92	93		

1) Attachment kit also available without motor (when ordering: enter "00" for motor)

Length L:

$$L = (\text{effective stroke} + 2 \cdot \text{excess travel } s_e) + 160 \text{ mm} + L_{ca}$$

Effective stroke = maximum travel of carriage center (CC) between the outermost switch activation points.

The excess travel s_e must be longer than the braking distance. The acceleration travel can be taken as a guideline value for the braking distance.

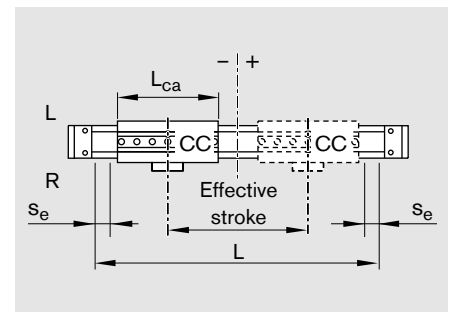

OBB 120

Dimensions

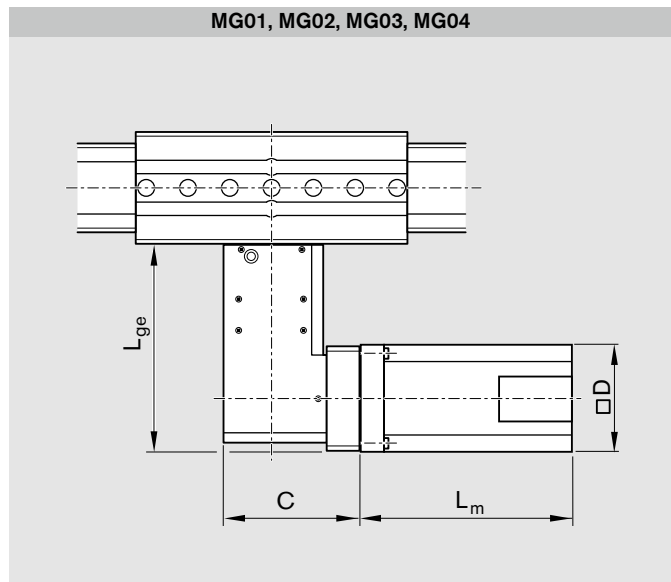
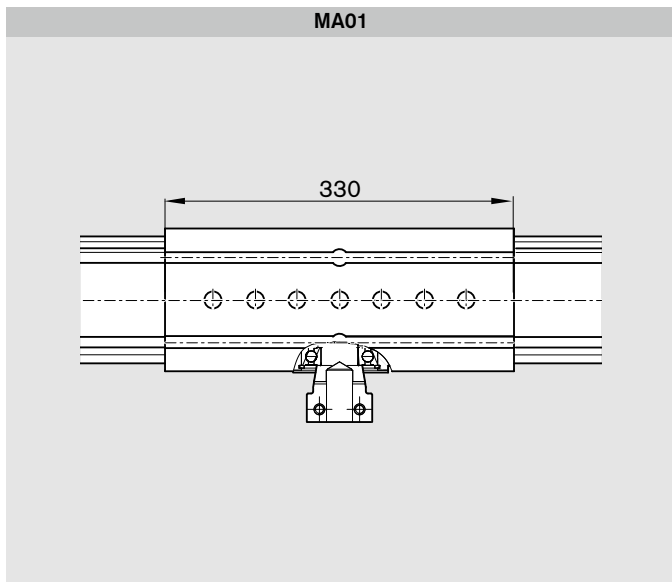
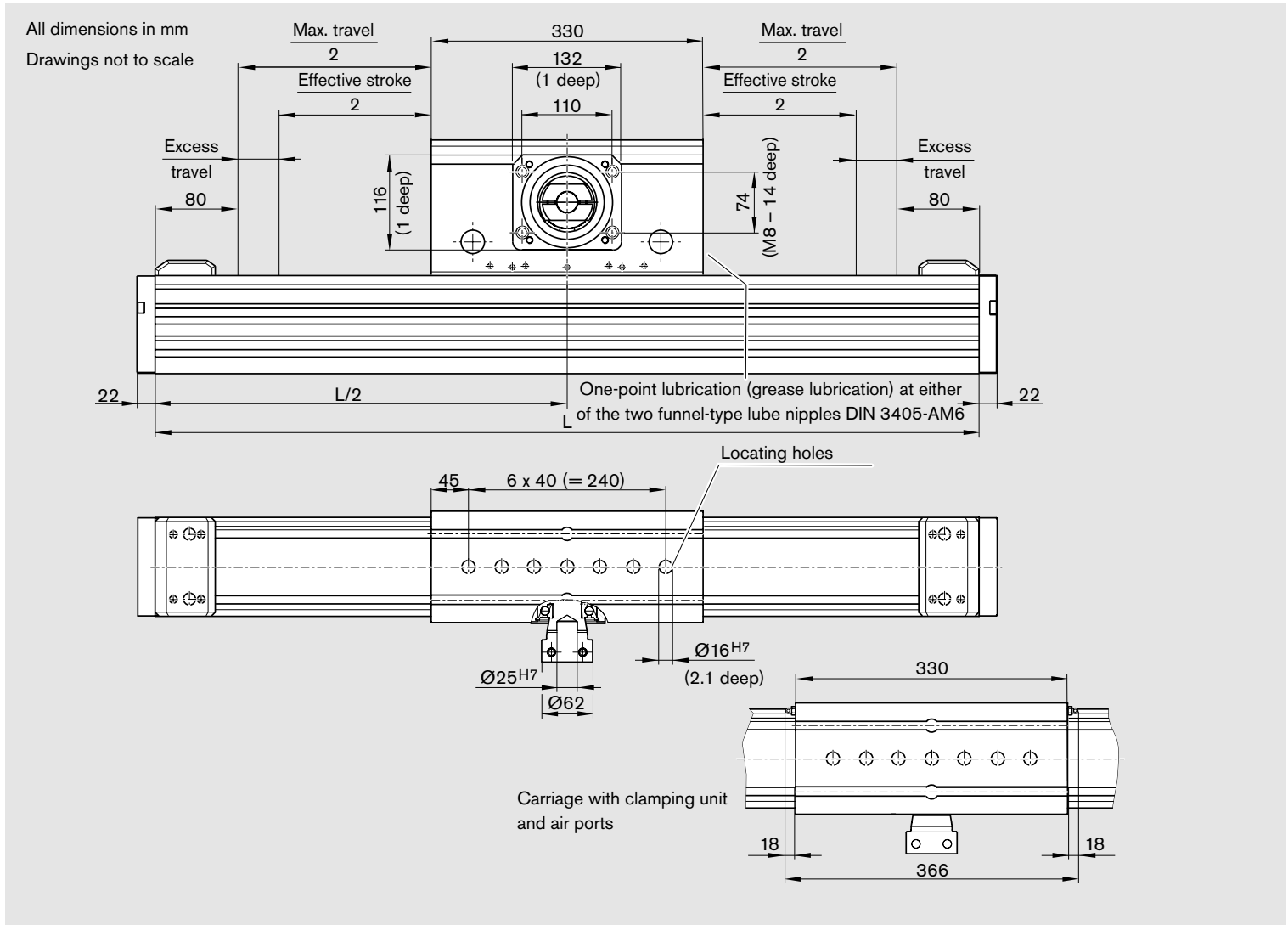

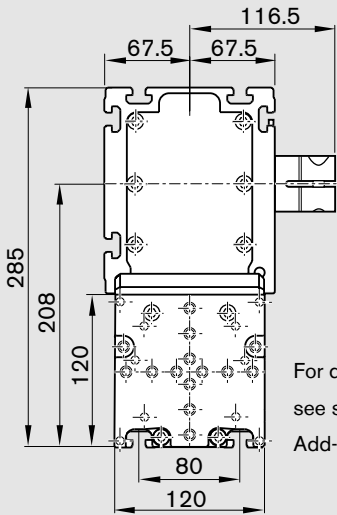

For dimensions of end plate, see section "Attachment of Add-on Modules"

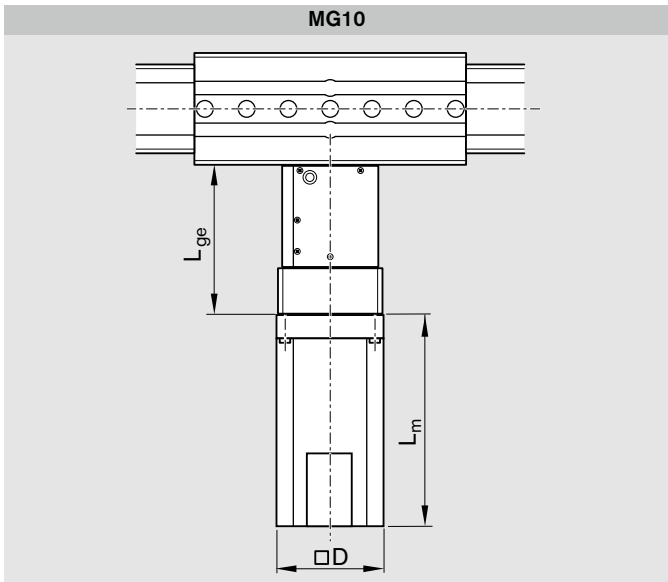
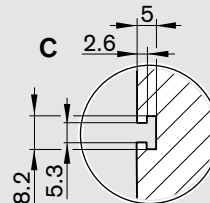
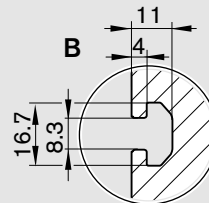
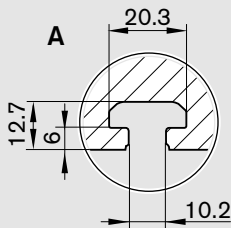
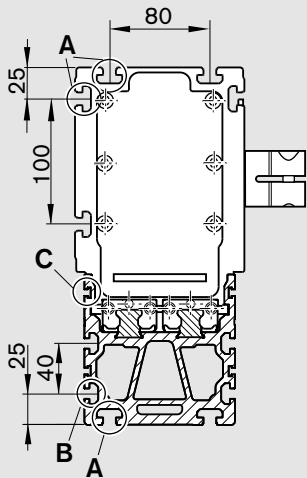
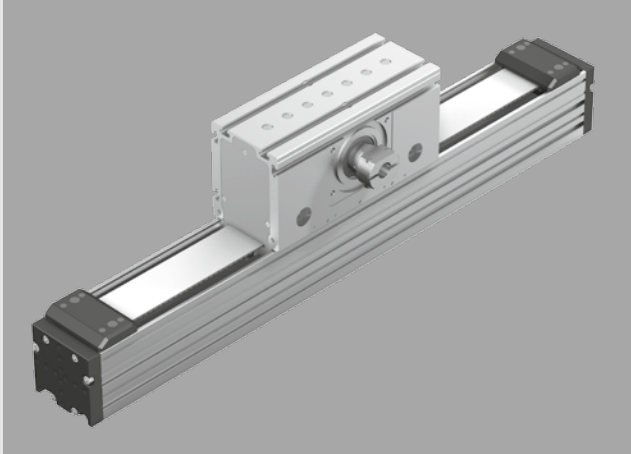

Motor	Dimensions (mm)			Motor		
	L _{ge}	C	L _{ge}	D	without brake	L _m with brake
MG01	287.5	155.5	212	140	292.5	292.5
MG02						
MG03						
MG04						
MSK 076C	287.5	155.5	212	140	292.5	292.5