

## Start-up and Maintenance

### Start-up

Initial lubrication of runner blocks is necessary before Miniature Ball Rail Systems are put into service if block is ordered without lube.

i.e. R0442 513 01 = prelubricated  
R0442 513 41 = no lube

Runner blocks are available:

- prelubricated with a lithium soap grease, consistency class NLGI 00, Dynalub 520
- without initial lubrication for individual grease or oil lubrication.

### Initial lubrication with grease

We recommend a grease lubricant to DIN 51825, class KP00K.

A grease of this type, Dynalub 520, is available in the following versions:

- Maintenance kit with 5 ml dispensing unit Part no. R0419 090 01
- 400 g cartridge for use in grease guns Part no. R3416 043 00

Note:

- Grease the runner block as per table.
- Move the runner block toward the lube port used to distribute the grease evenly.
- Make sure there is a visible film of grease on the guide rail.

### Initial lubrication with oil

We recommend the use of oils meeting the minimum requirements for CLP lubricant oils (DIN 51517, Part 3) or HLP hydraulic oils (DIN 51524, Part 2). The oil must have a viscosity of 100 mm<sup>2</sup>/s at 40°C.

- Observe the manufacturer's instructions.
- It is essential to check that the lubricant will reach all rolling bearings in the installed condition (orientation).
- Apply oil until excess emerges.

 Add the entire oil quantity in one pulse!

### Maintenance

The maintenance intervals depend on the application and the ambient conditions.

Under normal conditions no in-service lubrication is required.

### Cleaning

Dirt can settle and encrust on the guide rails, especially when these are not enclosed.

- Always run a cleaning cycle before shutting down the machine.

This dirt must be removed to protect the seals.

### In-service lubrication

Initial lubrication (long-term lubrication) is sufficient for 5,000 km travel where:

- $F < 0.1 \text{ C}$
- $V_m = 0.65 \text{ m/s}$
- $> 90 \text{ mm stroke}$
- low-friction seals
- For in-service lubrication with grease or oil, follow instructions as for initial lubrication.

Ambient conditions include: swarf, metallic and other abrasion, solvents and temperature.

Types of load include: vibrations, impacts and tilting.

 The service conditions are unknown to the manufacturer. Users can only determine the in-service lubrication intervals with certainty by conducting in-house tests or by careful observation.

 The in-service lubrication intervals depend on ambient conditions, loading and type of load!

 Do not allow guide rails or runner blocks to come into contact with water-based coolants!

### Service kit

A **special syringe** is used to apply lubricant to the **lube ports** at the sides or end faces of the runner block (part number: 0419-090-01).

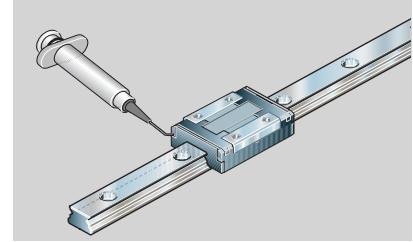
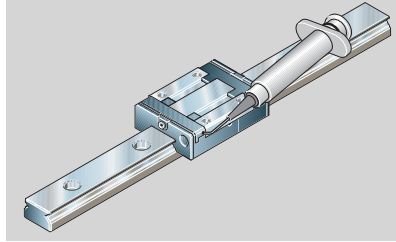

If the **funnel-type lube nipples** on the runner block end faces are preferred, use a **grease gun** instead.

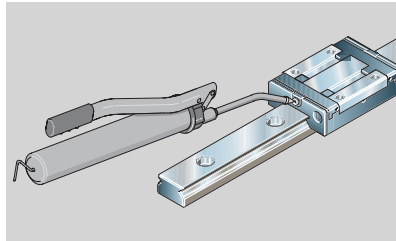

### Short stroke (stroke < 2 runner block lengths)

See "Lubrication quantities and methods" for the method to be used for short stroke applications.

For strokes < 0.5 runner block length, slide the runner block over 2 complete runner block lengths per lubrication cycle. If this is not possible, please consult us.

## Lubrication Quantities and Methods

The lubrication method depends on the size, as given in the table:

Size	Lubrication by	
	Method 1	Method 2
<b>Standard runner block R0442</b>		
7	✓	
9/M3	✓	
12	✓	
15		
20		✓
<b>Wide runner block R0443</b>		
9/M3 wide		✓
12 wide	✓	
15 wide	✓	
		✓
<b>Long runner block R0444</b>		
7	✓	
9/M3	✓	
12	✓	
15		✓

### Method 1

Apply lubricant through the lube ports on the end face.

Size	Initial lubrication with grease	
	Partial amount per side (L/R) [cm <sup>3</sup> ]	Total amount (L+R) [cm <sup>3</sup> ]
<b>Standard runner block R0442</b>		
7	0.025	0.05
9/M3	0.030	0.06
12	0.075	0.15
<b>Wide runner block R0443</b>		
9/M3 B	0.040	0.08
12 B	0.075	0.15
<b>Long runner block R0444</b>		
7	0.040	0.08
9/M3	0.045	0.09
12	0.120	0.24

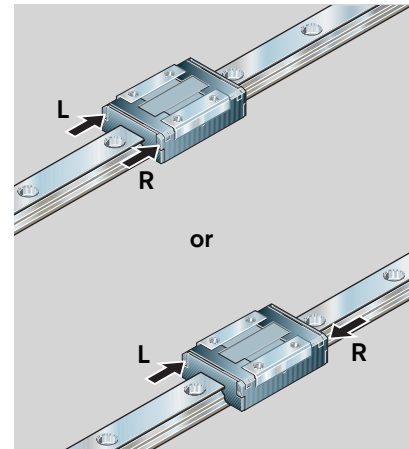

For **short stroke** applications, apply the partial amount per side as given in the table to each end-face lube port.

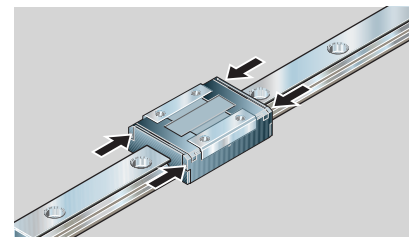

**Method 2**

Apply lubricant through the lube ports at the sides or the lube nipples on the end face.

Size	Initial lubrication with grease	
	Partial amount per side (L/R) [cm <sup>3</sup> ]	Total amount via end face [cm <sup>3</sup> ]
<b>Standard runner block R0442</b>		
15	0.06	0.12
20	0.09	0.18
<b>Wide runner block R0443</b>		
15 B	0.09	0.18
<b>Long runner block R0444</b>		
15	0.10	0.20

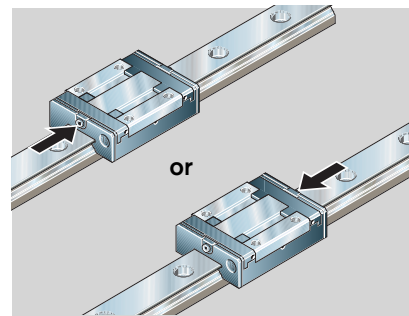
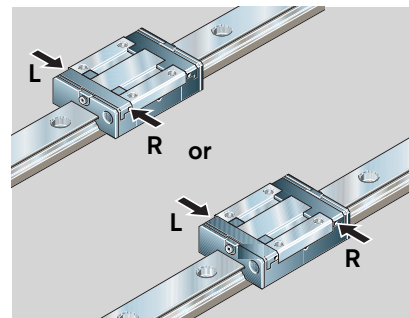

For **short stroke** applications, apply either the total amount as per table to each end-face lube nipple, or the partial amount per side as given in the table to each side lube port.

