

Lubrication

Lubrication notes

Basic lubrication is applied in-factory before shipment.

Feed Modules are designed for grease lubrication (using a manual grease gun with an extension tube and nozzle).

The only maintenance required is lubrication of the guideway and the ball screw via the two lube ports.

Lubricant must be applied to both of the lube ports.

The thrust rod must be fully extended before applying lubricant.

Lube ports for:

- 1 Runner blocks
- 2 Ball screw

Recommended lubricants

For lubricant quantities and intervals, see "Mounting Instructions for Feed Modules."

⚠ Do not use greases containing solid particles (e.g., graphite or MoS₂)!

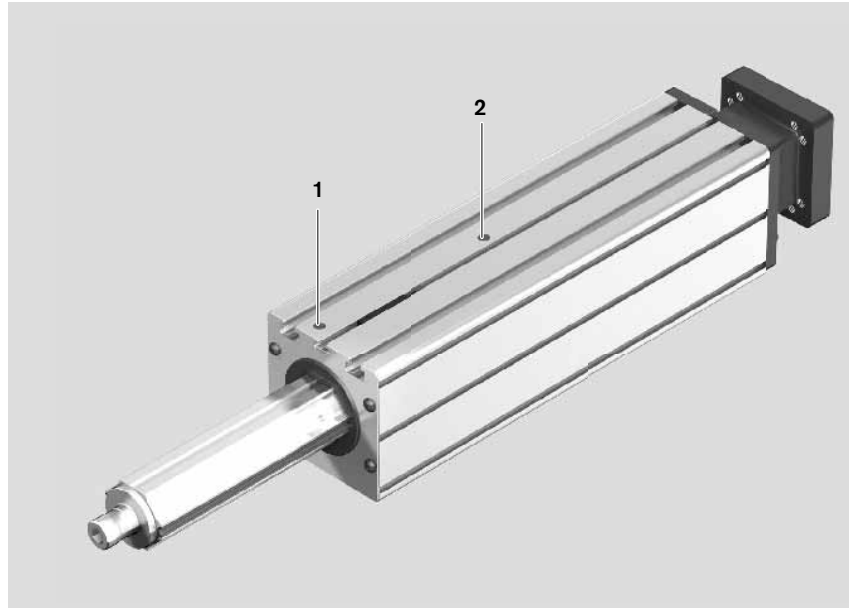

Frame size	Grease DIN 51825	Consistency class DIN 51818
70	KP2K	NLGI 2
100		