

Electromechanical Cylinders EMC

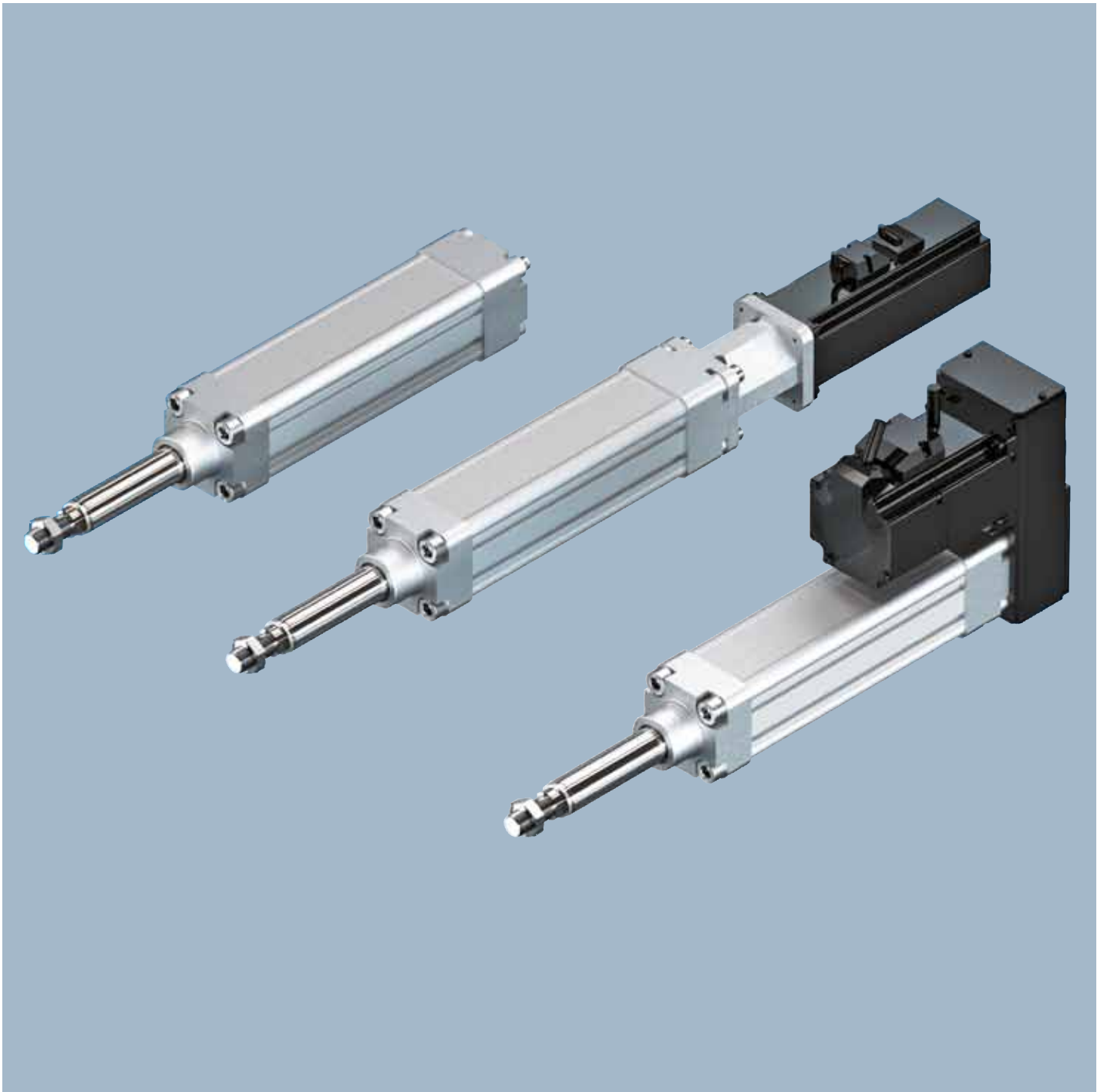

Electromechanical Cylinders EMC

Standards and Safety	4
A Solution to Many Problems	8
Product Overview	10
Structural Design	14
Technical Data and Dimensions EMC	15
EMC with Motor Mount and Coupling	18
EMC with Belt Side Drive	20
Permissible Speeds	22
Permissible Drive Torque M_p	24
Maximum Axial Loading of Mechanical Cylinder System F_{max}	26
Calculations	28
Switch Mounting Arrangements, Magnetic Field Sensor	30
Mounting Elements	32
For EMC with belt side drive and motor	32
For EMC with motor mount and motor	33
Part numbers	34
Dimensions	35
Lubrication	44
Motors	46
Overview	46
AC servo motors MSK	47
AC servo motors MSM	48
Configuration and Ordering	50
Inquiry / Order Form	56
Technical Inquiry Sheet for Electromechanical Cylinders	57

Standards and Safety

New standards with new requirements – no problem, thanks to Rexroth

Whether the task involves machine tools, packaging and printing machines, assembly, handling or robot applications, the protection of personnel, machines and tools is absolutely paramount. Safety is therefore a topic of prime concern to users and manufacturers alike, and one which demands intensive cooperation between the automation partner and the machine manufacturer. As an all-around automation partner, Rexroth provides access to unique know-how across all drive and control technologies and complying with requirements such as “safe motion”, “safe processing of peripheral signals” and “safe communication.”

As a technology leader, Rexroth offers consistent functional safety on all automation levels: from components through to system solutions including software, Rexroth provides machine manufacturers and end users with high-quality products based on the newest safety engineering.

Every manufacturer of plant and machinery is responsible for ensuring that his products meet basic safety requirements. The new European Machinery Directive 2006/42/EC and the Machinery Safety Standards EN ISO 13849-1 – in the latest revision – and EN 62061 provide the framework: In an extensive evaluation with statistical parameters, machine manufacturers must proof protection of personnel under consideration of all components and systems installed into the machine or production system.

The goal is to identify and reduce risks. Intrinsically safe designs therefore always have higher priority over protective safeguards and warning notices in the documentation. If hazards are to be minimized by the use of safety-critical control components, the EN ISO 13849-1 comes to bear. The machine manufacturer must specify the required performance level, i.e. the reliability, of the safety functions.

Your tasks...

In order to comply with the standards, machine manufacturers and their suppliers must perform the following tasks:

- As per European Machinery Directive 2006/42/EC: Risk assessment and reduction of risks.
- As per ISO 13849: Estimation of the reliability of safety functions dependent upon, e.g.
 - the hardware-oriented structure
 - the mean time to dangerous failure (MTTFd)
 - the diagnostic coverage (DC) of a safety function.

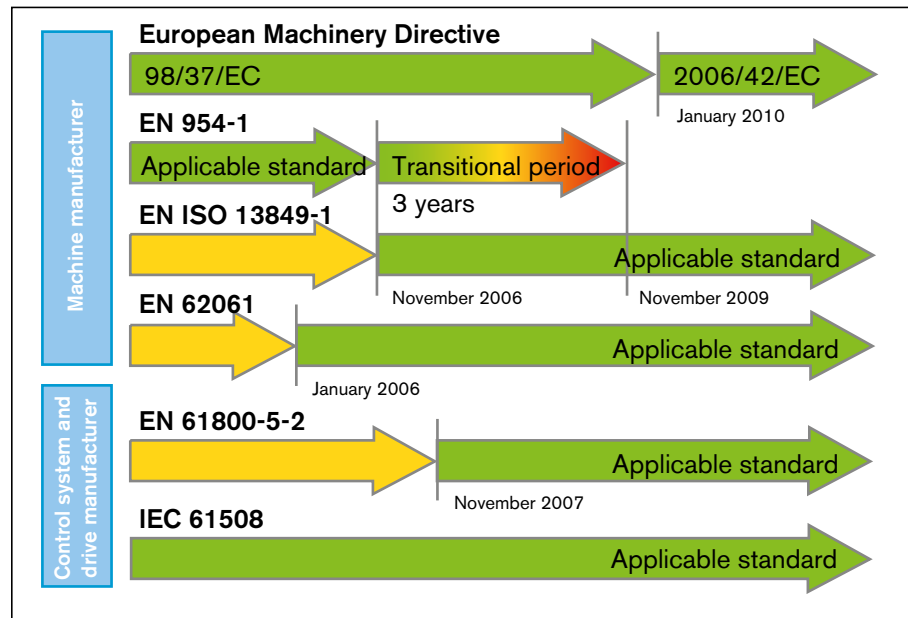

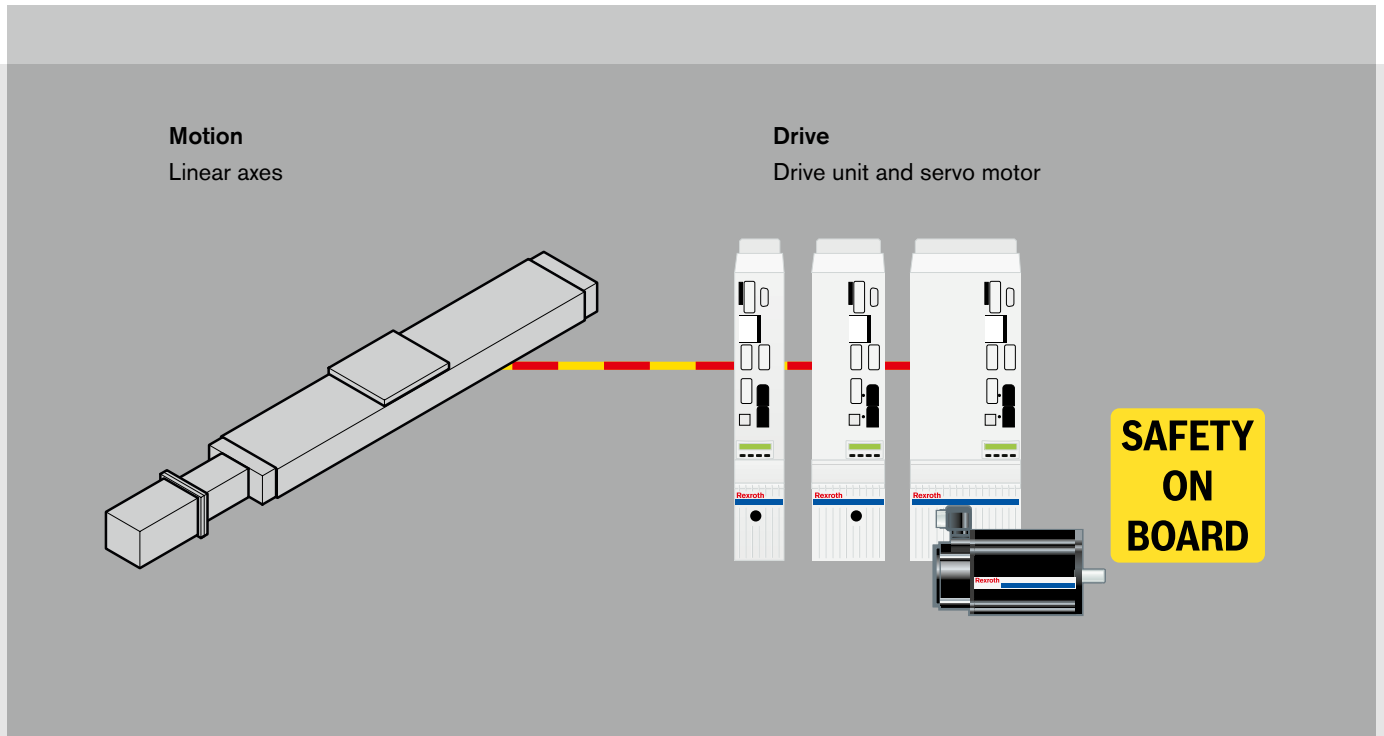

...our solutions

Rexroth provides perfectly matched certified control systems, controllers and motors with integrated functional safety, thereby making work easier for designers and machine manufacturers.

The benefits for you are:

- **reduced development effort** to comply with the new standards, e.g. through automation products with certified safety functions, certified components and tested circuits;
- **simplified design process** for safe machinery through single-source drive and control technologies;
- **effective protection of personnel** through safe movements in all drive technologies and the fast reaction of monitoring functions.

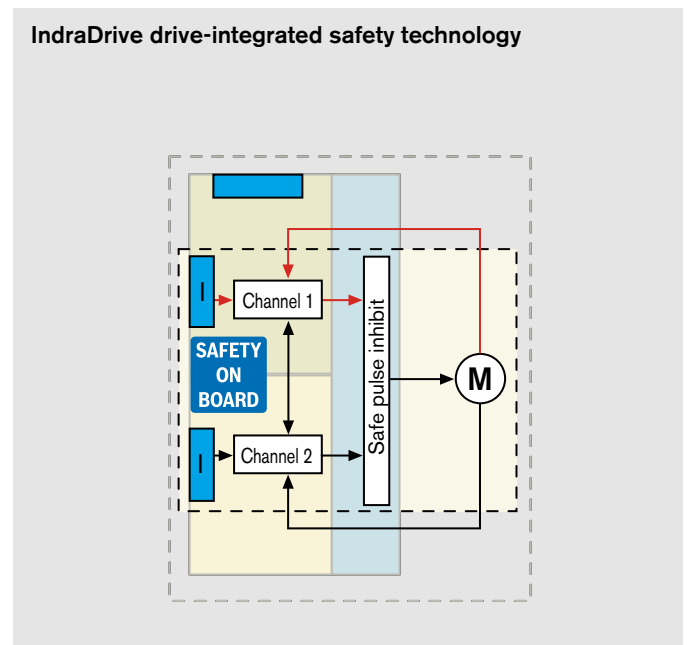
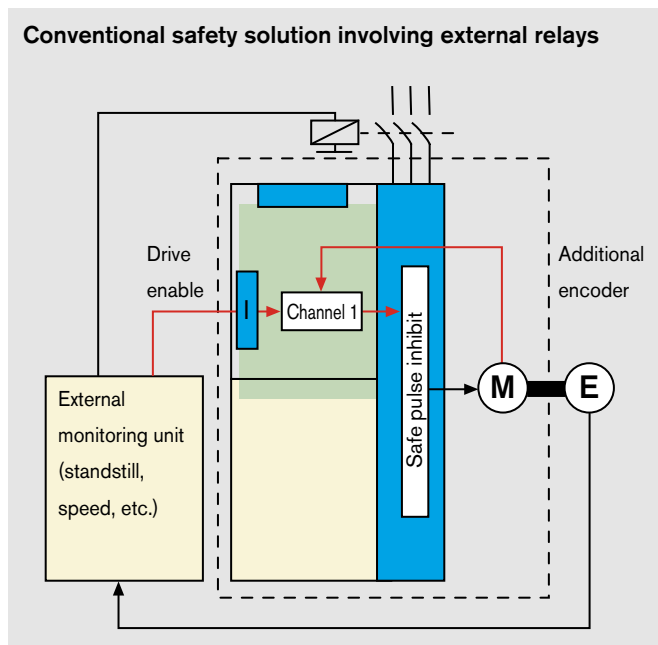

Standards and Safety

Our drives and controls – your safety

The safety technology is exclusively available for linear axes with MSK motors and IndraDrive.

The appropriate products carry a “SAFETY ON BOARD” label.

SAFETY ON BOARD

Safety on Board merges drive-based and controller-based safety solutions to form a smart comprehensive safety concept.

These safety solutions in our drive systems (IndraDrive) and controllers assure a high level of diagnostic coverage and hence a high availability of the safety functions.

Your advantages:

- Maximum protection for personnel
- Maximum safety and reliability
- Safety components tested and certified in accordance with the latest safety standards
- Functional and legal assurance
- Reduced downtime
- Increased availability
- Simplified start-up and validation
- Minimized cost and effort for validation
- Easy upgrading of standard components to full-fledged safety components
- Flexible use as stand-alone safety components or as part of a system solution

SafeMotion

The drive-integrated safety technology in IndraDrive from Rexroth monitors movements where they are generated. The results are very rapid response times of just 2 milliseconds upon triggering of the internal monitors.

Even in the case of a power failure, a hydraulic feed axis with mechanical clamping can come to a safe stop within milliseconds.

Rexroth provides these intelligent drive solutions as certified safety components with all the necessary proofs. SafeMotion is thus the first step in the realization of safe machine concepts.

Your advantages:

- Effective protection of personnel
- High reliability thanks to certified and integrated solution
- Maximum assurance against tampering through drive-integrated monitoring system
- Reduced design effort through savings on time and money spent on certification
- Increased availability through reduced downtimes
- Increased machine productivity as a result of shorter special mode times
- No unnecessary idle times because the line circuit breaker does not have to be opened when undertaking work on the machine
- No need for re-synchronization of coupled axes after intervention work on the machine
- Savings on limit switches, measurement and analysis units and control cabinet size
- Fault detection without the need for any periodic machine shutdown
- Can be integrated into any kind of system architecture
- Easy start-up
- Easy to service

For more information, refer to the brochure “Safety on Board – Functional Safety in Automation Technology,” R911 322 823.

SafeMotion – Certified safety functions

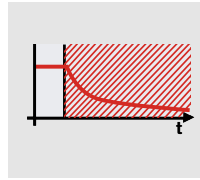

Safe Torque Off (STO)
Stop category 0 in accordance with EN 60204-1: Safe drive torque cut off

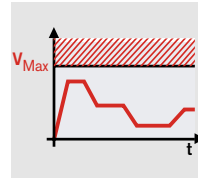

Safe Maximum Speed (SMS)
The maximum speed is safely monitored irrespective of the mode of operation

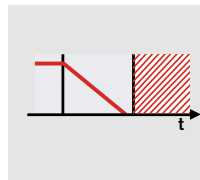

Safe Stop 1 (Emergency Stop) (SS1)
Stop category 1 in accordance with EN 60204-1: Safely monitored stop, control or drive controlled with safe drive torque cut off

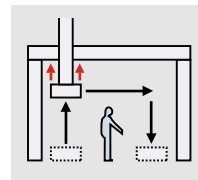

Safe Braking and Holding System (SBS)
The safe braking and holding system controls and monitors two independent brakes

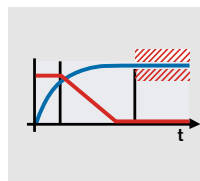

Safe Stop 2 (SS2)
Safe Operating Stop (SOS)
Stop category 2 in accordance with EN 60204-1: Safely monitored stop with safely monitored standstill at controlled torque

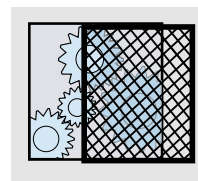

Safe Door Locking (SDL)
When all the drives in one protection zone are in safe status, the safety door lock is released

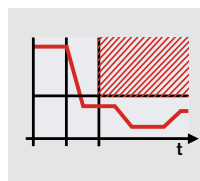

Safely Limited Speed (SLS)
If enable signal is given, a safely limited speed is monitored in special operating mode

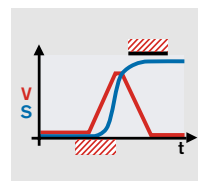

Safely Limited Increment (SLI)
If enable signal is given, a safely limited increment is monitored in special operating mode

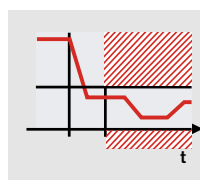

Safe Direction (SDI)
A safe direction (clockwise, counter-clockwise) is also monitored in addition to safe motion

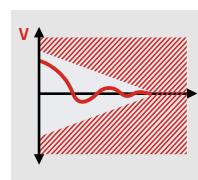

Safely Monitored Deceleration (SMD)
Safely monitored deceleration ramp when stopping

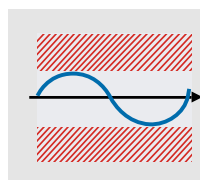

Safely Monitored Position (SMP)
A safe absolute position range is also monitored in addition to safe motion

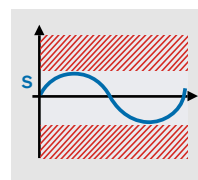

Safely Limited Position (SLP)
Monitoring of safe software limit switches



Safe Inputs/Outputs (SIO)
Dual-channel safety peripherals can be connected to the drive and made available to the controller via the safety bus

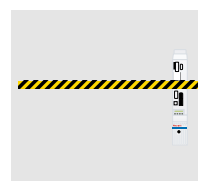

Safe Communication (SCO)
Selection/deselection of safety functions and transfer of process data (e.g. actual position values) via safety bus

All safety functions are certified as compliant with standards ISO 13849-1:2006¹⁾, IEC 61800-5-2:2007¹⁾, IEC 61508:1998-2000¹⁾, IEC 62061¹⁾, ISO 13849-1:1999, EN 954-1:1996, ISO 13849-2:2003, IEC 60204-1:1997, EN 50178-1:1997, IEC 61800-3:2004, UL 508C R7.03, C22.2 No. 0.8-M86 (R2003), CAN/CSA C22.2 No. 14-95, NFPA 79:2007 ER1 through TÜV Rheinland, TÜV Rheinland North America Inc. and SIBE Switzerland.

1) In preparation

A Solution to Many Problems

The tasks

- Driving
- Actuating
- Positioning
- Pressing / Joining
- Forming
- Dispensing

Maximum travel

Load ratings

Maximum load

Travel speed

System complete with drive unit

Switch mounting arrangements

Accessories

Up to 1,500 mm

Load capacity C up to 29,000 N

Up to 29,000 N

Up to 1.6 m/s

AC servo motor
with motor mount, coupling or timing belt side drive;
complete with controller and control system

Electronical switches
adjustable over the entire travel range

Mounting elements

The solution

**Rexroth
Electromechanical
Cylinders**

Product Overview

Electromechanical Cylinders EMC

Because of the actuator choices that electromechanical drive solutions offer, they are becoming more and more widespread as an alternative to fluid driven technology. The Electromechanical Cylinder EMC from Rexroth is a powerful alternative to pneumatic cylinders while providing significant benefits in terms of energy efficiency, a prime goal in engineering today. It also offers clear conceptual advantages, allowing travel to any intermediate target position as well as creating greater flexibility through higher thrust and variable speeds. Combinations of the various technologies can also result in new application possibilities.

The mechanics are based on established rolled precision ball screw drives available in all current diameter and lead combinations. Performance characteristics such as positioning accuracy, thrust or speed can be optimized to meet the requirements of each specific application.

Through the use of generously sized angular-contact thrust ball bearings LAN, the load rating of the ball screw drive is used to its maximum potential. There are also many choices and possibilities when it comes to drive configurations and mounting elements.

System advantages

- Many sizes to choose from
- Integrated ball screw drive ensures exact positioning and powerful thrust capability
- Motor attachment via motor mount and coupling or via belt side drive
- Compact construction
- Dynamic drive
- Extensive series of attachments to match every application area
- Quick assembly
- Compatible with other products from Bosch Rexroth
- Stainless steel piston rod
- Optional attachment of Rexroth standard components
- Particularly efficient in applications with a small number of axes
- Preferred stroke lengths: 100, 200, 320 and 400 mm with shorter delivery times
- Low maintenance
- High mechanical efficiency

Ball screw drives used

EMC size	d ₀	Ball screw Lead P						
		5	10	16	20	25	32	40
32	12							
40	16							
50	20							
63	25							
80	32							
100	40							

Application examples

There are many application areas where an EMC can be used, either as a replacement for, or in conjunction with pneumatic and hydraulic technology.

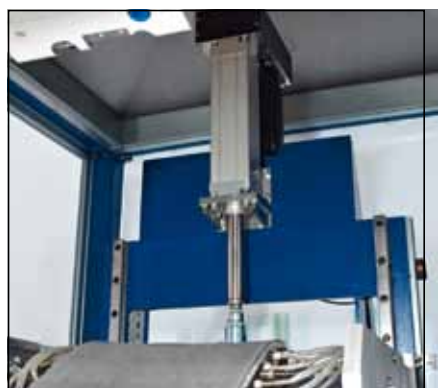

Joining and pressing

Application of contact pressure

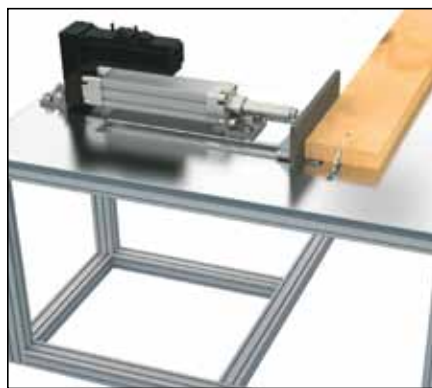

Machine tools or woodworking machines

Adjustable mechanical stop for a saw



Dispensing systems

Valve timing

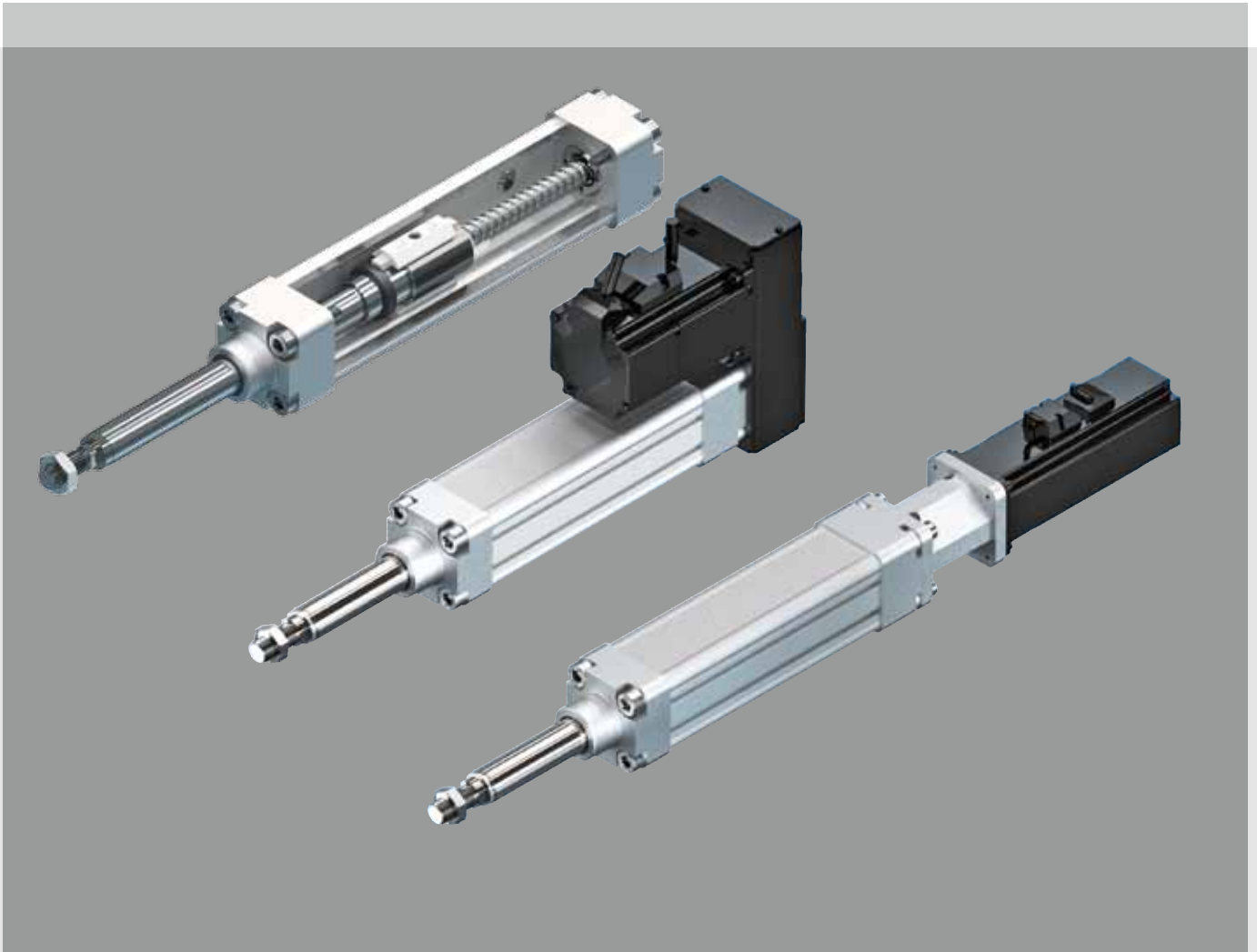

Further application areas:

- Material handling and feed systems
- Test rigs and laboratory applications
- Actuator drives (brush rollers / sensor units / grinding wheels, etc.)
- Welding, bonding, thermoforming
- Volumetric filling

At www.boschrexroth.com/emc, you can use the online configurator to select and order your EMC and generate CAD models.

Product Overview

Motor Selection

Based on drive controllers and control system

A choice can be made between several different motor/controller combinations to achieve the most cost-effective solution for each customer application. When sizing the drive, always consider the motor-controller combination. For more detailed information on motors and control systems, please refer to the catalogs "IndraDrive Cs for Linear Motion Systems" and "IndraDrive C for Linear Motion Systems."

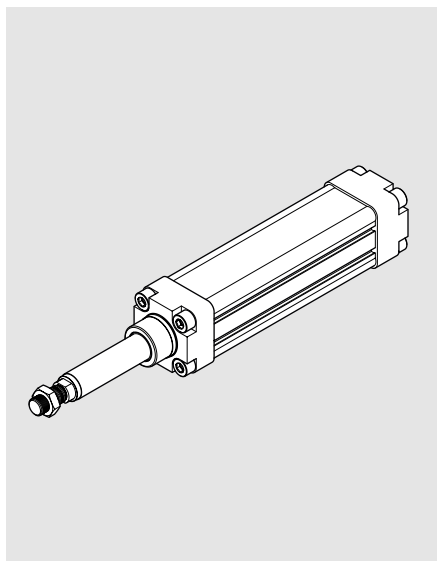

**SAFETY
ON
BOARD**

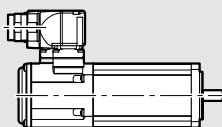

Digital AC Servo Motor MSK

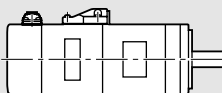

Digital AC Servo Motor MSM

**SAFETY
ON
BOARD**

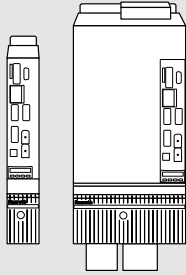

**Digital controller
IndraDrive C**
Power unit HCS 02
Control unit CSH



**Digital controller
IndraDrive Cs**
HCS 01
Compact and dynamic solution
for lower power ranges

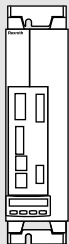

**Digital controller
IndraDrive Cs**
HCS 01
Compact and dynamic solution
for lower power ranges

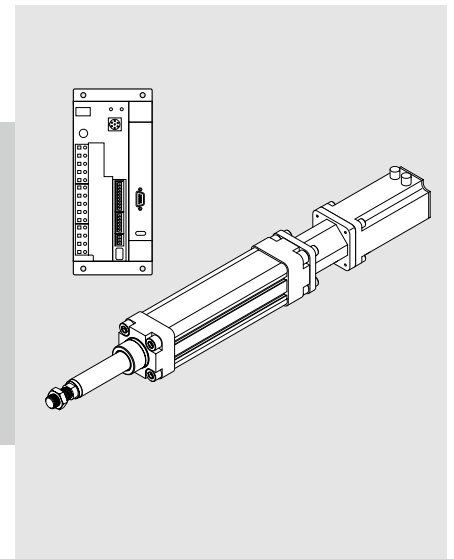

The Electromechanical Cylinders can be supplied complete with motor, controller and control unit.

Structural Design

- 1 Hex nut
- 2 Piston rod (stainless steel)
- 3 Round-neck nut (for attachment of mounting elements and motor attachments)
- 4 Magnet
- 5 Anti-twist feature
- 6 Ball screw
- 7 Angular-contact thrust ball bearing
- 8 Drive journal
- 9 T-slot for switches
- 10 Protective profile

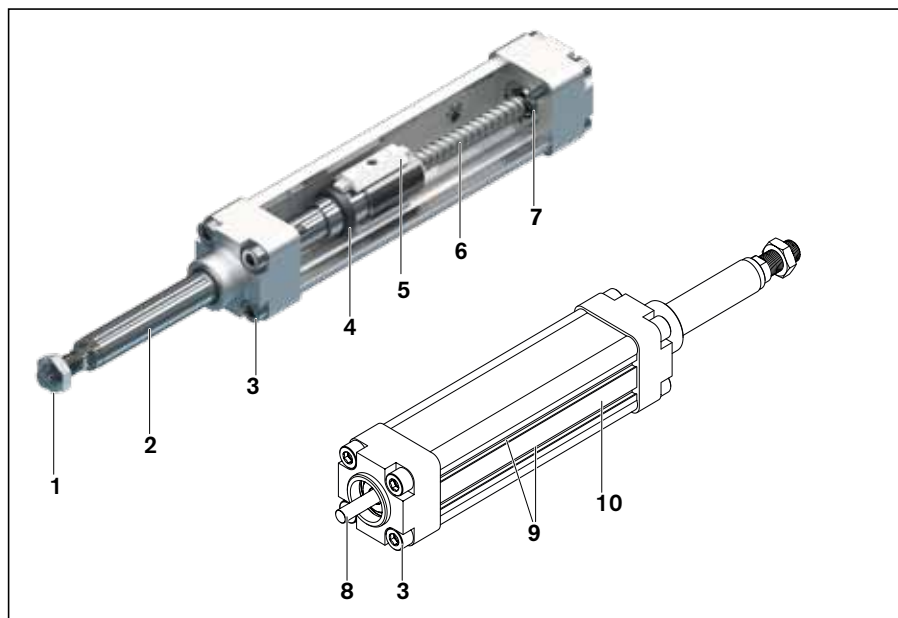

Attachments

- 11 Motor
- 12 Motor mount and coupling
- 13 Timing belt side drive

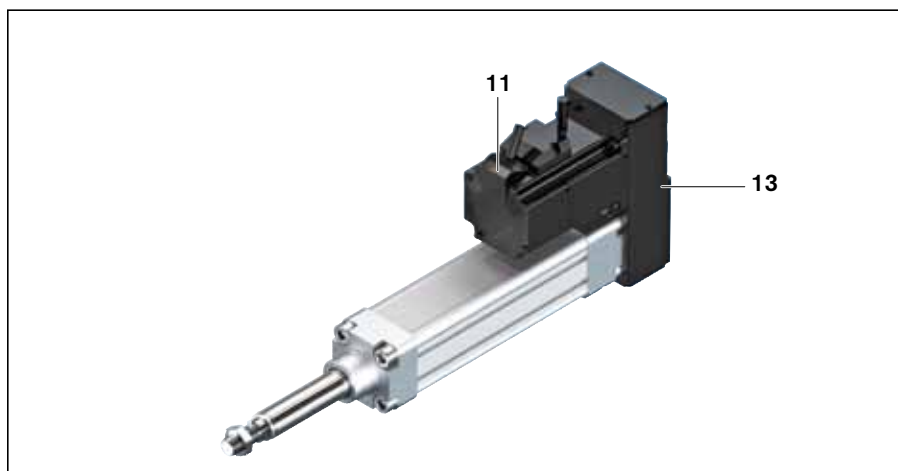
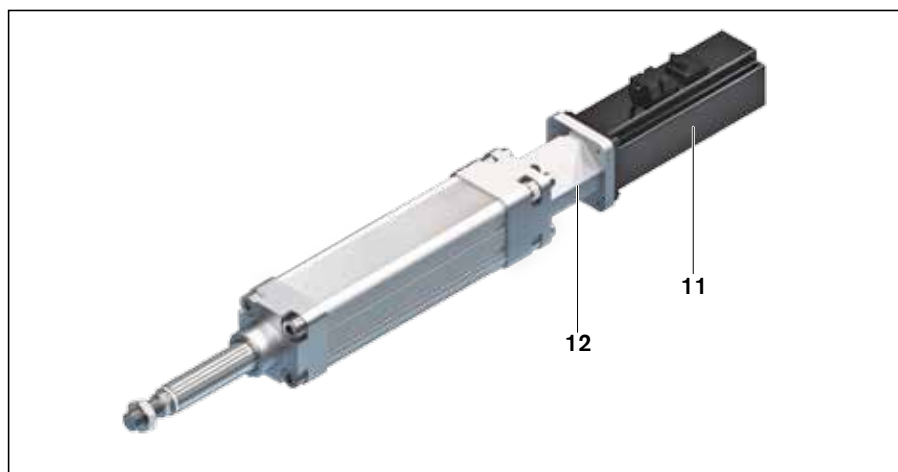

Technical Data and Dimensions EMC

Sizes 32 to 100 follow the standard cylinder series according to ISO 15552.

Built-in ball screw drives have a diameter of 12 mm to 40 mm.



The EMC size is selected according to:

- Thrust
- Stroke
- Linear speed

The actual values must be smaller than the maximum permissible values.

C_{EMC} = dynamic load rating of the EMC

d_0 = nominal diameter of ball screw

$F_{max EMC}$ = maximum load

M_p = max. drive torque at drive journal

P = ball screw lead

$s_{max perm.}$ = maximum permissible travel distance

v_{max} = max. permissible linear speed

Maximum travel distance s_{max} per customer specifications (minimum 100 mm)



EMC size	Ball screw		$C_{EMC}^{1)}$ (N)	$F_{max EMC}^{2)}$ (N)	$M_p^{2)}$ (Nm)	$v_{max}^{3)}$ (m/s)	$s_{max perm.}$ (mm)
	d_0 (mm)	P (mm)					
32	12	5	3800	580	0.51	0.57	750
	12	10	2500	440	0.78	1.13	750
40	16	5	12300	2800	2.46	0.38	750
	16	10	9600	2200	3.95	0.77	750
	16	16	9600	1700	4.87	1.23	750
50	20	5	14300	5800	5.09	0.32	900
	20	10	14100	4700	8.30	0.63	900
	20	20	13300	3100	11.08	1.27	900
63	25	5	15900	15900	14.06	0.28	1200
	25	10	15700	15700	27.76	0.55	1200
	25	25	14700	11900	52.44	1.38	1200
80	32	5	21600	19100	16.89	0.25	1500
	32	10	26000	17400	30.75	0.50	1500
	32	20	19700	13500	47.68	1.00	1500
	32	32	19500	10000	56.86	1.60	1500
100	40	5	29000	29000	25.64	0.18	1500
	40	10	29000	29000	51.28	0.37	1500
	40	20	29000	29000	102.57	0.73	1500
	40	40	29000	22900	161.46	1.47	1500

1) Acceptable loads (recommended from experience):

With respect to the desired service life, loads up to about 20% of the load rating have proved acceptable.

2) The achievable values may vary depending on the version, mounting orientation and maximum travel range s_{max} ! Charts page 24.

3) Depends on s_{max} ! Charts page 22.

Operating conditions

Normal operating conditions	
Ambient temperature	0 °C ... 50 °C
Load	See Technical Data
Duty cycle	100%

Technical Data and Dimensions EMC

EMC size	Ball screw		Weight (kg)	Total axial backlash ¹⁾ for		Frictional torque M_{RS} (Nm)	Constants ²⁾		
	d_0 (mm)	P (mm)		Ball nut with reduced backlash (mm)	Ball nut with 2% preload (mm)		$k_{j\text{ fix}}$	$k_{j\text{ var}}$	$k_{j\text{ m}}$
32	12	5	$0.869 + 0.003 \cdot s_{\text{max}}$	0.020	0.010	0.135	1.942	0.012	0.63300
	12	10	$0.887 + 0.003 \cdot s_{\text{max}}$	0.025	0.015	0.165	2.377	0.013	2.53303
40	16	5	$1.233 + 0.004 \cdot s_{\text{max}}$	0.030	0.010	0.260	9.437	0.032	0.63300
	16	10	$1.301 + 0.004 \cdot s_{\text{max}}$	0.035	0.015	0.300	10.257	0.033	2.53303
	16	16	$1.430 + 0.004 \cdot s_{\text{max}}$	0.040	0.020	0.350	12.335	0.040	6.48456
50	20	5	$2.062 + 0.006 \cdot s_{\text{max}}$	0.025	0.005	0.330	25.371	0.085	0.63300
	20	10	$1.919 + 0.006 \cdot s_{\text{max}}$	0.030	0.010	0.390	26.516	0.088	2.53303
	20	20	$2.468 + 0.006 \cdot s_{\text{max}}$	0.040	0.020	0.510	30.742	0.095	10.13210
63	25	5	$2.971 + 0.008 \cdot s_{\text{max}}$	0.025	0.005	0.450	60.788	0.223	0.63300
	25	10	$3.318 + 0.008 \cdot s_{\text{max}}$	0.030	0.010	0.545	76.223	0.256	10.13200
	25	25	$3.866 + 0.008 \cdot s_{\text{max}}$	0.040	0.020	0.770	80.765	0.249	15.83140
80	32	5	$5.207 + 0.013 \cdot s_{\text{max}}$	0.025	0.005	0.705	160.373	0.607	0.63300
	32	10	$6.170 + 0.013 \cdot s_{\text{max}}$	0.030	0.010	0.855	172.111	0.647	2.53303
	32	20	$6.430 + 0.013 \cdot s_{\text{max}}$	0.030	0.010	0.955	196.083	0.665	10.13210
	32	32	$7.548 + 0.013 \cdot s_{\text{max}}$	0.040	0.020	1.125	242.697	0.684	25.93820
100	40	5	$8.139 + 0.020 \cdot s_{\text{max}}$	0.025	0.005	1.040	486.375	1.568	0.63300
	40	10	$8.946 + 0.020 \cdot s_{\text{max}}$	0.040	0.005	1.320	455.882	1.369	2.53303
	40	20	$9.799 + 0.020 \cdot s_{\text{max}}$	0.045	0.010	1.420	499.344	1.408	10.13210
	40	40	$12.443 + 0.020 \cdot s_{\text{max}}$	0.055	0.020	1.840	673.570	1.567	40.52850

1) Total axial backlash of EMC when new

2) For calculation of the mass moment of inertia

M_{RS} = frictional torque of system

$k_{j\text{ fix}}$ = constant for fixed-length portion of mass moment of inertia

$k_{j\text{ m}}$ = constant for mass-specific portion of mass moment of inertia

$k_{j\text{ var}}$ = constant for variable-length portion of mass moment of inertia

EMC with Rexroth mounting elements

For more information please refer to page 32-43.

 The permissible axial forces for the mechanical cylinder system are reduced when the Rexroth mounting elements are used. The actual load must not exceed the values in the table.

$$F < F_{\text{max EMC with Rexroth mounting elements}}$$



The maximum attainable forces of the EMC/motor combination can be determined by referring to the "Calculations" section.

EMC size	Ball screw $d_0 \times P$ (mm)	Max. axial force (N)	
		$F_{\text{max EMC}}^1$	$F_{\text{max EMC with Rexroth mounting elements}}$
32	12x5	580	580
	12x10	440	440
40	16x5	2800	2100
	16x10	2200	2100
	16x16	1700	1700
50	20x5	5800	3400
	20x10	4700	3400
	20x20	3100	3100
63	25x5	15900	5000
	25x10	15700	5000
	25x25	11900	5000
80	32x5	19100	8000
	32x10	17400	8000
	32x20	13500	8000
	32x32	10000	8000
100	40x5	29000	12000
	40x10	29000	12000
	40x20	29000	12000
	40x40	22900	12000

1) $F_{\text{max EMC}}$ = maximum load

Shown in a retracted position

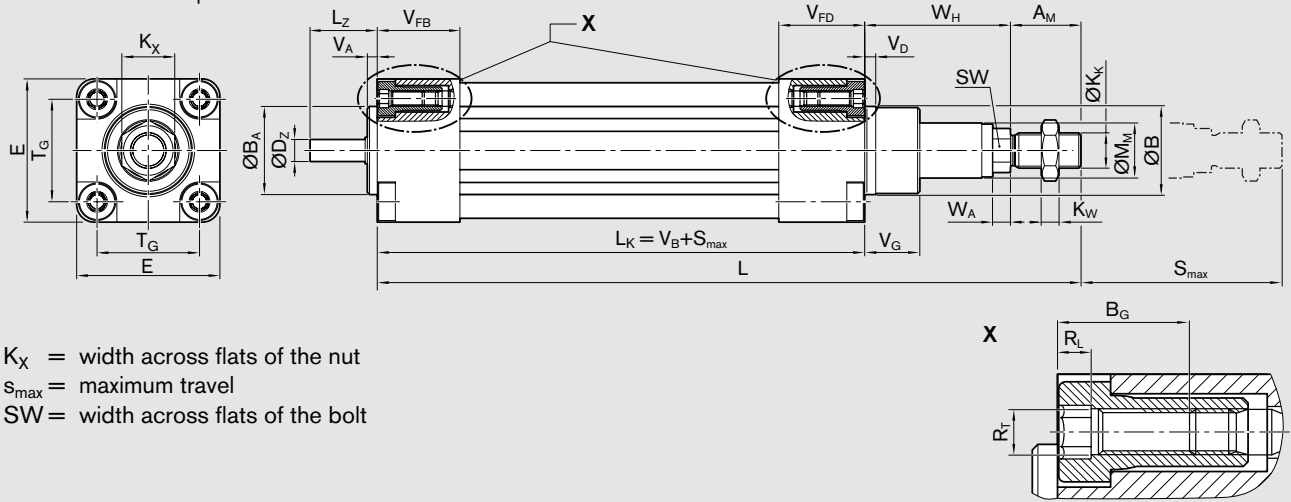

K_X = width across flats of the nut
 S_{max} = maximum travel
 SW = width across flats of the bolt

EMC size	Dimensions (mm)																			
	B d11	B _A d11	B _G	D _Z h7	E ± 0.1	K _K	K _W	K _X	L _Z	M _M f8	R _T	R _L	SW	T _G	V _A ± 0.1	V _D	V _{FB}	V _{FD}	V _G ± 0.1	W _A
32	30	30	16	5	47	M10x1.25	6	17	18	18	M6	4	10	32.5 ± 0.35	4	5	30	30	16	6
40	35	35	16	8	53	M12x1.25	7	19	25	20	M6	4	13	38.0 ± 0.35	4	5	33	30	20	6
50	40	40	16	10	65	M16x1.5	8	24	30	25	M8	4	17	46.5 ± 0.45	4	5	38	33	25	8
63	45	45	16	15	75	M16x1.5	8	24	35	30	M8	4	17	56.5 ± 0.55	4	5	40	33	25	8
80	55	55	16	18	95	M20x1.5	10	30	46	38	M10	0	22	72.0 ± 0.60	4	5	44	35	33	10
100	65	65	16	25	115	M20x1.5	10	30	57	50	M10	0	22	89.0 ± 0.60	4	5	48	35	38	10

EMC length

EMC size	Ball screw size	Dimensions (mm)		
		A _M -0.1	V _B	W _H
32	12x5Rx2-4	22	132	33
	12x10Rx2-2	22	136	33
40	16x5Rx3-4	24	134	37
	16x10Rx3-3	24	143	37
	16x16Rx3-3	24	159	37
50	20x5Rx3-4	32	142	44
	20x10Rx3-4	32	161	44
	20x20Rx3.5-3	32	180	44
63	25x5Rx3-4	32	148	44
	25x10Rx3-4	32	167	44
	25x25Rx3.5-3	32	199	44
80	32x5Rx3.5-4	40	163	54
	32x10Rx3.969-5	40	187	54
	32x20Rx3.969-3	40	195	54
	32x32Rx3.969-3	40	230	54
100	40x5Rx3.5-5	40	171	59
	40x10Rx6-4	40	185	59
	40x20Rx6-3	40	203	59
	40x40Rx6-3	40	258	59

$$L_K = V_B + s_{max}$$

 s_{max} = maximum travel (mm)

$$L = L_K + A_M + W_H$$

Maximum travel = effective stroke + 2 · excess travel

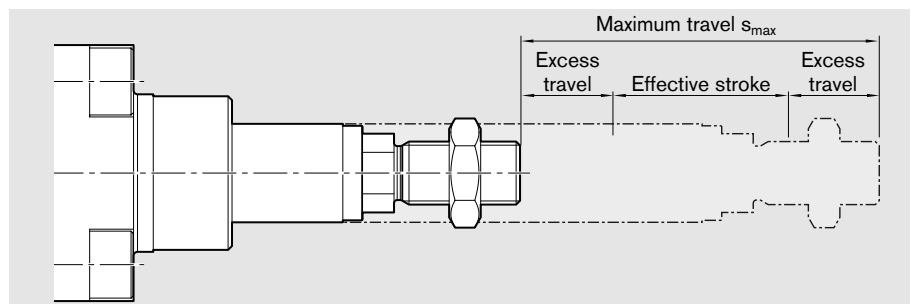

For safe operation, the excess travel must be longer than the braking distance.
 The acceleration travel can be taken as a guideline value for the braking distance.

In most cases, this will be sufficient: Excess travel = 2 · screw lead (P)

Example: Ball screw ($d_0 \times P$) 12x5: Excess travel = 2 · 5 mm = 10 mm

Maximum travel distance s_{max} per customer specifications (minimum 100 mm)

EMC with Motor Mount and Coupling

The motor mount serves to fasten the motor to the EMC and acts as a closed housing for the coupling. The coupling transmits the motor drive torque free of distortive stresses to the EMC's ball screw journal.

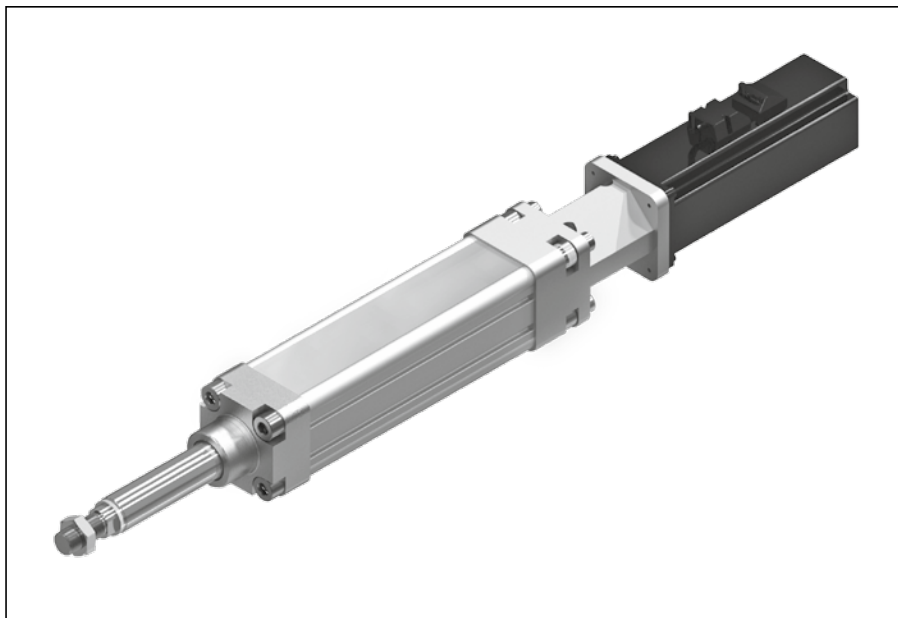

⚠ When an EMC is ordered with motor mount, motor and foot mounting, this will be delivered pre-assembled. If the foot mounting is to be retrofitted to the cylinder end cap, the motor mount has to be removed first.

For more information, see "Mounting Instructions for EMC," R320103103

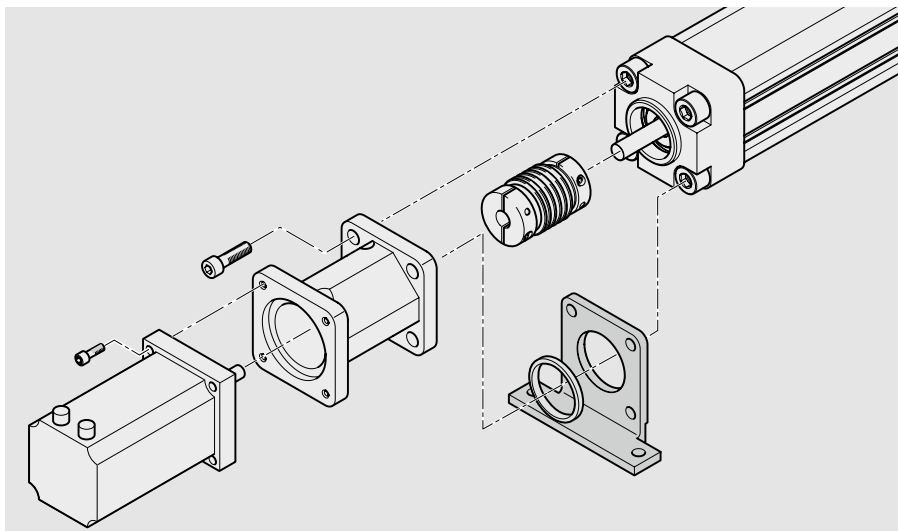

Mounting orientation of motor mount and coupling

- 1 Lube fitting on EMC
- 2 T-slots for switches on EMC
- 3 Motor connector

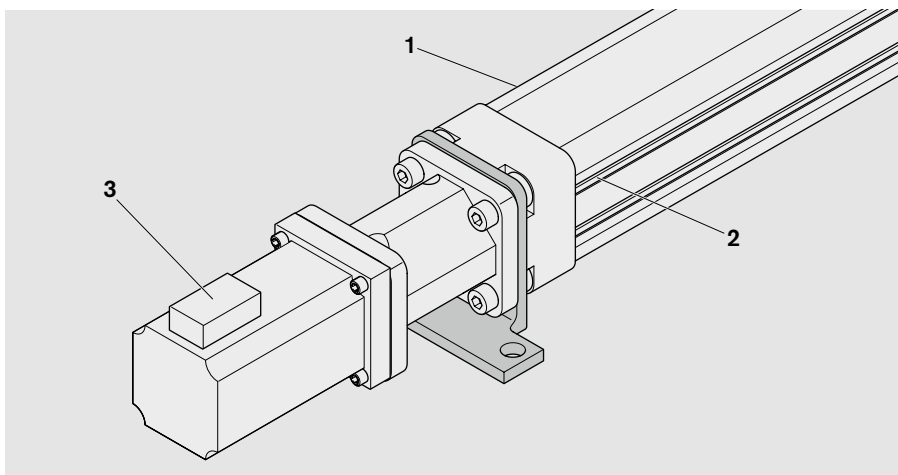

Shown in a retracted position

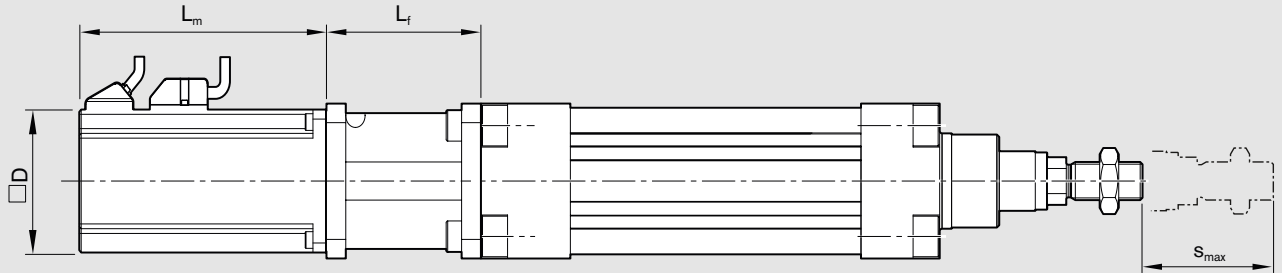
 S_{max} = maximum travel

EMC size	Motor	Coupling Mass moment of inertia	Rated torque	Mass of motor mount and coupling	Dimensions (mm)						
					J_c ($\times 10^{-6}$ kgm ²)	M_{cN} (Nm)	m (kg)	D	L_f		L_m
									without brake	with brake	
32	MSM 019B	2.1	1.9	0.15	38	45	92.0	122.0			
	MSM 031B	7.0	3.7	0.22	60	55	79.0	115.5			
	MSK 030C	7.0	3.7	0.22	54	55	188.0	213.0			
40	MSM 019B	2.1	1.9	0.19	38	52	92.0	122.0			
	MSM 031B	35.0	10.0	0.32	60	61	79.0	115.5			
	MSK 030C	35.0	10.0	0.30	54	61	188.0	213.0			
50	MSM 031B	63.0	14.5	0.53	60	73	98.5	135.0			
	MSK 030C	63.0	14.5	0.48	54	73	188.0	213.0			
	MSK 040C	63.0	14.5	0.67	82	73	185.0	215.5			
63	MSM 041B	64.0	19.0	0.84	80	73	112.0	149.0			
	MSK 040C	64.0	19.0	0.88	82	73	185.0	215.5			
	MSK 050C	64.0	19.0	0.92	98	78	203.0	233.0			
80	MSK 040C	63.0	14.5	1.21	82	78	185.0	215.5			
	MSK 050C	210.0	74.0	1.80	98	95	203.0	233.0			
	MSK 060C	210.0	74.0	2.00	116	100	226.0	259.0			
	MSK 076C	210.0	74.0	2.30	140	100	292.5	292.5			
100	MSK 060C	410.0	155.0	2.85	116	108	226.0	259.0			
	MSK 076C	410.0	155.0	3.15	140	108	292.5	292.5			

EMC with Belt Side Drive

This configuration of the EMC results in the shortest possible installation length. The compact, closed housing protects the belt, secures the motor and serves as a base for fastening mounting elements.

The following gear ratios are available:

$i = 1 : 1$

$i = 1 : 1.5$

$i = 1 : 2$

The timing belt side drive can be mounted in three different directions (RV01 to RV03).

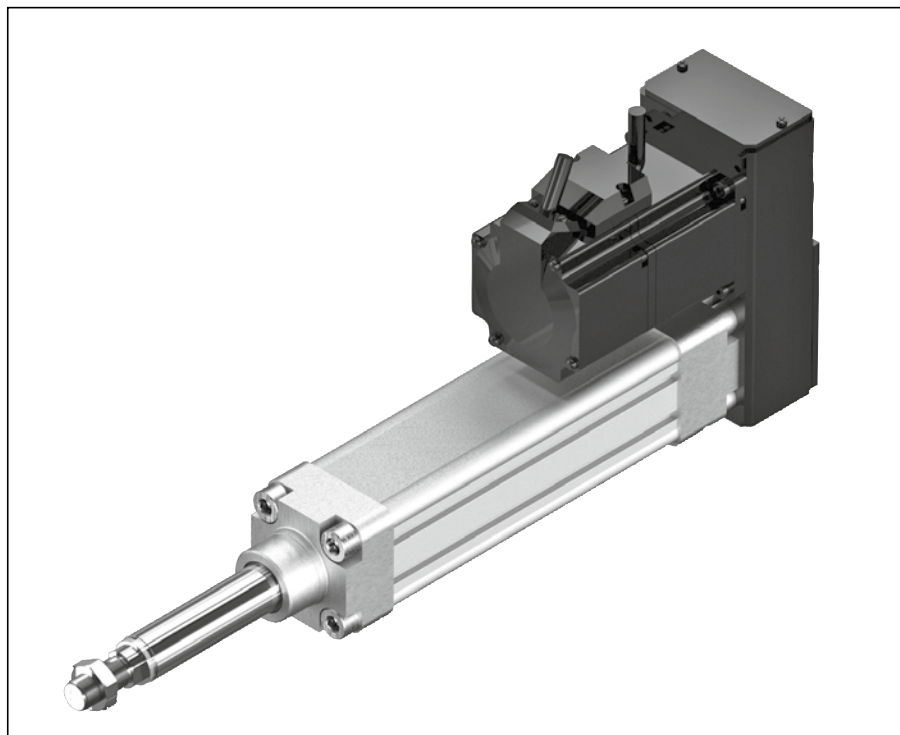

Mounting elements are attached at the rear end of the belt drive. The screws are included in the delivery of the mounting elements.

Before attaching the mounting elements, remove the set screws from the timing belt side drive.

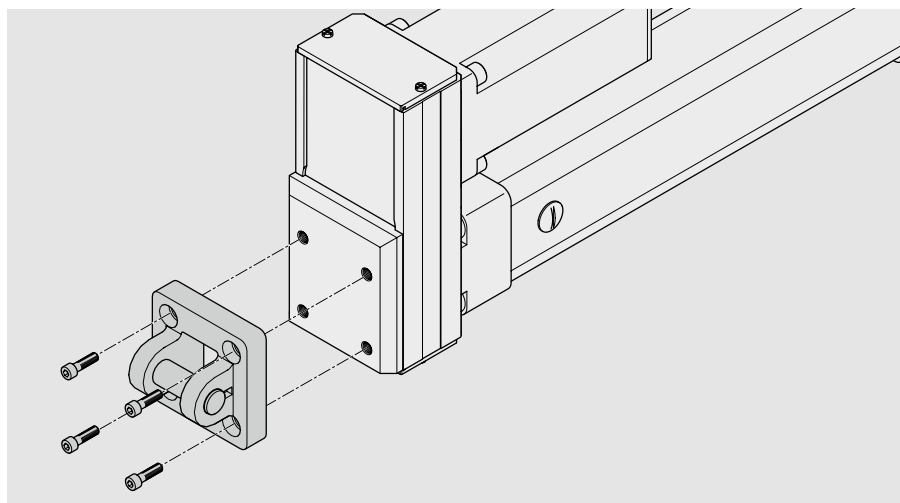

Mounting orientations for the timing belt side drive

- 1 Lube fitting on EMC
- 2 Motor connector

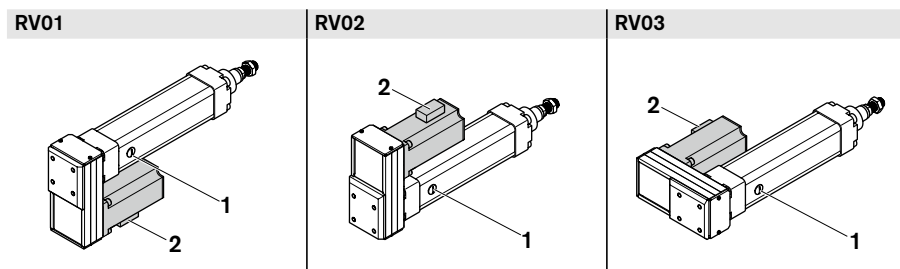

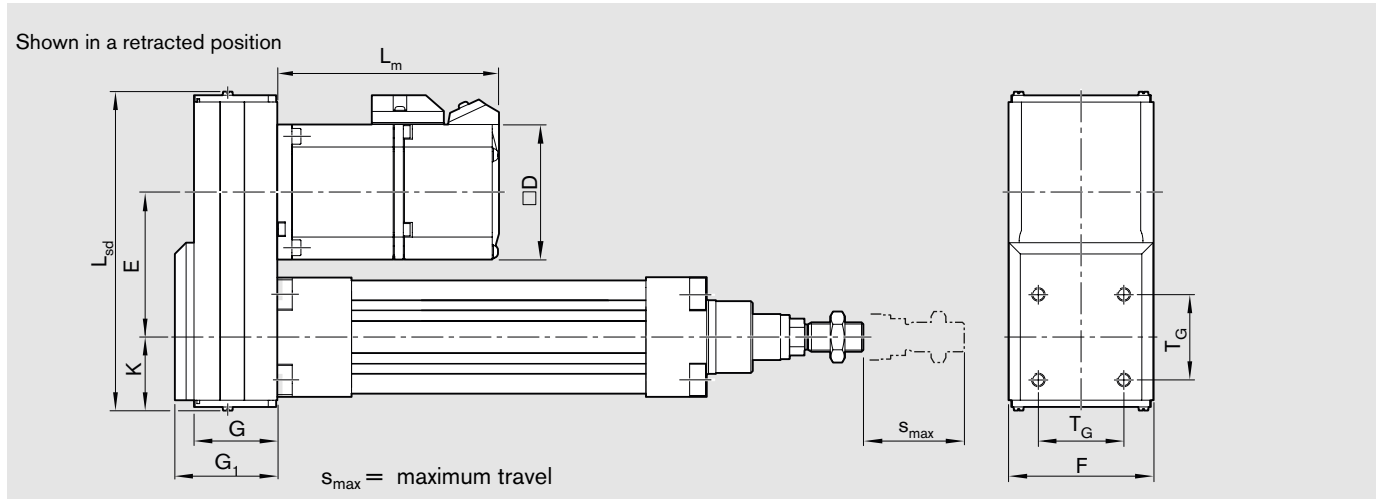

EMC size	Motor	Reduction i	Timing belt side drive Type ¹⁾	J _{sd} (·10 ⁻⁶ kgm ²)	M _{Rsd} (Nm)	m _{sd} (kg)	Dimensions (mm)										D	Brake		L _m														
							E	L _{sd}	F	G	G ₁	K	T _G	M	T _M	w/o		with																
32	MSM 019B	1	A	12.0	0.08	0.37	67.5	133	48.0	27.5	37.0	30.5	32.5	M6	16	38	92.0	122.0																
	MSM 031B	1	B	36.0	0.10	0.64	63.0	143	64.5	37.0	45.5	33.0				60	79.0	115.5																
	MSK 030C	1	B	35.0	0.10	0.65										54	188.0	213.0																
40	MSM 031C	1	A	36.0	0.15	0.70	63.0	143	64.5	37.0	45.5	33.0	38.0	M6	16	60	98.5	135.0																
		1.5	A	13.0	0.15	0.62	65.5									60	98.5	135.0																
	MSK 030C	1	A	36.0	0.15	0.70	63.0									54	188.0	213.0																
	MSK 040C	1	B	230.0	0.30	1.50	82.5									82	185.0	215.5																
		1.5	B	82.0	0.30	1.40	81.5																											
50	MSM 031C	1	A	230.0	0.35	1.35	82.5	174	88.0	51.0	55.5	44.0	46.5	M8	16	60	98.5	135.0																
		1.5	A	82.0	0.35	1.25	81.5									80	112.0	149.0																
	MSM 041B	1	A	230.0	0.35	1.50	82.5									191	88.0	51.0	55.5	44.0	46.5	M8	16	82	185.0	215.5								
		1.5	A	78.0	0.35	1.40	81.5																	82	185.0	215.5								
	MSK 040C	1	A	231.0	0.35	1.50	82.5																	98	203.0	233.0								
		1.5	A	82.0	0.35	1.40	81.5																											
	MSK 050C	1	B	1090.0	0.40	3.30	95.0																	234	116.0	66.0	77.0	56.0				98	203.0	233.0
63	MSM 041B	1	A	1040.0	0.45	2.80	95.0	219	116.0	66.0	77.0	56.0	56.5	M8	16	80	112.0	149.0																
		2	A	170.0	0.45	2.50	98.5									82	185.0	215.5																
	MSK 040C	1	A	1040.0	0.45	2.80	95.0									252	116.0	66.0	77.0	56.0	56.5	M8	16	98	203.0	233.0								
		2	A	180.0	0.45	2.50	98.5																	116	226.0	259.0								
	MSK 050C	1	B	1310.0	0.50	3.30	117.5																	257	116.0	66.0	77.0	56.0	72.0	M10	16	98	203.0	233.0
		2	B	220.0	0.50	2.90	116.5																									116	226.0	259.0
MSK 060C	1	B	1330.0	0.50	3.40	117.5	140	292.5	292.5																									
80	MSK 050C	1	A	1380.0	0.55	3.50	117.5	290	160.0	90.0	102.0	77.0	89.0	M10	16	98	203.0	233.0																
		2	A	240.0	0.55	3.10	116.5									116	226.0	259.0																
	MSK 060C	1	B	5040.0	0.70	6.80	130.0									299	160.0	90.0	102.0	77.0	89.0	M10	16									140	292.5	292.5
		2	B	830.0	0.70	6.00	126.0																	140	292.5	292.5								
100	MSK 060C	1	A	5160.0	0.70	6.90	130.0	324	160.0	90.0	102.0	77.0	89.0	M10	16									116	226.0	259.0								
		2	A	860.0	0.70	6.10	126.0																	140	292.5	292.5								
	MSK 076C	1	B	7650.0	1.00	8.50	150.0									324	160.0	90.0	102.0	77.0	89.0	M10	16	140	292.5	292.5								
		2	B	1260.0	1.00	7.40	151.5																	140	292.5	292.5								

J_{sd} Mass moment of inertia of timing belt side drive (at motor journal)
M_{Rsd} Frictional torque of timing belt side drive
m_{sd} Mass of the timing belt side drive
M_{sd} Maximum permissible drive torque of the timing belt side drive ! Table page 25

1) See page 25, Table for drive torque according to lead and SD type

Permissible Speeds

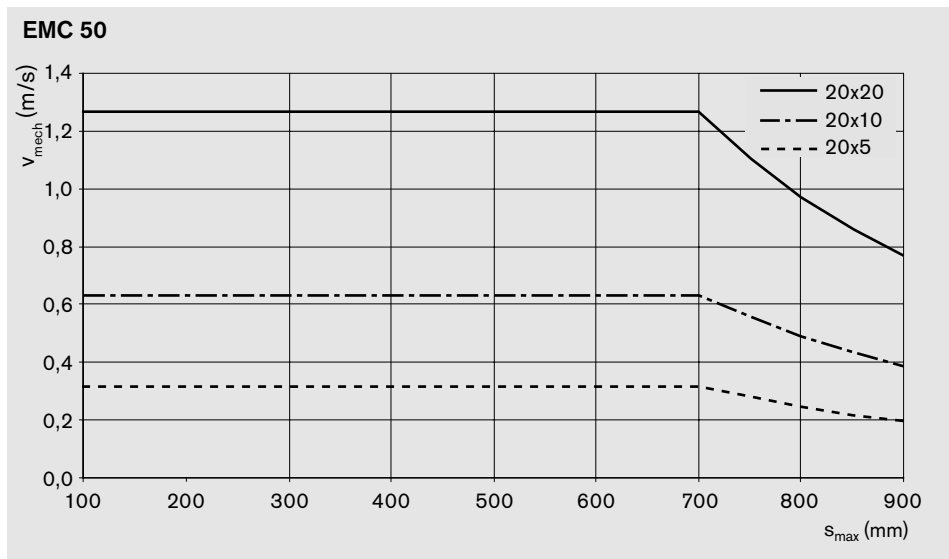
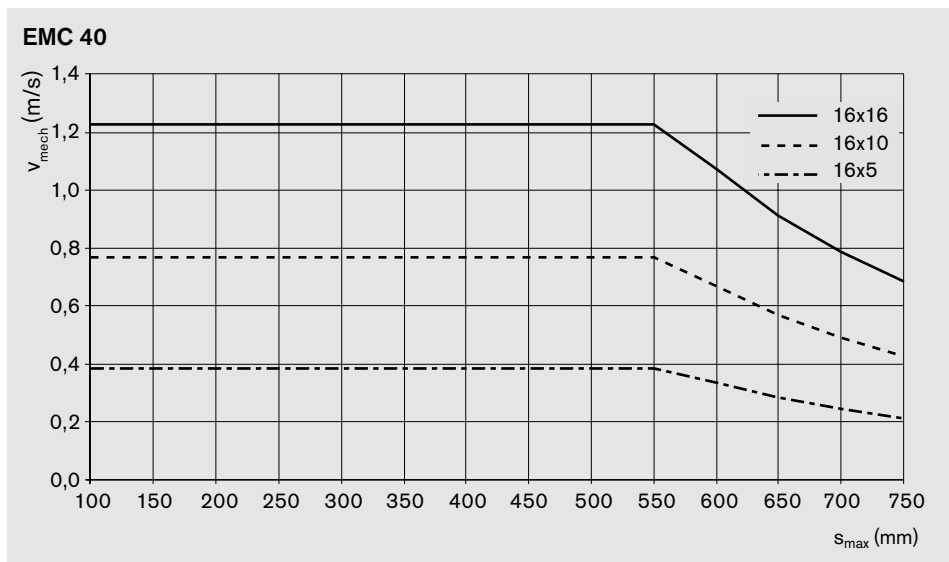
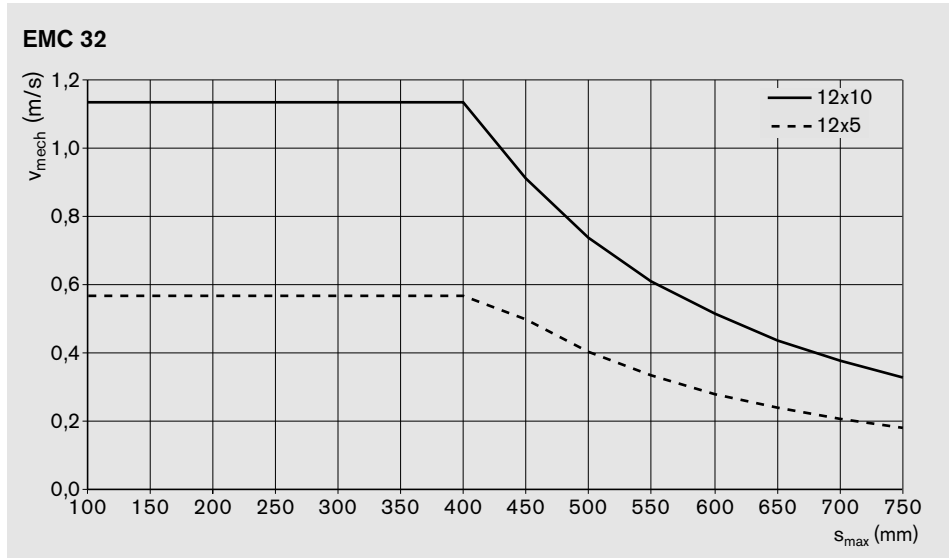

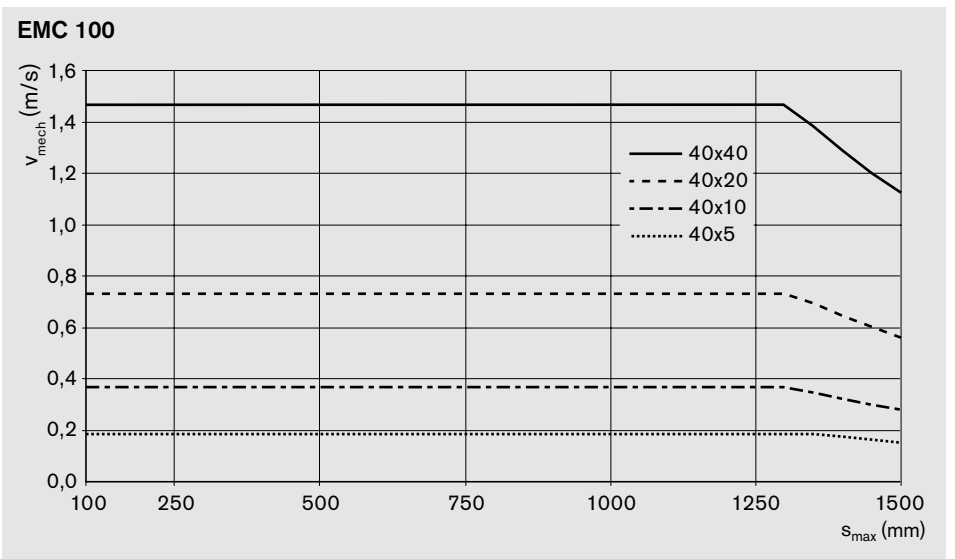
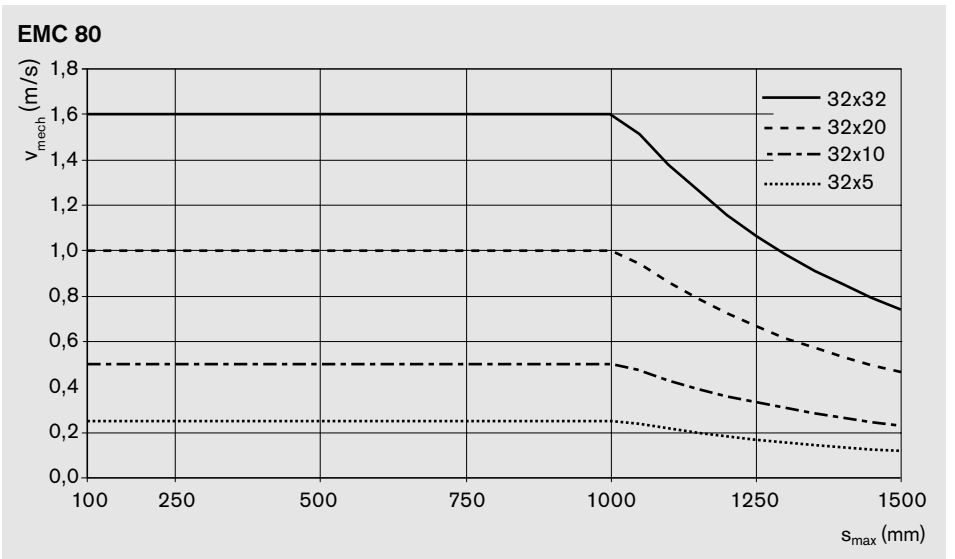
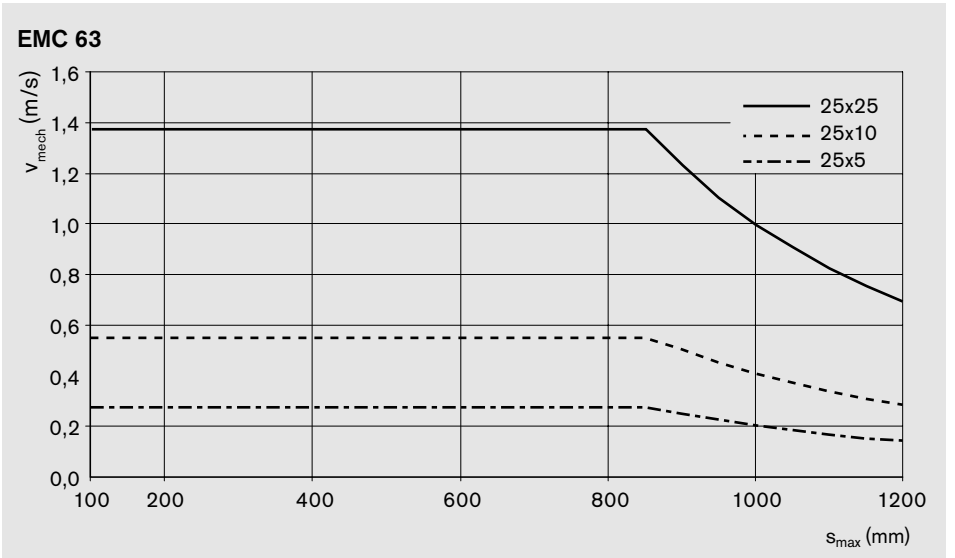

Permissible Drive Torque M_p

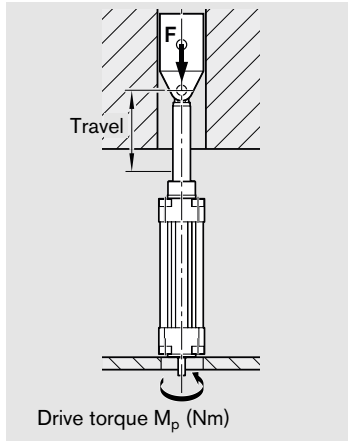

The attainable torques may vary according to the EMC version and the type of mounting.

Case I

Fixed mounting to head and end cap (flange or foot mounting).

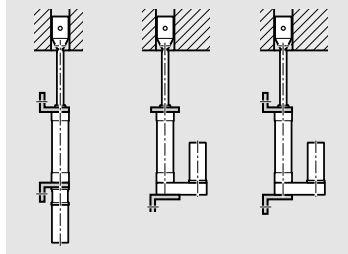

Case II

Fixed mounting to head cap or end cap (flange or foot mounting).

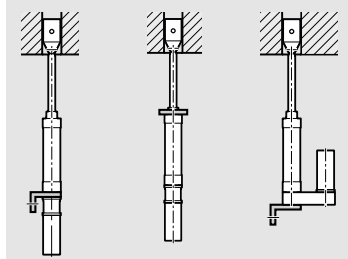

Case III

All types of articulated mounting. Pivotable or swivel mountings.

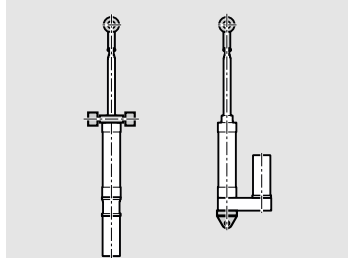

EMC 32

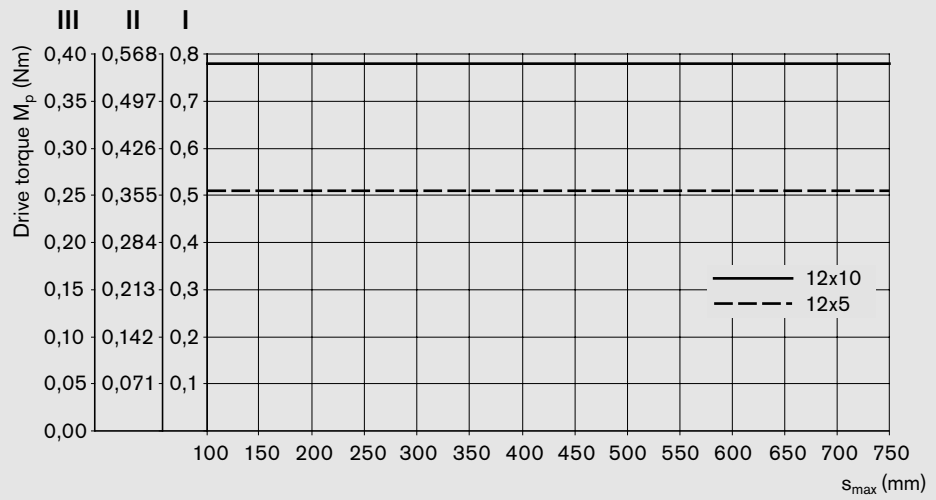

EMC 40

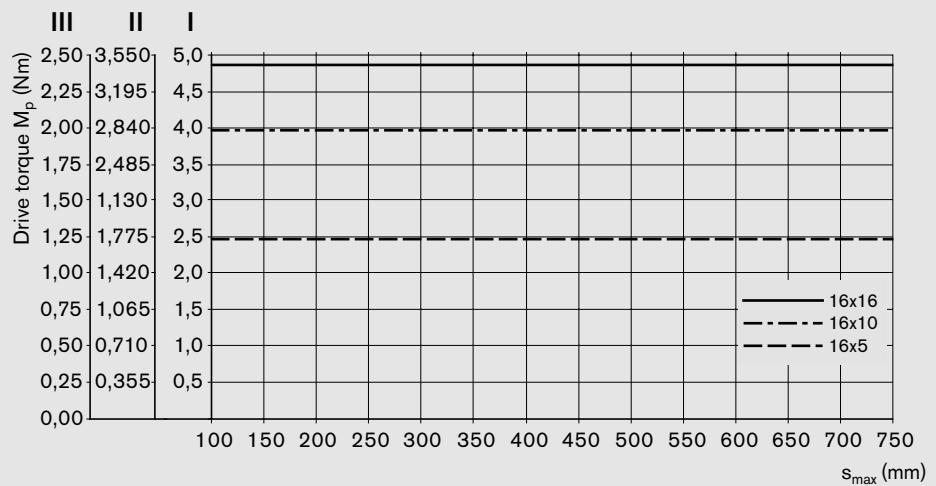

EMC 50

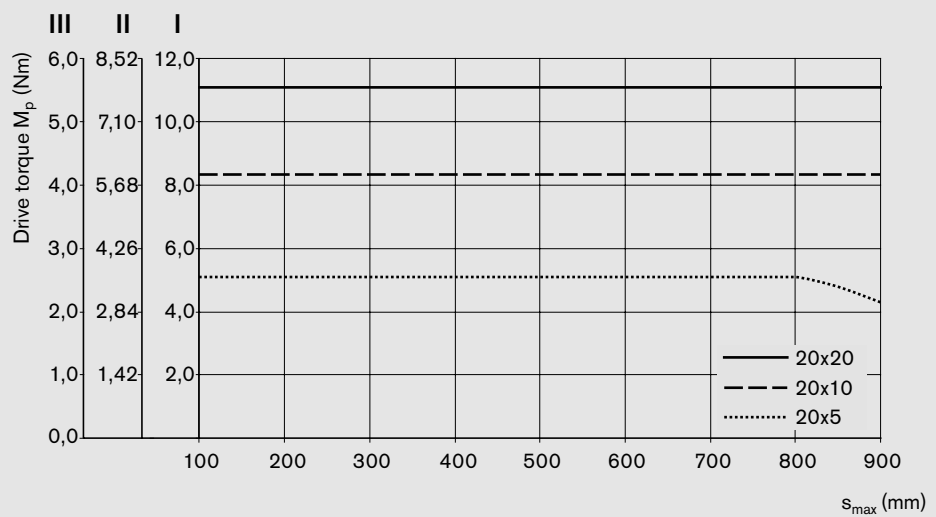

Motor attachment with timing belt side drive:

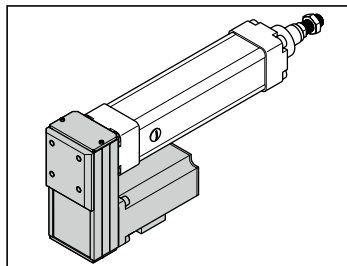

For motor attachment with timing belt side drive (SD), the drive torque at the EMC journal may be limited depending on the version:

EMC	Type	Ball screw lead P (mm)							
		RV	5	10	16	20	25	32	40
32	A	-	-						
	B	-	-						
40	A	-	3.2	3.2					
	B	-	-	-					
50	A	-	-		8.2				
	B	-	-		-				
63	A	-	18.5			18.5			
	B	-	22			23.5			
80	A	-	24		24		24		
	B	-	28		38		42		
100	A	-	-		55			55	
	B	-	-		80			80	

When comparing the chart and table, the permissible drive torque is always the lower of the two values.

Example:

EMC 100, ball screw 40x20, $s_{max} = 700$ mm,

motor attachment with timing belt side drive

Type B:

- From chart $M_p = 102$ Nm
- From table $M_p = 80$ Nm

! permissible drive torque at EMC journal: $M_p = 80$ Nm

EMC 63

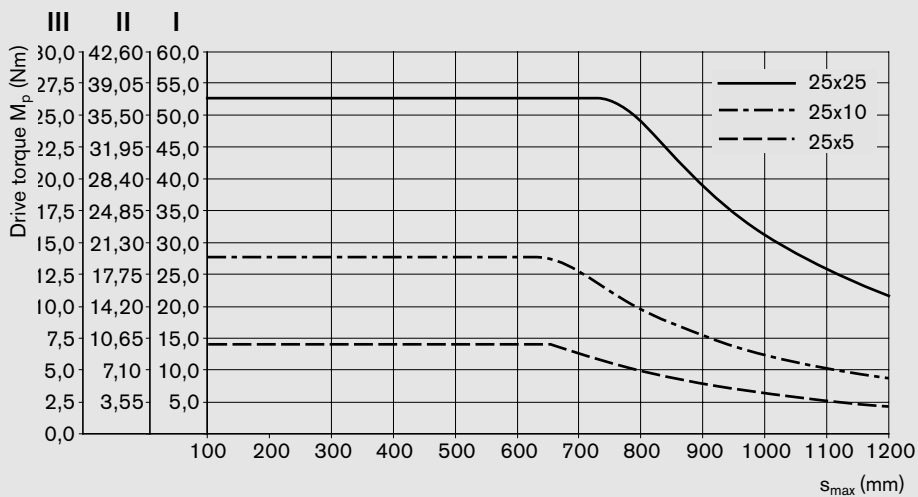

EMC 80

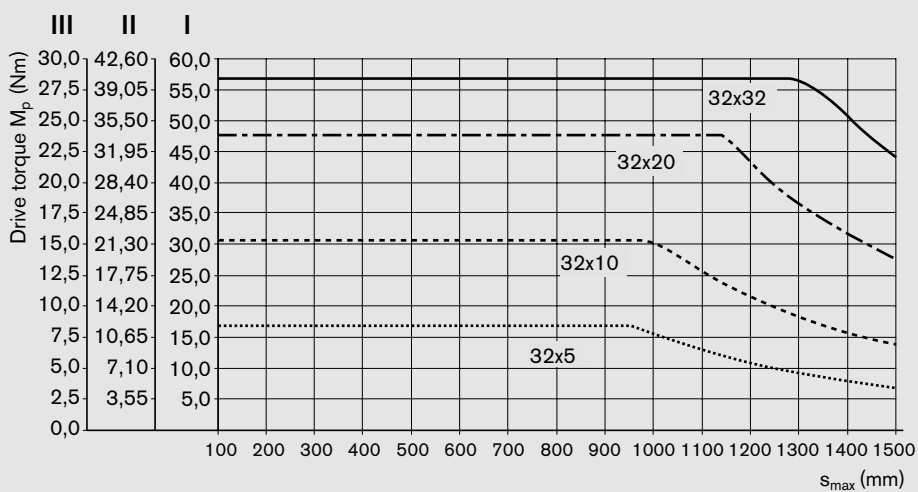

EMC 100

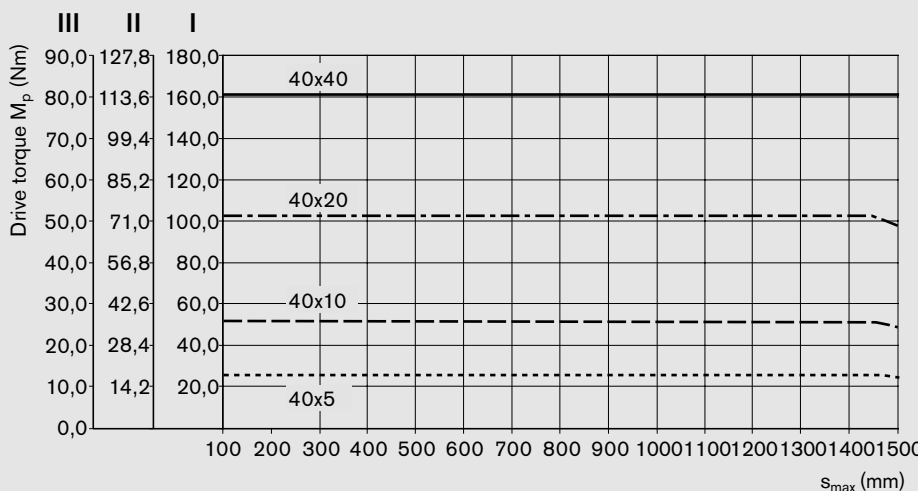

Maximum Axial Loading of Mechanical Cylinder System F_{max}

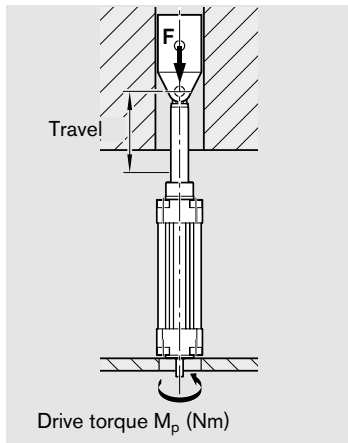

The attainable forces may vary according to the type of mounting.

Case I

Fixed mounting to head and end cap (flange or foot mounting).

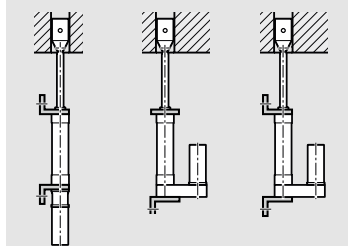

Case II

Fixed mounting to head cap or end cap (flange or foot mounting).

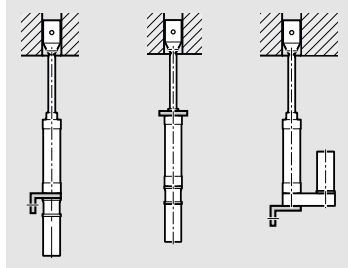

Case III

All types of articulated mounting. Pivotal or swivel mountings.

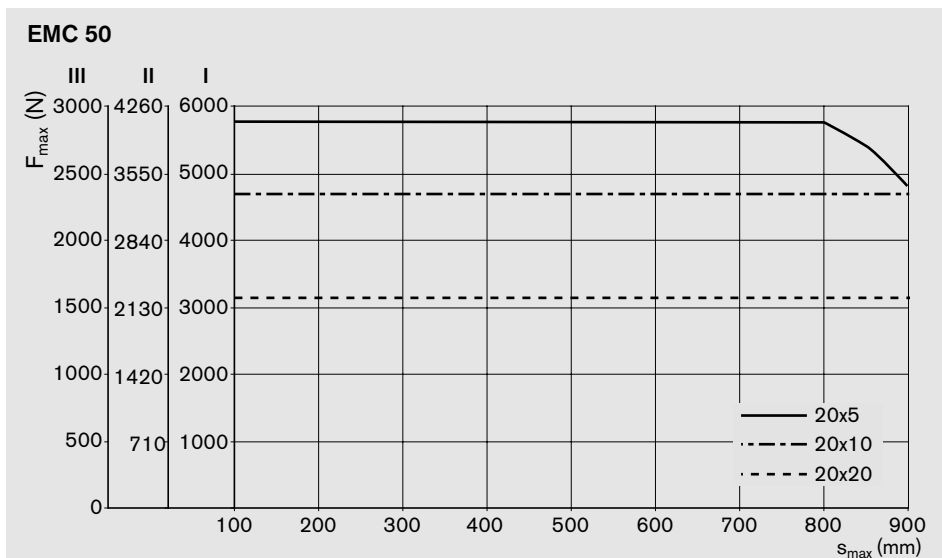
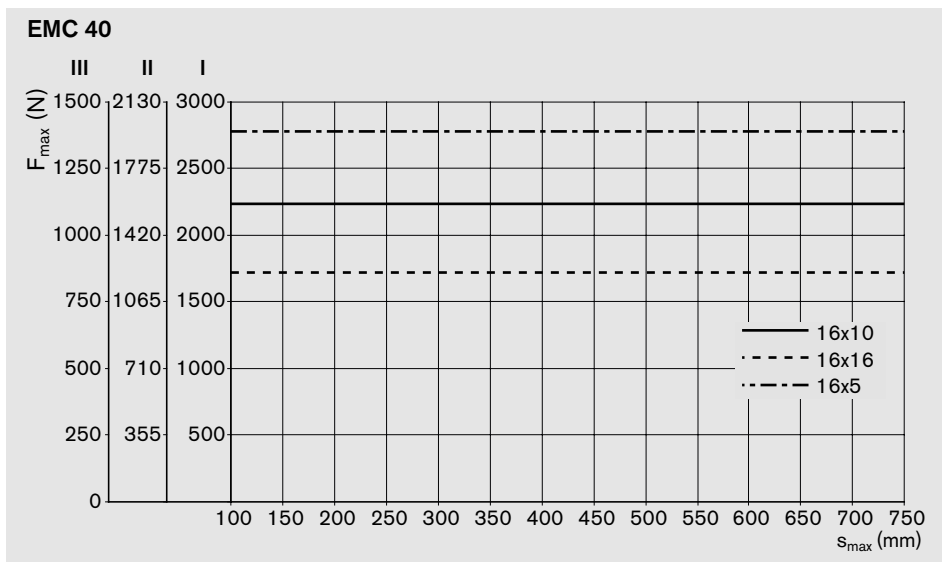
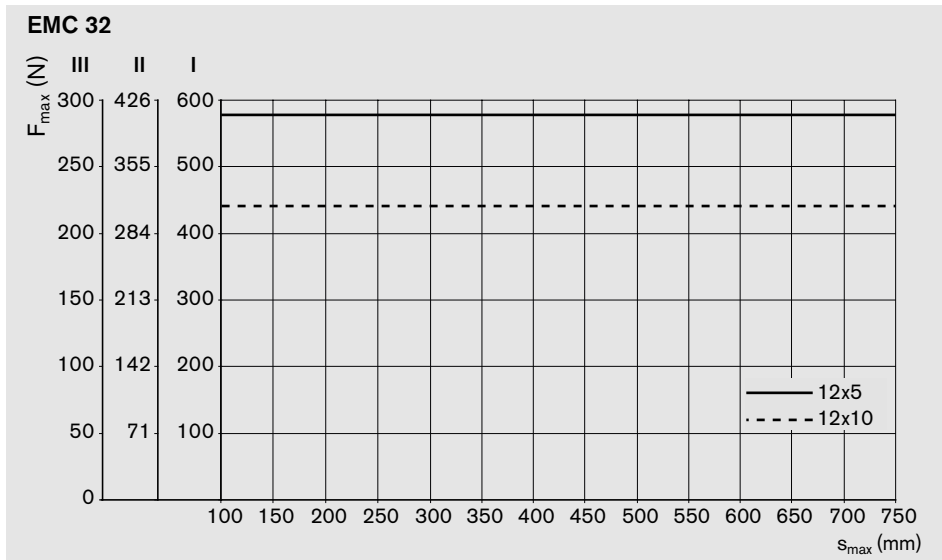
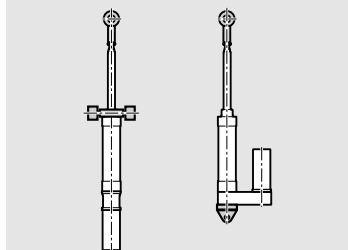

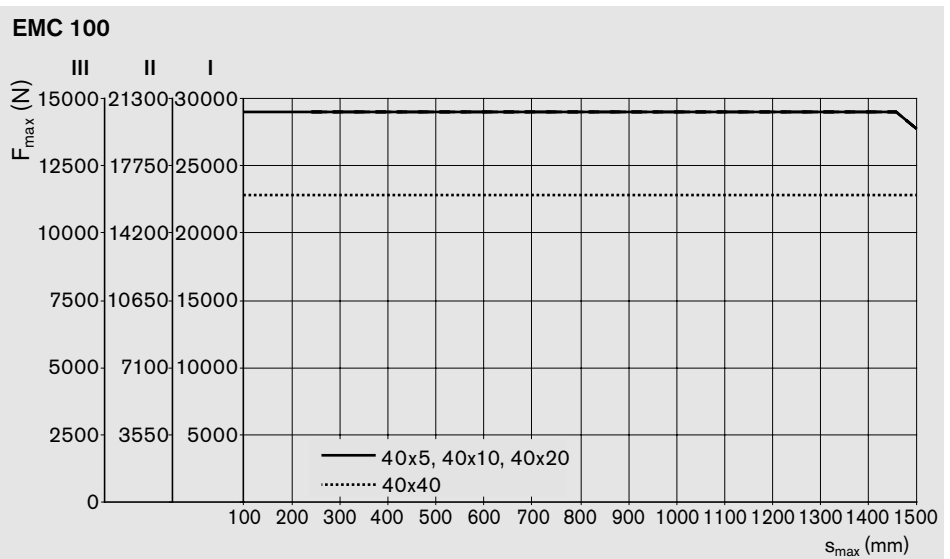
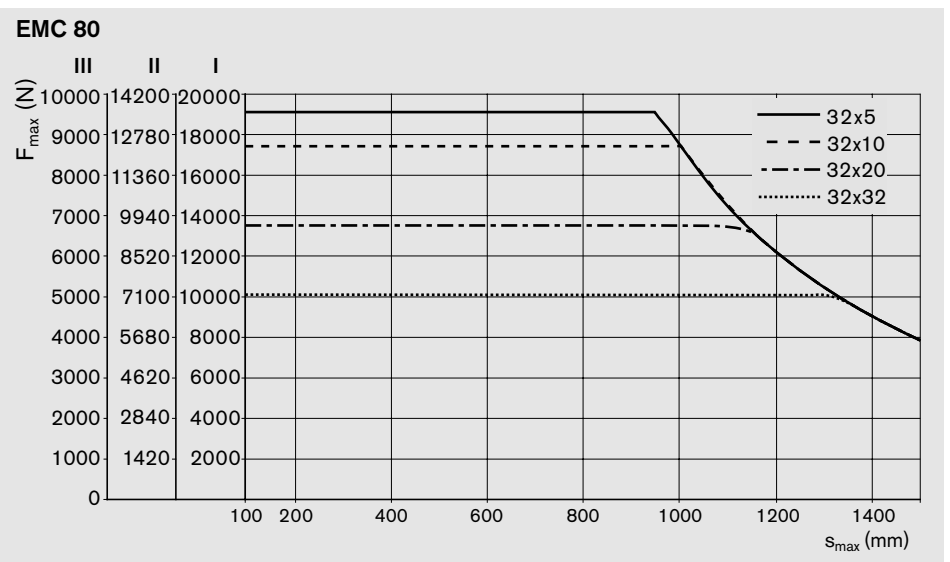
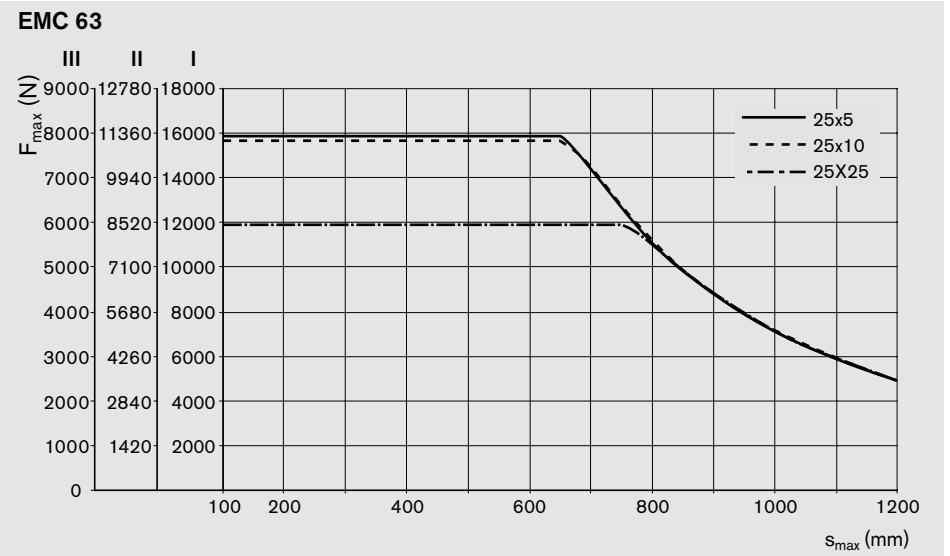

Calculations

After pre-selection of the mechanical cylinder system, the mounting elements and the cylinder/motor combination, the calculations can now be performed.

The actual loads must be smaller than the maximum permissible loads for the mechanical cylinder system and the mounting elements.

Average speed and average load

- where the speed fluctuates, the average speed n_m is calculated as follows

$$n_m = \frac{q_1}{100} \cdot n_1 + \frac{q_2}{100} \cdot n_2 + \dots + \frac{q_n}{100} \cdot n_n$$

- where the load fluctuates and the speed is constant, the equivalent dynamic axial load $F_{m,ax}$ is calculated as follows

$$F_{m,ax} = \sqrt[3]{F_1^3 \cdot \frac{q_1}{100} + F_2^3 \cdot \frac{q_2}{100} + \dots + F_n^3 \cdot \frac{q_n}{100}}$$

- where both the load and speed fluctuate, the equivalent dynamic axial load $F_{m,ax}$ is calculated as follows

$$F_{m,ax} = \sqrt[3]{F_1^3 \cdot \frac{n_1}{n_m} \cdot \frac{q_1}{100} + F_2^3 \cdot \frac{n_2}{n_m} \cdot \frac{q_2}{100} + \dots + F_n^3 \cdot \frac{n_n}{n_m} \cdot \frac{q_n}{100}}$$

$F_{m,ax}$ = equivalent dynamic axial load (N)
 n_m = average rotary speed (min^{-1})

calculated using the average values for $F_{m,ax}$ and n_m .

q = discrete time step for phases 1 ... n (%)

Nominal life

Service life in revolutions L

$$L = \left(\frac{C}{F_{m,ax}} \right)^3 \cdot 10^6 \Rightarrow C = F_{m,ax} \cdot \sqrt[3]{\frac{L}{10^6}} \Rightarrow F_{m,ax} = \sqrt[3]{\frac{C \cdot L}{10^6}}$$

C = dynamic load capacity (N)

$F_{m,ax}$ = equivalent dynamic axial load (N)

Service life in hours L_h

$$L_h = \frac{L}{n_m \cdot 60}$$

L_h = service life (h)

L = service life (revolutions) (-)

n_m = average rotary speed (min^{-1})

$$\text{Machine operating hours} = L_h \cdot \frac{\text{Machine duty cycle}}{\text{Screw duty cycle}}$$

Drive torque and drive power

Drive torque M_p

Conversion of rotary to linear motion:

$$M_p = \frac{F \cdot P}{2000 \cdot \pi \cdot \eta}$$

F = operating load (N)

M_p = drive torque (Nm)

P = lead (mm)

η = mechanical efficiency (≈ 0.9)

The dynamic drag torque must be taken into account for preloaded ball nut units.

Drive power P_a

$$P_a = \frac{M_p \cdot n}{9550}$$

M_p = drive torque (Nm)

n = rotary speed (min^{-1})

P_a = drive power (kW)

Frictional torque M_R

for motor attachment via motor mount and coupling:

$$M_R = M_{RS}$$

for motor attachment via timing belt side drive:

$$M_R = \frac{M_{RS}}{i} + M_{Rsd}$$

Mass moment of inertia J_s

of the EMC referred to the drive journal

$$J_s = (k_{J_{fix}} + k_{J_{var}} \cdot s_{max}) \cdot 10^{-6}$$

Mass moment of inertia J_{ex}

of the mechanical system referred to the motor journal

Motor attachment via motor mount and coupling

$$J_{ex} = J_s + J_t + J_c$$

Motor attachment via timing belt side drive

$$J_{ex} = \frac{J_s + J_t}{i^2} + J_{sd}$$

Translatory mass moment of inertia of external load J_t

referred to the drive journal

$$J_t = m_{ex} \cdot k_{Jm} \cdot 10^{-6}$$

Mass moment of inertia J_{dc}

of the drive train referred to the motor journal

$$J_{dc} = J_{ex} + J_{br}$$

Mass moment of inertia ratio V

$$V = \frac{J_{dc}}{J_m}$$

Application area	V
Handling	≤ 6.0
Processing	≤ 1.5

Total mass moment of inertia J_{tot}

referred to the motor journal

$$J_{tot} = J_{dc} + J_m$$

Maximum permissible rotary speed n_{mech}

of mechanical system

$$n_{mech} = \frac{v_{mech} \cdot i \cdot 1000 \cdot 60}{P}$$

$$n_{mech} < n_{mmax}$$

Effective stroke

$$\text{Effective stroke} = s_{max} - 2 \times \text{excess travel}$$

- i = gear ratio
- J_s = mass moment of inertia of EMC (without external load) (kgm²)
- $k_{J_{fix}}$ = constant for fixed-length portion of mass moment of inertia (10⁶ kgm²)
- $k_{J_{var}}$ = constant for variable-length portion of mass moment of inertia (10⁹ kgm)
- M_R = frictional torque at motor journal (Nm)
- M_{RS} = frictional torque of the system (Nm)
- M_{Rsd} = frictional torque of timing belt side drive at motor journal (Nm)
- s_{max} = maximum travel (mm)
- J_{br} = mass moment of inertia, motor brake (kgm²)
- J_c = mass moment of inertia, coupling (kgm²)
- J_{dc} = mass moment of inertia, drive train (kgm²)
- J_{ex} = mass moment of inertia of mechanical system (kgm²)
- J_m = mass moment of inertia, motor (kgm²)
- J_s = mass moment of inertia of EMC (without external load) (kgm²)
- J_{sd} = mass moment of inertia of timing belt side drive at motor journal (kgm²)
- J_t = translatory mass moment of inertia of external load referred to the drive journal (kgm²)
- J_{tot} = total mass moment of inertia (kgm²)
- i = gear ratio of timing belt side drive (-)
- k_{Jm} = constant for mass-specific portion of mass moment of inertia (10⁶ m²)
- m_{ex} = moved external load (kg)
- n_{mmax} = maximum permissible rotary speed of motor with controller (min⁻¹)
- n_{mech} = maximum permissible rotary speed of mechanical system (min⁻¹)
- P = screw lead (mm)
- V = ratio of mass moments of inertia of drive train and motor (-)
- v_{mech} = maximum permissible linear speed of mechanical system (m/s)

Switch Mounting Arrangements, Magnetic Field Sensor

Overview of the switching system

- 1 Switch (magnetic field sensor)
- 2 T-slot for switch
- 3 Magnet

⚠ For short-stroke applications:
Consider the length of the switch!

Magnetic field sensors with potted cables can be used with the EMC.

Version

- Sensor (PNP NC)

Notes for mounting

The magnetic field sensors (MFS) are pushed into the T-slot and fixed with set screws.

For more details on switch activation points and switch mounting arrangements, see the Instructions for “Electromechanical Cylinders EMC,” R320103103.

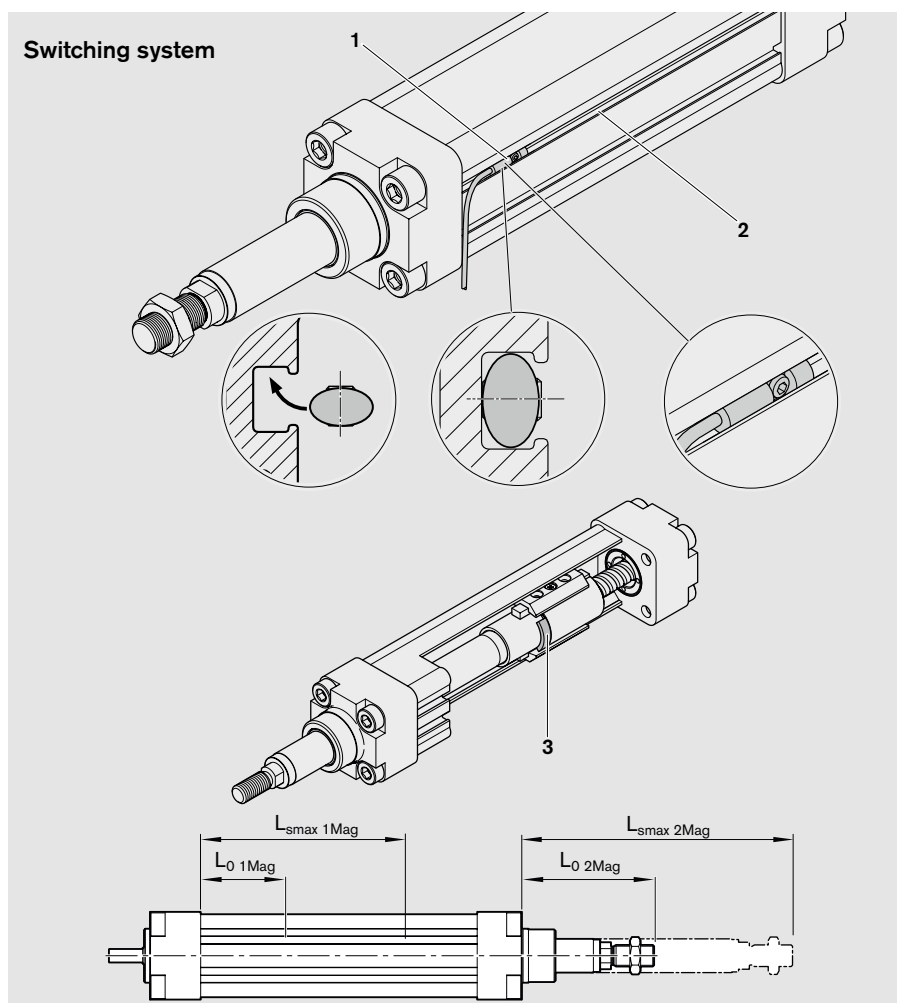

Switch position

The dimensions in the table indicate the position of the magnet as a function of the travel.

⚠ The unit must not travel beyond these positions! If it does, there is a risk that the ball nut may collide with the housing.

EMC size	Ball screw size $d_o \times P$ (mm)	Dimensions (mm)			
		At travel 0 mm		At travel s_{max} mm	
		L_0 1Mag	L_{smax} 1Mag	L_0 2Mag	L_{smax} 2Mag
32	12x5	42	55	$42+s_{max}$	$55+s_{max}$
	12x10	46	55	$46+s_{max}$	$55+s_{max}$
40	16x5	49	61	$49+s_{max}$	$61+s_{max}$
	16x10	58	61	$58+s_{max}$	$61+s_{max}$
50	16x16	74	61	$74+s_{max}$	$61+s_{max}$
	20x5	53	76	$53+s_{max}$	$76+s_{max}$
50	20x10	72	76	$72+s_{max}$	$76+s_{max}$
	20x20	91	76	$91+s_{max}$	$76+s_{max}$
63	25x5	57	76	$57+s_{max}$	$76+s_{max}$
	25x10	76	76	$76+s_{max}$	$76+s_{max}$
63	25x25	108	76	$108+s_{max}$	$76+s_{max}$
	32x5	63.5	94	$63.5+s_{max}$	$94+s_{max}$
80	32x10	90	94	$90+s_{max}$	$94+s_{max}$
	32x20	98	94	$98+s_{max}$	$94+s_{max}$
80	32x32	133	94	$133+s_{max}$	$94+s_{max}$
	40x5	67.5	99	$67.5+s_{max}$	$99+s_{max}$
100	40x10	84	99	$84+s_{max}$	$99+s_{max}$
	40x20	102	99	$102+s_{max}$	$99+s_{max}$
100	40x40	157	99	$157+s_{max}$	$99+s_{max}$

Technical data

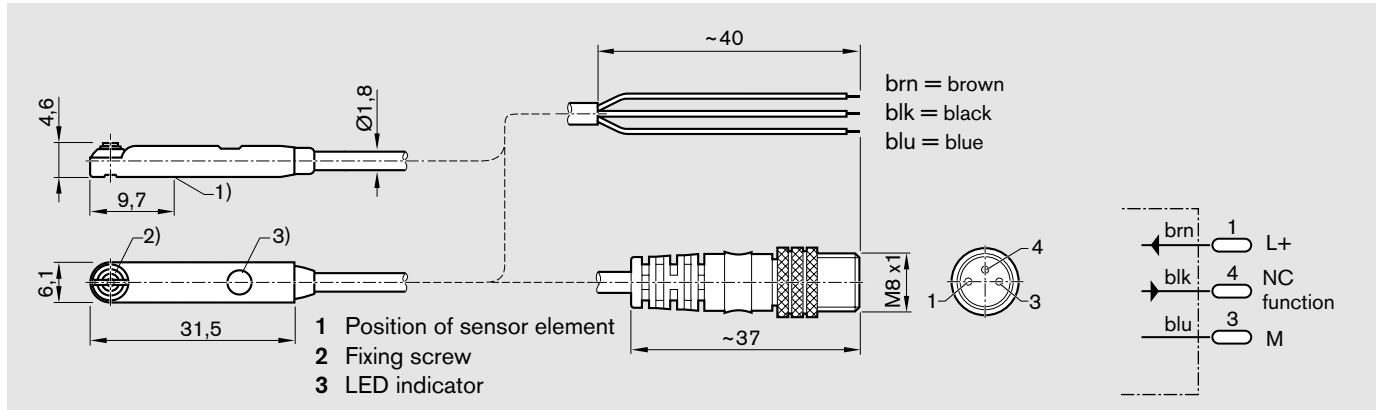

Part number	R3476 027 03	R3476 028 03
Type	Sensor (electronic)	Sensor (elektronic)
Electrical design	DC 3-wire	DC 3-wire
Power supply voltage U_v	DC 10 ... 30 V	DC 10 ... 30 V
Sensitivity	2.6 mT	2.6 mT
Residual ripple U_{pp}	$\leq 10\%$	$\leq 10\%$
Power consumption	$\leq 10 \text{ mA}^{1)}$	$\leq 10 \text{ mA}^{1)}$
Continuous current I_a	$\leq 200 \text{ mA}$	$\leq 200 \text{ mA}$
Hysteresis H typ.	$> 0.5 \text{ mT}$	$> 0.5 \text{ mT}$
Repeatability R	$\leq 0.1 \text{ mT}$ (U_v and T_a constant)	$\leq 0.1 \text{ mT}$ (U_v and T_a constant)
EMC	as per EN 60947-5-2	as per EN 60947-5-2
Switching output	PNP	PNP
Output function	NC function	NC function
Connection type	PVC, 10 m	Cable with M8 connector, 3-pin, knurled screw, PUR, 0.3 m
Enclosure type	IP68, IP69K ²⁾	IP68
Contact type	contactless PNP NC	contactless PNP NC
Switching frequency max.	1.0 kHz	1.0 kHz
Wire break protection	yes	yes
Short-circuit protection	yes ³⁾	yes ³⁾
Polarity safe	yes	yes
Power-up pulse suppression	yes	yes
Shock/vibration stress	30g, 11 ms/10 ... 55 Hz, 1 mm	30g, 11 ms/10 ... 55 Hz, 1 mm
Ambient temperature T_a	- 30 ... 80 °C	- 30 ... 80 °C
Housing material	Plastic	Plastic

- 1) at rest
2) as per DIN 40050, Part 9
3) (clocked)

Extension cable for sensor

The extension cable (approx. 5 m) is supplied complete with a female connector M8x1 for connection to the sensor.

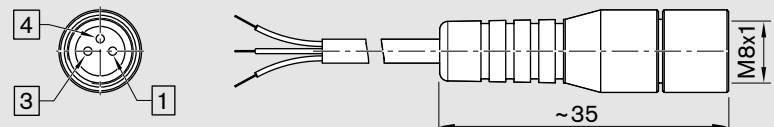

Part number	Connector contact	1	3	4	Protection class
R3476 025 03	to core	brown	blue	black	IP 66 when connected
	Pin assignment	+3.8 ... 30 VDC	0V ground	Output	

Mounting Elements

For EMC with belt side drive and motor

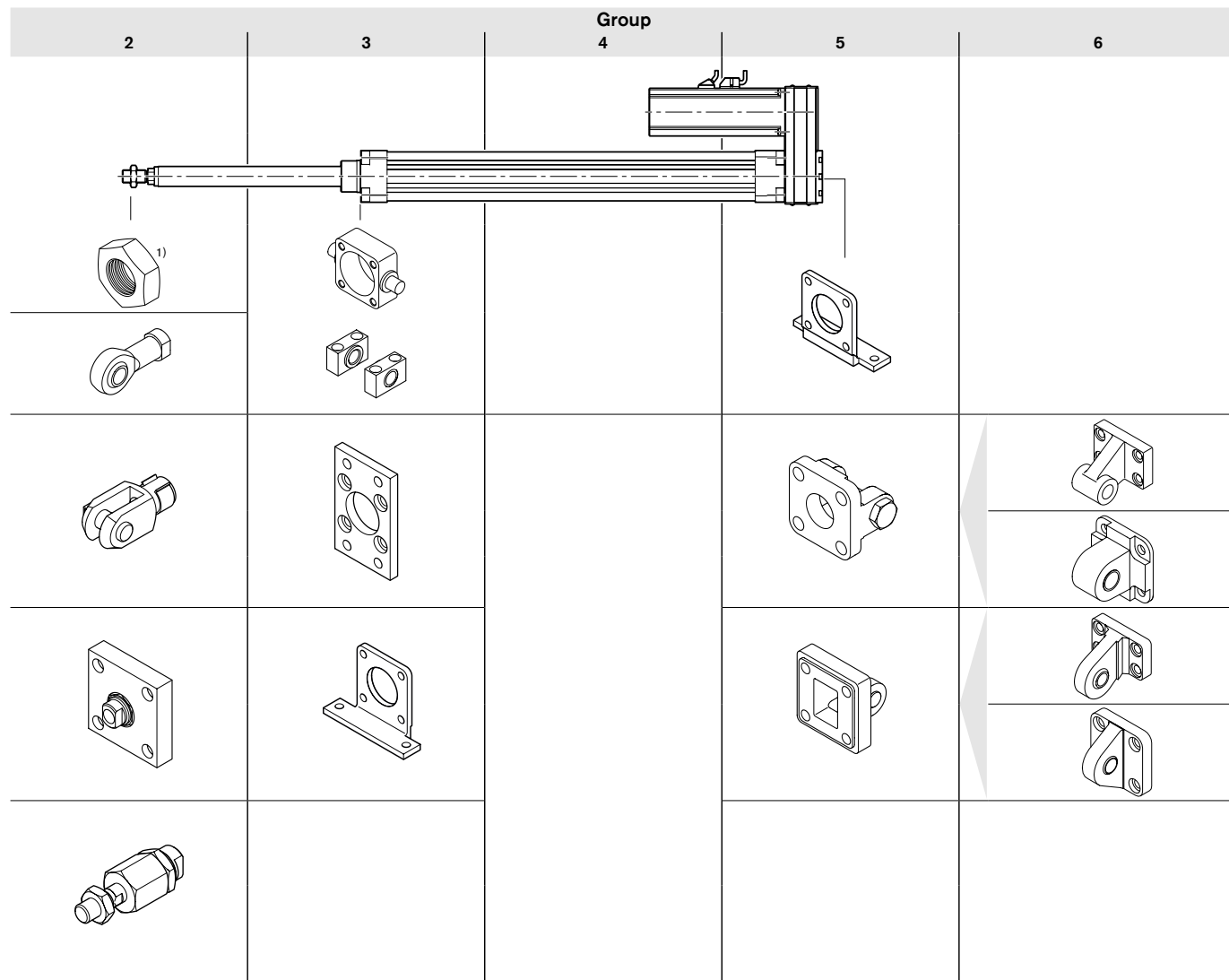

1) Nut is included in the scope of delivery. Can be ordered as an accessory.

Attaching the mounting elements

Mounting elements are attached at the rear end of the belt drive. The screws are included in the delivery of the mounting elements.

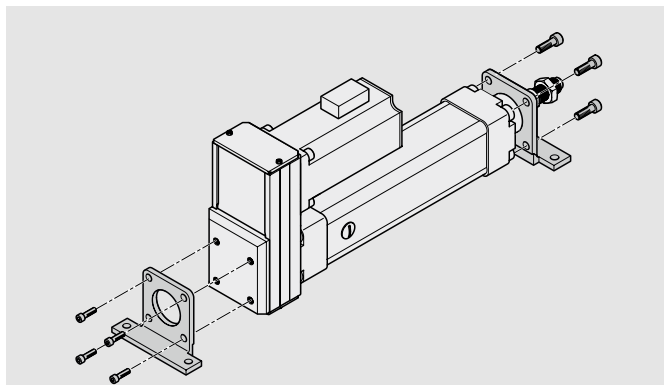

For EMC with motor mount and motor

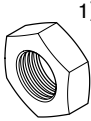
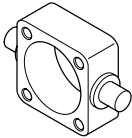
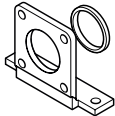
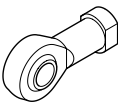
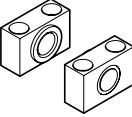
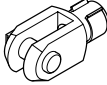
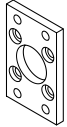
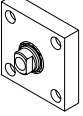
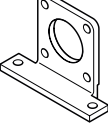
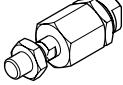
Group				
2	3	4	5	
 <p>1)</p>				
				
				
				
				

1) Nut is included in the scope of delivery. Can be ordered as an accessory.

Mounting Elements

Part numbers – for re-ordering single parts

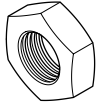
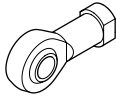
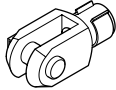
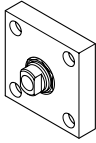
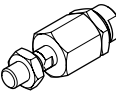
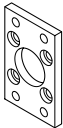
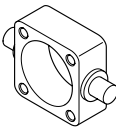
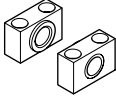
Group	Description	Size	Part number
2	Nut 	32	R021U90014
		40	R021U90015
		50	R021U90016
		63	
		80	R021U90017
		100	
2	Female spherical rod end bearing 	32	R021U90018
		40	R021U90001
		50	R021U90019
		63	
		80	R021U90006
		100	
2	Female clevis 	32	R021U90020
		40	R021U90021
		50	R021U90022
		63	
		80	R021U90023
		100	
2	Flexible coupling with mounting plate 	32	R021U90024
		40	R021U90025
		50	R021U90005
		63	
		80	R021U90026
		100	
2	Flexible coupling 	32	R021U90009
		40	R021U90003
		50	R021U90027
		63	
		80	R021U90008
		100	
3	Flange mount 	32	R021U90035
		40	R021U90007
		50	R021U90036
		63	R021U90037
		80	R1561 5A0 02
		100	R1561 6A0 02
3	Trunnion for rod end cover 	32	R021U90028
		40	R021U90002
		50	R021U90029
		63	R021U90030
		80	R1561 5A0 01
		100	R1561 6A0 01
3	Bearing for trunnion, metal 	32	R021U90031
		40	R021U90032
		50	
		63	R021U90033
		80	
		100	R021U90034

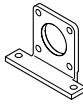
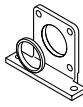
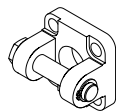
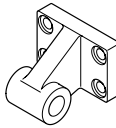
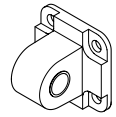
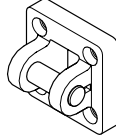
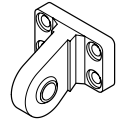
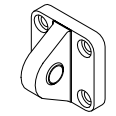
Group	Description	Size	Part number
3, 5	Foot mount For mounting to EMC head and end cap for motor attachment via timing belt side drive (RV01) 	32	R1561 1B1 01
		40	R1561 2B1 01
		50	R1561 3B1 01
		63	R1561 4B1 01
		80	R1561 5B1 01
		100	R1561 6B1 01
5	Foot mount For mounting to EMC end cap for motor attachment via motor mount and coupling (MF01) 	32	R1561 1B1 02
		40	R1561 2B1 02
		50	R1561 3B1 02
		63	R1561 4B1 02
		80	R1561 5B1 02
		100	R1561 6B1 02
5	Clevis mount, Delivery incl. pivot pin 	32	R021U90045
		40	R021U90046
		50	R021U90047
		63	R021U90048
		80	R021U90049
		100	R021U90050
6	Bearing block 	32	R021U90057
		40	R021U90058
		50	R021U90059
		63	R021U90060
		80	R021U90061
		100	R021U90062
6	Swivel mount 	32	R021U90063
		40	R021U90064
		50	R021U90065
		63	R021U90066
		80	R021U90067
		100	R021U90068
5	Clevis mount, for swivel bearing Delivery incl. pivot pin 	32	R021U90069
		40	R021U90070
		50	R021U90071
		63	R021U90072
		80	R021U90073
		100	R021U90074
6	Swivel bearing, high 	32	R021U90075
		40	R021U90076
		50	R021U90077
		63	R021U90078
		80	R021U90079
		100	R021U90080
6	Swivel bearing 	32	R021U90081
		40	R021U90082
		50	R021U90083
		63	R021U90084
		80	R021U90085
		100	R021U90086

Dimensions

Nut

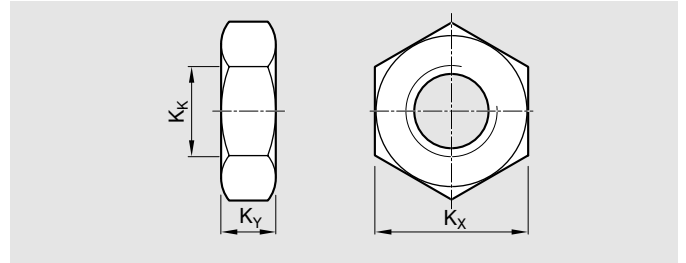

Material: galvanized steel

EMC size	Part number	Order quantity	Dimensions (mm)			Weight (kg)
			K_K	K_X	K_Y	
32	R021U90014	50	M10x1.25	17	6	0.010
40	R021U90015	50	M12x1.25	19	7	0.012
50	R021U90016	25	M16x1.5	24	8	0.017
63						
80	R021U90017	25	M20x1.5	30	10	0.030
100						

(One unit provided in delivery scope of EMC.)

Female spherical rod end bearing

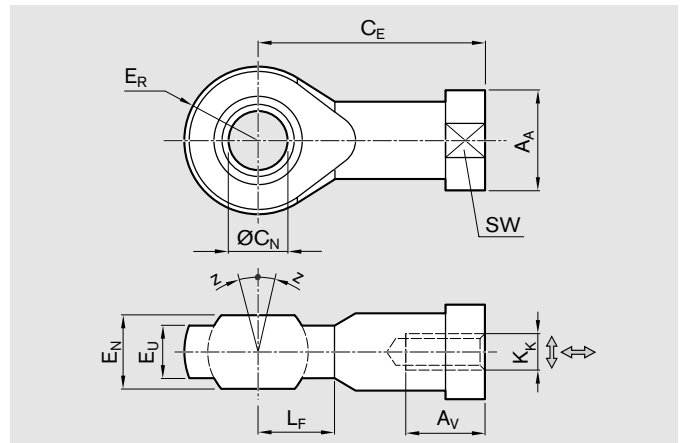

Material: galvanized steel

EMC size	Part number	Dimensions (mm)											Weight (kg)
		A_A	A_V min.	C_E	$\varnothing C_N$ H7	$E_N -0.1$	E_R	E_U max.	K_K	L_F	SW	Z (°)	
32	R021U90018	19	15	43	10	14	14	11.5	M10x1.25	14	17	4	0.070
40	R021U90001	22	18	50	12	16	16	12.5	M12x1.25	16	19	4	0.105
50	R021U90019	27	24	64	16	21	21	15.5	M16x1.5	21	22	4	0.210
63													
80	R021U90006	34	30	77	20	25	25	18.5	M20x1.5	25	30	4	0.380
100													

SW = width across flats

Mounting Elements

Female clevis

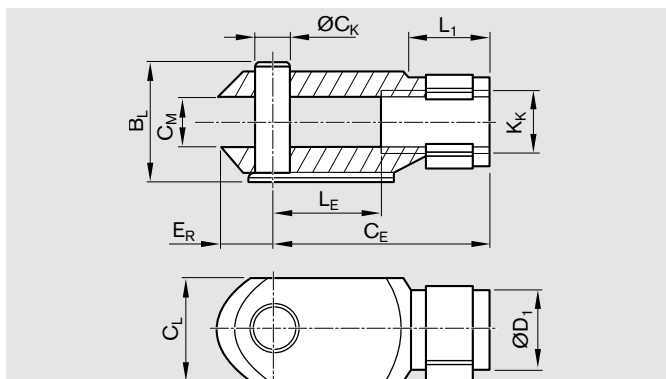

Material: galvanized steel

EMC size	Part number	Dimensions (mm)										Weight (kg)
		B _L	C _E	ØC _K e11	C _L	C _M	ØD ₁	E _R	K _K	L ₁	L _E	
32	R021U90020	26	40	10	20	10	18	12	M10x1.25	15	20	0.100
40	R021U90021	31	48	12	24	12	20	14	M12x1.25	18	24	0.154
50	R021U90022	39	64	16	32	16	26	19	M16x1.5	24	32	0.352
63												
80	R021U90023	50	80	20	40	20	34	20	M20x1.5	30	40	0.700
100												

Flexible coupling with mounting plate

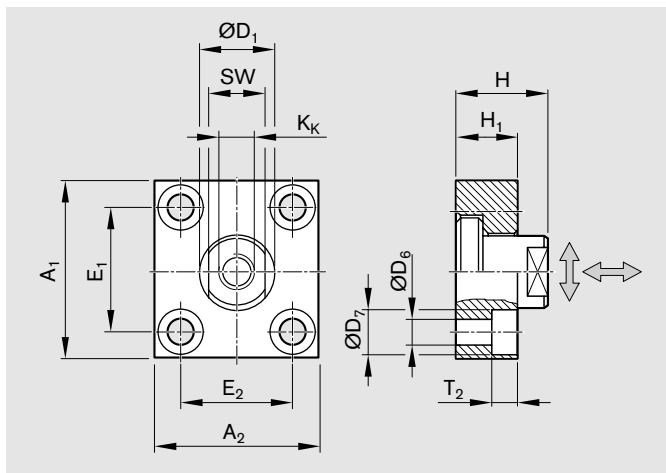

Material: galvanized steel

EMC size	Part number	Dimensions (mm)												Weight (kg)
		A ₁	A ₂	ØD ₁ H11	ØD ₆ H13	ØD ₇ H13	E ₁ H13	E ₂	H ₁	H	K _K	T ₂	SW	
32	R021U90024	60	37	20	6.6	11	36±0.15	23±0.15	15	24	M10x1.25	7	17	0.30
40	R021U90025	60	56	25	9.0	15	42±0.20	38±0.20	20	30	M12x1.25	9	19	0.40
50	R021U90005	80	80	30	11.0	18	58±0.20	58±0.20	20	32	M16x1.5	11	24	0.90
63														
80	R021U90026	90	90	40	14.0	20	65±0.30	65±0.30	20	35	M20x1.5	13	36	1.15
100														

↔ Axial backlash of 0.4 to 0.8 mm

↕ Radial clearance 2 ±0.13 mm

SW = width across flats

Flexible coupling

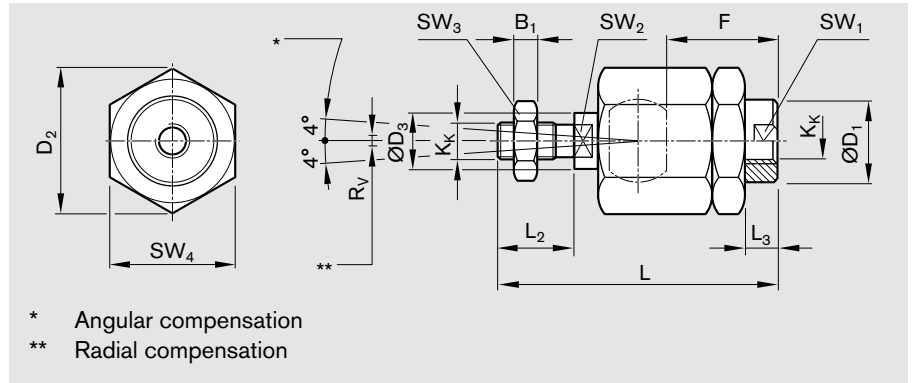

Material: galvanized steel

EMC size	Part number	Dimensions (mm)														Weight (kg)
		B ₁	ØD ₁	D ₂	ØD ₃	F	K _k	L ±2	L ₂	L ₃ ±1	SW ₁	SW ₂	SW ₃	SW ₄	R _v	
32	R021U90009	6	21.5	34	14	23	M10x1.25	73	20	7.5	19	12	17	30	0.7	0.21
40	R021U90003	7	21.5	34	14	28	M12x1.25	77	24	13.0	19	12	19	30	0.7	0.21
50	R021U90027	8	33.5	47	22	32	M16x1.5	108	32	9.0	30	19	24	41	1.0	0.65
63																
80	R021U90008	10	33.5	47	22	42	M20x1.5	122	40	19.0	30	19	30	41	1.0	0.68
100																

SW = width across flats

- For mounting to the piston rod end:
- self-aligning
 - increases mounting tolerances
 - simplifies cylinder mounting

Flange mount

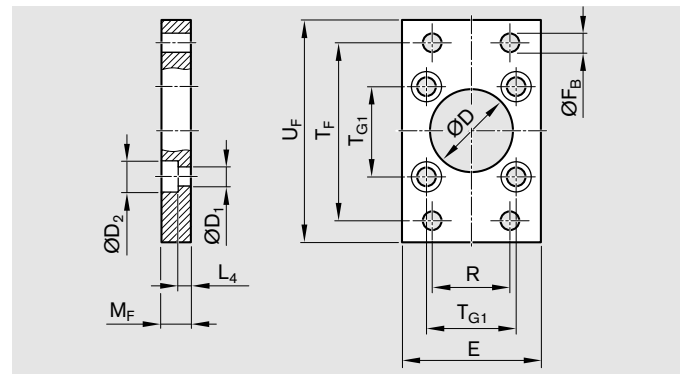

Material: galvanized steel

EMC size	Part number	Dimensions (mm)											Weight (kg)
		ØD H11	ØD ₁ H13	ØD ₂ H13	E max.	ØF _B	L ₄	M _F	R	T _F	T _{G1} ±0.2	U _F	
32	R021U90035	30	6.6	11	50	7	4.5	10	32	64	32.5	80	0.3
40	R021U90007	35	6.6	11	55	9	4.5	10	36	72	38.0	90	0.4
50	R021U90036	40	9.0	15	65	9	6.0	12	45	90	46.5	110	0.8
63	R021U90037	45	9.0	15	75	9	6.0	12	50	100	56.5	125	1.0
80	R1561 5A0 02	55	11.0	18	100	12	9.0	16	63	126	72.0	154	1.7
100	R1561 6A0 02	65	11.0	18	120	14	9.0	16	75	150	89.0	186	2.4

Fastening screws included in scope of delivery

Mounting Elements

Trunnion for head end (For vertical EMC orientations only)

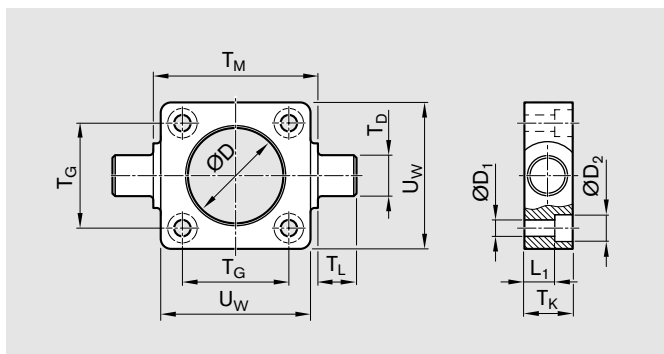

Material: galvanized spheroidal graphite cast iron

EMC size	Part number	Dimensions (mm)										Weight (kg)
		ØD H11	ØD ₁	ØD ₂	L ₁	T _D e9	T _G ±0.2	T _K	T _L h14	T _M h14	U _W	
32	R021U90028	30	6.6	11	7.5	12	32.5	16	12	50	48	0.29
40	R021U90002	35	6.6	11	7.5	16	38.0	20	16	63	56	0.50
50	R021U90029	40	9.0	15	10.0	16	46.5	24	16	75	65	0.70
63	R021U90030	45	9.0	15	10.0	20	56.5	24	20	90	75	1.10
80	R1561 5A0 01	55	11.0	18	16.0	20	72.0	28	20	110	100	1.50
100	R1561 6A0 01	65	11.0	18	25.5	25	89.0	38	25	132	120	2.70

Fastening screws included in scope of delivery

Bearing for trunnion, metal

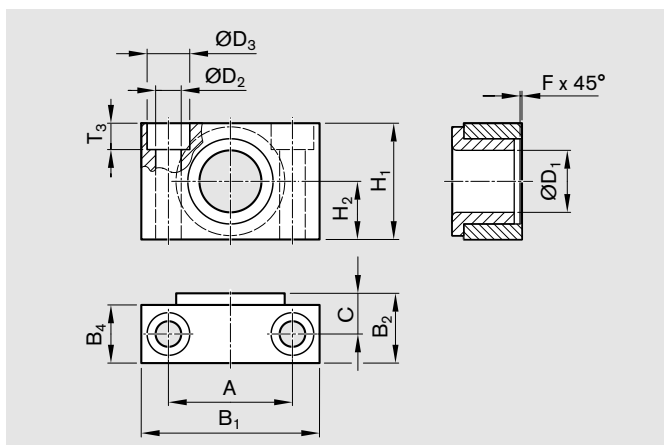

Material: galvanized steel, with sintered bronze bushings, delivered in pairs

EMC size	Part number	Dimensions (mm)											
		A ±0.2	B ₁ f8	B ₂	B ₄	C	ØD ₁ H7	ØD ₂ H12	ØD ₃ H13	F x 45°	H ₁	H ₂ ±0.1	T ₃ -0.4
32	R021U90031	32	46	18.0	15	10.5	12	6.6	11	1.0	30	15	6.8
40	R021U90032	36	55	21.0	18	12.0	16	9.0	15	1.6	36	18	9.0
50	R021U90033	42	65	23.0	20	13.0	20	11.0	18	1.6	40	20	11.0
63													
80	R021U90034	50	75	28.5	25	16.0	25	14.0	20	2.0	50	25	13.0
100													

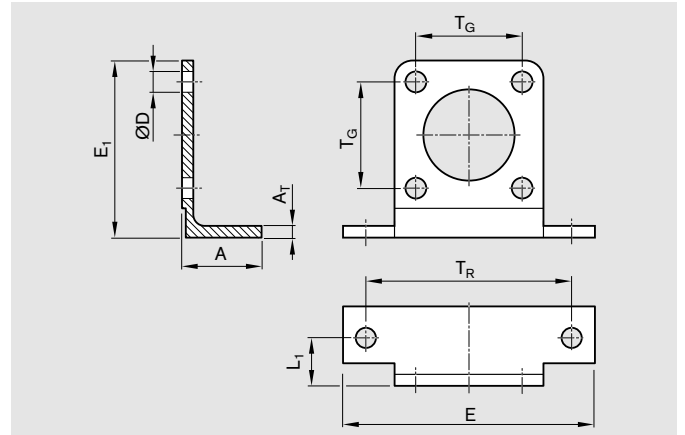
Foot mount, for attachment to head cap or timing belt side drive

Material: galvanized steel

For mounting to EMC head and end cap for motor attachment via timing belt side drive (RV01)

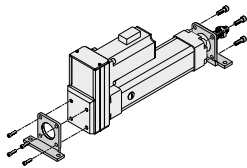

EMC size	Part number	Dimensions (mm)									Weight (kg)
		A ±0.2	A _T ±0.2	ØD H13	E	E ₁	L ₁ ±0.2	T _G ±0.2	T _R ±0.2		
32	R1561 1B101	30	6	6.6	79	55.5	18	32.5	65	0.15	
40	R1561 2B101	30	7	6.6	90	62.5	18	38.0	75	0.16	
50	R1561 3B101	35	7	9.0	110	77.5	21	46.5	90	0.26	
63	R1561 4B101	35	7	9.0	120	87.5	21	56.5	100	0.32	
80	R1561 5B101	40	10	11.0	153	110.5	27	72.0	128	0.76	
100	R1561 6B101	40	10	11.0	178	128.5	27	89.0	148	1.10	

Fastening screws included in scope of delivery

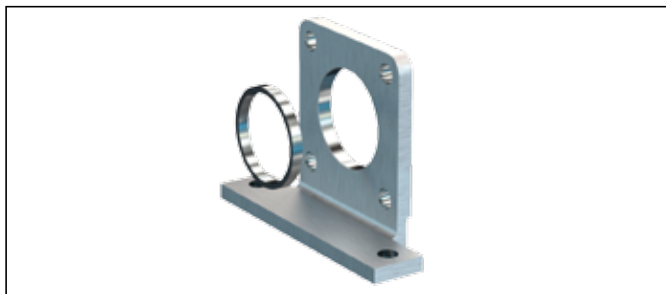
Foot mount with centering ring for attachment to end cap, between EMC and motor mount

For dimensions, see drawing at top

Material: galvanized steel

For mounting to EMC end cap for motor attachment via motor mount and coupling (MF01)

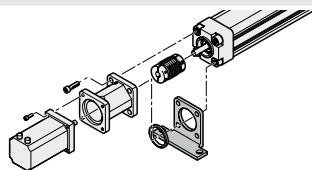

EMC size	Part number	Dimensions (mm)									Weight ¹⁾ (kg)
		A ±0.2	A _T ±0.2	ØD H13	E	E ₁	L ₁ ±0.2	T _G ±0.2	T _R ±0.2		
32	R1561 1B102	30	6	6.6	79	55.5	18	32.5	65	0.156	
40	R1561 2B102	30	7	6.6	90	62.5	18	38.0	75	0.166	
50	R1561 3B102	35	7	9.0	110	77.5	21	46.5	90	0.267	
63	R1561 4B102	35	7	9.0	120	87.5	21	56.5	100	0.329	
80	R1561 5B102	40	10	11.0	153	110.5	27	72.0	128	0.787	
100	R1561 6B102	40	10	11.0	178	128.5	27	89.0	148	1.130	

1) Including weight of the ring

Fastening screws included in scope of delivery

Mounting Elements

Clevis mount

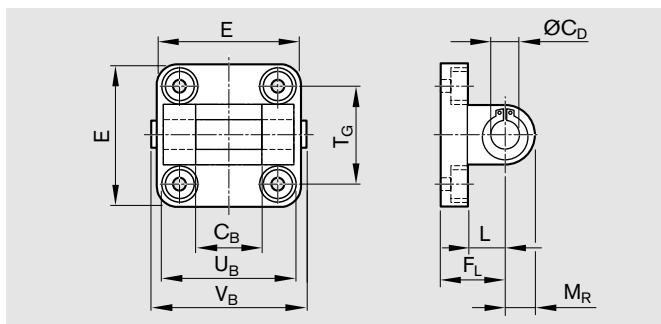

Material: anodized die-cast aluminum

EMC size	Part number	Dimensions (mm)										Weight (kg)
		C _B H14	ØC _D H9	E max.	F _L ±0.2	L min.	M _R	T _G ±0.2	U _B h14	V _B		
32	R021U90045	26	10	47	22	12	11	32.5	45	50	0.09	
40	R021U90046	28	12	54	25	15	13	38.0	52	57	0.11	
50	R021U90047	32	12	65	27	15	13	46.5	60	65	0.18	
63	R021U90048	40	16	75	32	20	17	56.5	70	76	0.25	
80	R021U90049	50	16	94	36	20	17	72.0	90	96	0.51	
100	R021U90050	60	20	112	41	25	21	89.0	110	117	0.70	

Pivot pin and fastening screws included in scope of delivery

Swivel mount (mating piece for clevis mount, p. 40)

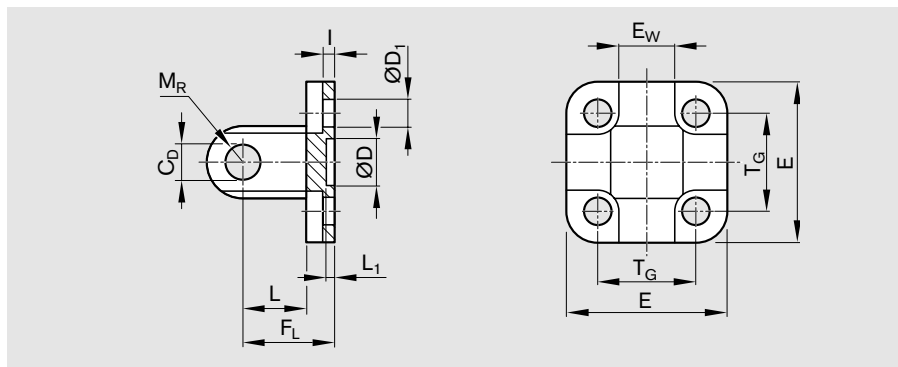

Material: aluminum

EMC size	Part number	Dimensions (mm)											
		C _D H9	ØD H11	D ₁ H13	E	E _w -0.2/-0.6	F _L ±0.2	I ±0.5	L min.	L ₁ min.	M _R max.	T _G ±0.2	DIN 912
32	R021U90063	10	30	6.6	48	26	22	5.5	12	4.5	10	32.5	M6x18
40	R021U90064	12	35	6.6	53	28	25	5.5	15	4.5	12	38.0	M6x18
50	R021U90065	12	40	9.0	63	32	27	6.5	15	4.5	12	46.5	M8x20
63	R021U90066	16	45	9.0	73	40	32	6.5	20	4.5	16	56.5	M8x20
80	R021U90067	16	45	11.0	98	50	36	10.0	20	4.5	16	72.0	M10x20
100	R021U90068	20	55	11.0	115	60	41	10.0	25	4.5	20	89.0	M10x20

Fastening screws included in scope of delivery

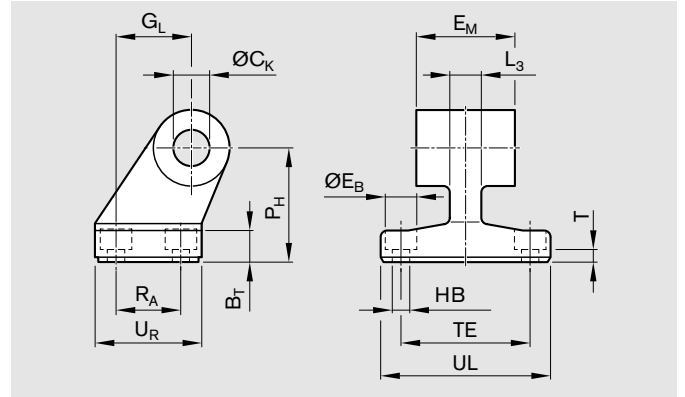
Bearing block (mating piece for clevis mount, p. 40)

Material: galvanized spheroidal graphite cast iron

EMC size	Part number	Dimensions (mm)														Weight (kg)
		BR	BT	ØCK H9	ØEB H13	EM -0.2/-0.6	GL	ØHB H13	L3	PH JS15	RA JS14	T	TE JS14	UL	UR	
32	R021U90057	10	8	10	10	26	21	5.5	10	32	18	4	38	51	31	0.166
40	R021U90058	11	10	12	10	28	24	5.5	10	36	22	4	41	54	35	0.222
50	R021U90059	13	12	12	11	32	33	6.6	14	45	30	6	50	65	45	0.433
63	R021U90060	15	12	16	11	40	37	6.6	14	50	35	6	52	67	50	0.550
80	R021U90061	15	14	16	15	50	47	9.0	18	63	40	6	66	86	60	0.956
100	R021U90062	18	15	20	15	60	55	9.0	20	71	50	6	76	96	70	1.488

Without fastening screws

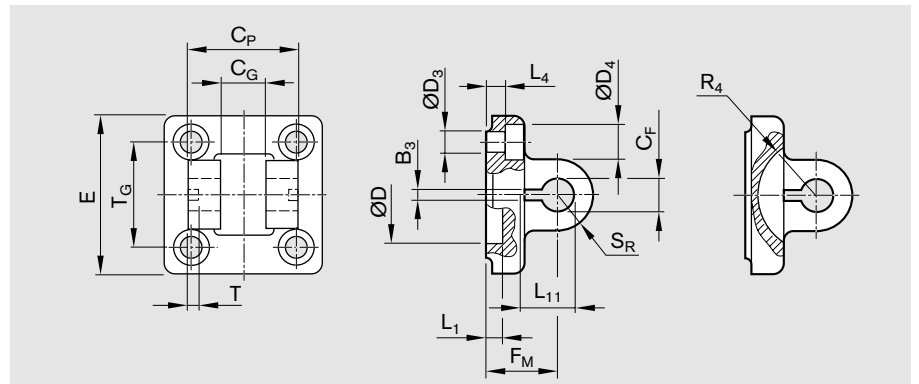
Clevis mount, for swivel bearing

Material: aluminum

EMC size	Part number	Dimensions (mm)																Weight (kg)	
		B3 ±0.2	CF F7	CG D10	CP d12	Ød3	Ød4	ØD	E	FM ±0.2	L1 ±0.5	L4 ±0.5	L11 -0.5	R4	SR	T ±0.2	TG ±0.2		DIN 912
32	R021U90069	3.3	10	14	34	6.6	11	30	49	22	4.5	5.5	16.5	17	11	3	32.5	M6x18	0.216
40	R021U90070	4.3	12	16	40	6.6	11	35	55	25	4.5	5.5	18.0	20	12	4	38.0	M6x18	0.286
50	R021U90071	4.3	16	21	45	9.0	15	40	67	27	4.5	6.5	23.0	22	15	4	46.5	M8x20	0.487
63	R021U90072	4.3	16	21	51	9.0	15	45	77	32	4.5	6.5	23.0	25	15	4	56.5	M8x20	0.676
80	R021U90073	4.3	20	25	65	11.0	18	45	97	36	4.5	10.0	27.0	30	20	4	72.0	M10x20	1.385
100	R021U90074	4.3	20	25	75	11.0	18	55	117	41	4.5	10.0	27.0	32	20	4	89.0	M10x20	2.036

Pivot pin and fastening screws included in scope of delivery

Mounting Elements

Swivel bearing (mating piece for clevis mount, p. 41)

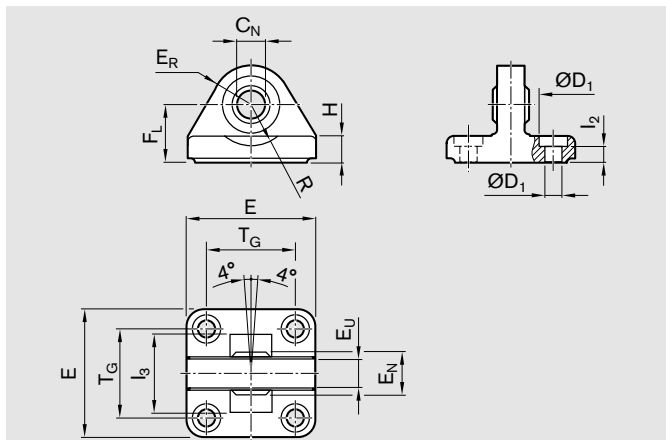
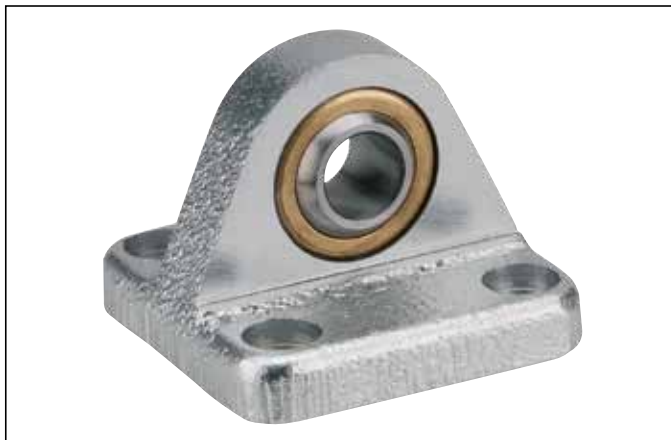

Material: aluminum

EMC size	Part number	Dimensions (mm)												DIN 912	Weight (kg)
		ØC _N H7	ØD ₁ H13	E	E _N -0.1	E _R	E _U	F _L -0.2	H	l ₂	l ₃ min.	R	T _G ±0.2		
32	R021U90081	10	6.6	47	14	15	9.0	22	9.0	5.5	36	15	32.5	M6x18	0.214
40	R021U90082	12	6.6	53	16	18	9.0	25	9.0	5.5	42	16	38.0	M6x18	0.283
50	R021U90083	16	9.0	65	21	20	10.5	27	10.5	6.5	48	16	46.5	M8x20	0.428
63	R021U90084	16	9.0	75	21	23	15.0	32	10.5	6.5	55	18	56.5	M8x20	0.684
80	R021U90085	20	11.0	95	25	27	18.0	36	14.0	10.0	70	21	72.0	M10x20	1.212
100	R021U90086	20	11.0	115	25	30	18.0	41	15.0	10.0	80	21	89.0	M10x20	2.032

Fastening screws included in scope of delivery

Swivel bearing high (mating piece for clevis mount, p. 41)

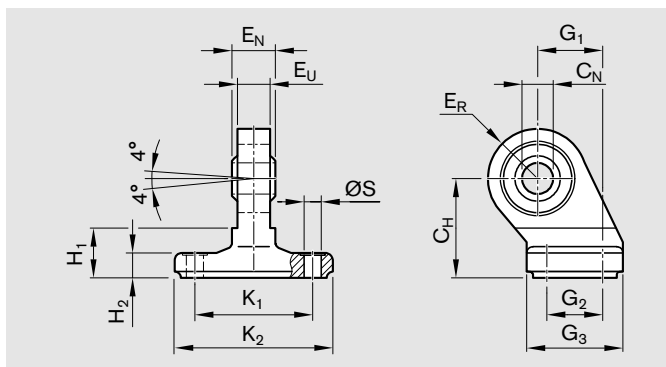

Material: galvanized spheroidal graphite cast iron

EMC size	Part number	Dimensions (mm)												ØS
		C _H JS15	C _N H7	E _N -1.0	E _R max.	E _U	G ₁ JS14	G ₂ JS14	G ₃ max.	H ₁	H ₂	K ₁ JS14	K ₂ max.	
32	R021U90075	32	10	14	16	10.5	21	18	31	16	9 ^{±1.0}	38	51	6.6
40	R021U90076	36	12	16	18	12.0	24	22	35	16	9 ^{±1.0}	41	54	6.6
50	R021U90077	45	16	21	21	15.0	33	30	45	23	11 ^{±1.0}	50	65	9.0
63	R021U90078	50	16	21	23	15.0	37	35	50	23	11 ^{±1.0}	52	67	9.0
80	R021U90079	63	20	25	28	18.0	47	40	60	32	12 ^{±1.5}	66	86	11.0
100	R021U90080	71	20	25	30	18.0	55	50	70	33	13 ^{±1.5}	76	96	11.0

Without fastening screws

Guide unit GH1 with plain bearing

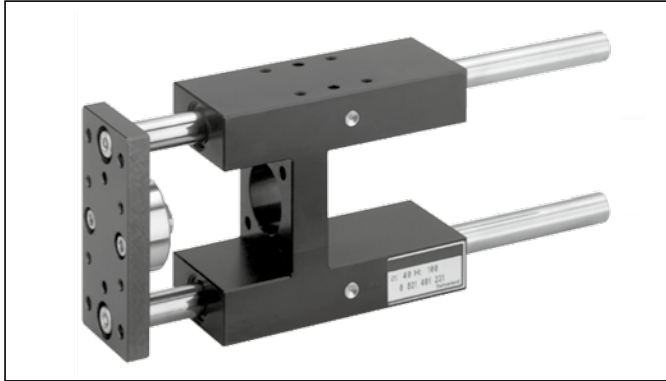

Guide unit GH2 with linear ball bearing

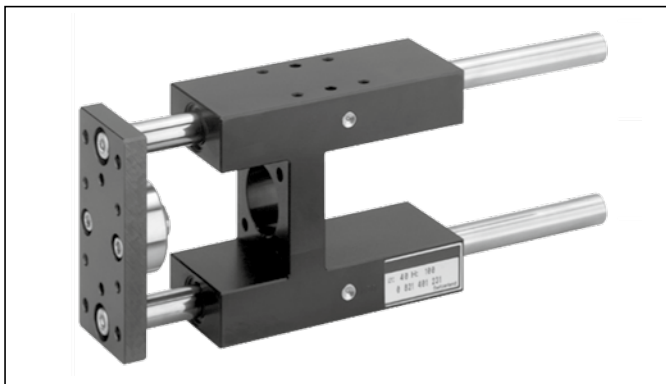

Note: If required, guide units can be used for EMC sizes 32 to 63.
For more information, please refer to www.boschrexroth.com/dcp

Lubrication

Grease lubrication

Standard lubrication practices for ball bearings also apply to the ball screws used in the EMC.

The advantage of grease lubrication is that the ball screw can run long distances on one supply of grease. As a result, a lubricating system is not required in many cases.

All commercially available high-quality ball bearing lubricating greases may be used. Read the lubricant manufacturer's specifications carefully! Never use greases with solid lubricant components (e.g. graphite or MoS₂).

Greases in accordance with DIN 51825-K2K and, for higher loads, KP2K of NLGI Class 2 in accordance with DIN 51818 are recommended for the longest possible lubrication intervals. Tests have shown that greases of NLGI Class 00 achieve only about 50% of the running performance of Class 2 at higher loads.

The relubrication interval depends on many factors such as the degree of contamination, operating temperature, load, etc. The following values can thus serve only as a guide.

Lubrication notes

Basic lubrication is applied in-factory before shipment.

The EMC is designed for grease lubrication (using a manual grease gun with extension tube and nozzle).

The only maintenance required is lubrication of the ball screw assembly via the lube port.

For lubrication, retract the piston to the position S.

For more information, see "Mounting Instructions for EMC," R320103103

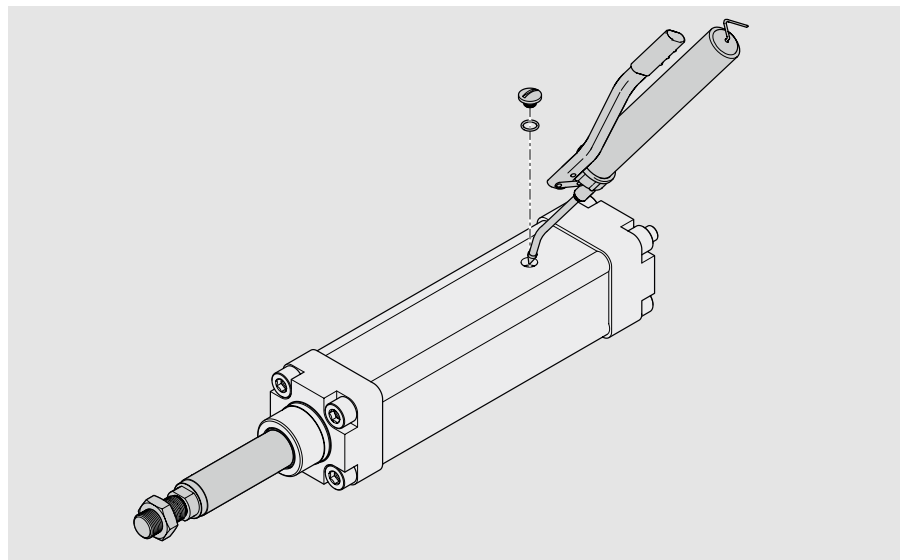

Relubrication intervals for NLGI-2 greases

Limit conditions:

Load = $\leq 0.2 C$

n_{min} = 100 min⁻¹

Orientation: any

Operating mode: no short strokes
($s_{max} < 100$ mm)

Sealing: standard

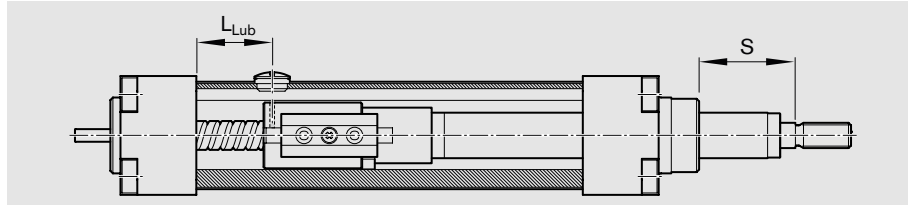

EMC size	Ball screw lead P (mm)	Revolutions U (mill.)	Stroke (km)	Grease relubricating quantity (g)	L_{Lub} (mm)	S (mm)
32	5	50	250	0.30	25	30.0
	10		500	0.30		29.0
40	5	50	250	0.60	25	27.8
	10		500	0.80		27.5
	16		800	1.10		27.5
50	5	50	250	1.00	30	34.5
	10		500	1.40		34.5
	20		1000	2.20		34.5
63	5	50	250	1.40	30	34.5
	10		500	1.70		34.5
	25		1250	3.10		33.5
80	5	50	250	2.00	40	44.0
	10		500	2.80		46.5
	20		1000	3.20		46.5
	32		1600	4.90		46.5
100	5	50	250	2.70	40	39.5
	10		500	7.30		42.0
	20		1000	7.80		42.0
	40		2000	12.90		42.0

Recommended lubricants

 Do not use greases containing solid particles (e.g. graphite or MoS2)!

EMC size	Grease DIN 51825	Consistency class DIN 51818
32 - 100	KP2K	NLGI 2

Motors

Overview

 The motor is selected after determining the main application data (geometry, drive type, required thrust, speed, and stroke).

Type

MSK



The **MSK** range of **servo motors** has a wide power spectrum and narrow size increments. The high torque density of these synchronous servo motors allows a particularly compact design with high torques.

Specification:

- Smooth shaft with shaft seal ring
- Multi-turn absolute encoder (Hiperface), $128 \cdot 2^{13}$ increments with 4096 revolutions. With this encoder type, the absolute axis position is saved even after the power is switched off.
- Cooling system: Natural convection
- Protection class IP65
- With or without holding brake

Product advantages:

- High operational reliability
- Compact construction
- High-performance and dynamic
- High torque density
- High protection rating IP65
- Maximum precision through optical encoder

MSM



The maintenance-free **servo motors MSM** expand the digital drive technology portfolio in the lower power range. Offering high power density in a compact design with minimized flange dimensions, this range of motors is ideal for machine concepts for high dynamic processes.

Specification:

- Smooth shaft
- Multi-turn absolute encoder (Hiperface)
- Cooling system: Natural convection
- Protection class IP54
- With or without holding brake

Product advantages:

- High operational reliability
- Maintenance-free operation (through brushless design and the use of long-lasting grease-lubricated bearings)
- High performance data
- High dynamics (through favorable torque-inertia mass ratio)
- Simple cable management and quick start-up

AC servo motors MSK

Dimensions

**SAFETY
ON
BOARD**

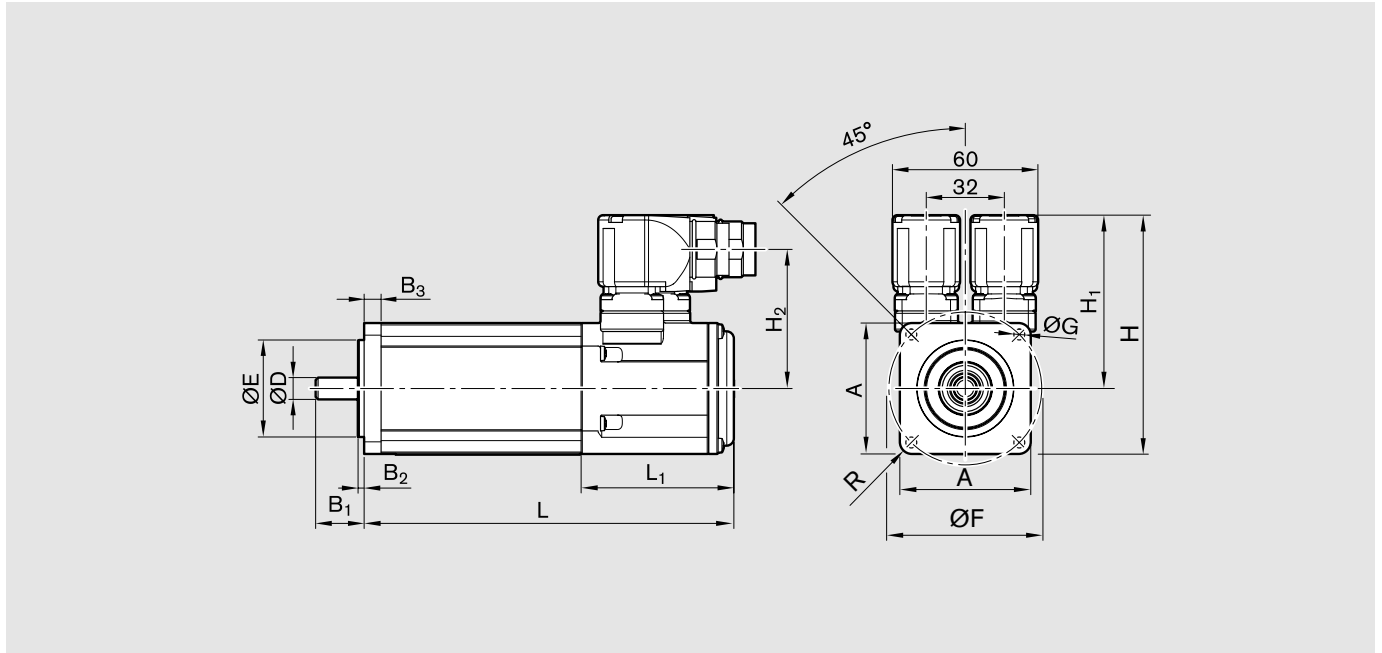

Motor type	Dimensions (mm)														
	A	B ₁	B ₂	B ₃	ØD k6	ØE j6	ØF	ØG	H	H ₁	H ₂	w/o brake	L with brake	L ₁	R
MSK 030C	54	20	2.5	7.0	9	40	63	4.5	98.5	71.5	57.4	188.0	213.0	-	R5
MSK 040C	82	30	2.5	8.0	14	50	95	6.6	124.5	83.5	69.0	185.5	215.5	42.5	R8
MSK 050C	98	40	3.0	9.0	19	95	115	9.0	134.5	85.5	71.0	203.0	233.0	55.5	R8
MSK 060C	116	50	3.0	9.5	24	95	130	9.0	156.5	98.5	84.0	226.0	259.0	48.0	R9
MSK 076C	140	50	4.0	14.0	24	110	165	11.0	180.0	110.0	95.6	292.5	292.5	79.0	R12

Motor data independent of EMC

Description	Symbol	Unit	MSK030C-0900	MSK040C-0600	MSK050C-0600	MSK060C-0600	MSK076C-0450
Maximum useful speed	n_{\max}	(min^{-1})	9000	6000	6000	6000	4500
Maximum torque	M_{\max}	(Nm)	4	8.1	15	24	43.5
Rated torque	M_N	(Nm)	0.8	2.7	5.0	8.0	12.0
Rotor mass moment of inertia without brake	J_{Rot}	(10^{-6}kgm^2)	30	140	330	800	4300
Mass of motor without brake	m_M	(kg)	1.9	3.6	5.4	8.4	13.8
Holding brake							
Holding torque	M_{Br}	(Nm)	1.0	4.0	5.0	10.0	11.0
Brake mass moment of inertia	J_{Br}	(10^{-6}kgm^2)	7	23	107	59	360
Mass of brake	m_{Br}	(kg)	0.2	0.3	0.9	0.8	1.1

Notes

The motors can be delivered complete with controllers. Please refer to the catalogs "IndraDrive Cs for Linear Motion Systems" and "IndraDrive C for Linear Motion Systems" for more information about motors and control systems.

Motors

AC servo motors MSM

Dimensions

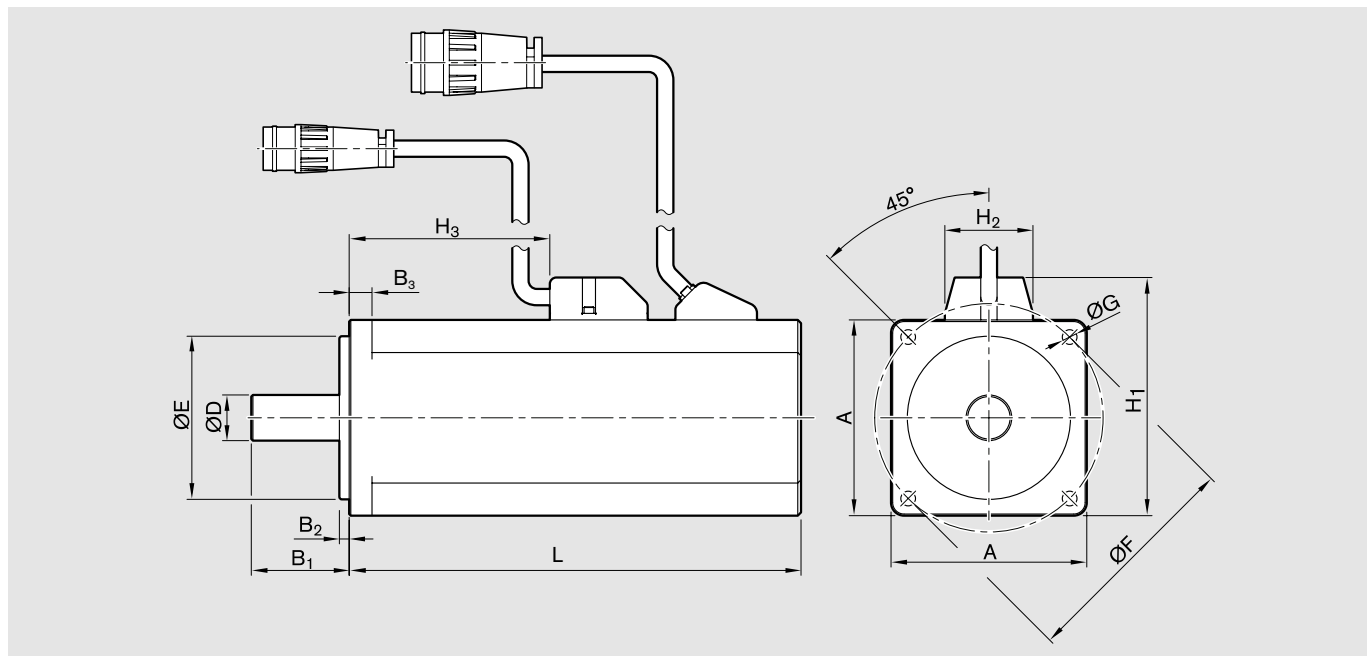

Motor type	Dimensions (mm)												
	A	B ₁	B ₂	B ₃	$\varnothing D$ h6	$\varnothing E$ h7	$\varnothing F$	$\varnothing G$	H ₁	H ₂	H ₃	w/o brake	with brake
MSM 019B	38	25	3	6.0	8	30	45	3.4	51	27	40.8	92.0	122.0
MSM 031B	60	30	3	6.5	11	50	70	4.5	73	36	22.5	79.0	115.5
MSM 031C	60	30	3	6.5	14	50	70	4.5	73	36	42.0	98.5	135.0
MSM 041B	80	35	3	6.0	19	70	90	6.0	93	36	52.5	112.0	149.0

Motor data independent of EMC

Description	Symbol	Unit	MSM 019B	MSM 031B	MSM 031C	MSM 041B
Maximum useful speed	n_{\max}	(min^{-1})	5000	5000	5000	4500
Maximum torque	M_{\max}	(Nm)	0.95	1.91	3.80	7.10
Rated torque	M_N	(Nm)	0.32	0.64	1.30	2.40
Rotor mass moment of inertia w/o brake	J_{Rot}	(10^{-6}kgm^2)	5.1	14.0	26.0	87.0
Mass of motor without brake	m_M	(kg)	0.47	0.82	1.20	2.30
Holding brake						
Holding torque	M_{Br}	(Nm)	0.29	1.27	1.27	2.45
Brake mass moment of inertia	J_{Br}	(10^{-6}kgm^2)	0.2	1.8	1.8	7.5
Mass of brake	m_{Br}	(kg)	0.21	0.48	0.50	0.80

Notes

The motors can be delivered complete with controllers. Please refer to the catalogs "IndraDrive Cs for Linear Motion Systems" and "IndraDrive C for Linear Motion Systems" for more information about motors and control systems.

Notes

Configuration and Ordering

The EMC is available in fixed lengths or freely configurable lengths. For freely configurable EMC versions, please specify the order code.

Size Part number	Mechanical cylinder system					
	Screw lead (mm)	Max. travel (mm)	Seal system	Preload of ball nut	Tolerance grade	Ball nut
EMC32 R156010000	5 [01]	...	Standard [1]	Reduced backlash [1]	T7	Standard [01]
	10 [02]	...		2% preload [3]		
EMC40 R156020000	5 [01]	...	Standard [1]	Reduced backlash [1]	T7	Standard [01]
	10 [02]	...		2% preload [3]		
	16 [03]	...				
EMC50 R156030000	5 [01]	...	Standard [1]	Reduced backlash [1]	T7	Standard [01]
	10 [02]	...		2% preload [3]		
	20 [04]	...				

EMC fixed lengths

EMCs with fixed lengths have faster delivery times than EMCs with freely configurable lengths.

Note:

The faster delivery times apply only to the fixed-length EMC without attachments.

Fixed-length EMCs are as defined in the table. In addition, they have



- a standard seal
- reduced backlash
- tolerance grade T7.

For fixed lengths with fixed strokes, please select the part number from the table.

EMC size	Ball screw		Part number for max. travel (mm)			
	d ₀ (mm)	Lead P (mm)	100	200	320	400
32	12	5	R1560 111 00	R1560 112 00	–	–
		10	R1560 121 00	R1560 122 00	–	–
40	16	5	R1560 211 00	R1560 212 00	R1560 213 20	R1560 214 00
		10	R1560 221 00	R1560 222 00	R1560 223 20	R1560 224 00
		16	–	R1560 232 00	–	–
50	20	5	R1560 311 00	R1560 312 00	–	R1560 314 00
		20	–	R1560 342 00	–	–

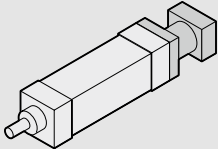
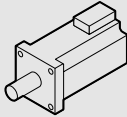

Consider excess travel.

Version	Motor attachment	Motor		Documentation		
						
Fig. 1, Fig. 2	Gear ratio i	Attachment kit ¹⁾	for motor	without brake	with brake	
OF01		00		00		
MF01		05	MSK 030C	84	85	
		13	MSM 019B	104	105	
		14	MSM 031B	106	107	
RV01 RV02 RV03	i = 1	33	MSM 019B	104	105	
		34	MSM 031B	106	107	
		35	MSK 030C	84	85	
OF01		00		00		
MF01		05	MSK 030C	84	85	
		13	MSM 019B	104	105	
		14	MSM 031B	106	107	
RV01 RV02 RV03	i = 1	36	MSM 031C	108	109	
		37	MSK 030C	84	85	
		38	MSK 040C	86	87	
	i = 1.5	39	MSM 031C	108	109	
		40	MSK 030C	84	85	
		41	MSK 040C	86	87	
OF01		00		00		
MF01		05	MSK 030C	84	85	
		06	MSK 040C	86	87	
		15	MSM 031C	108	109	
RV01 RV02 RV03	i = 1	42	MSM 031C	108	109	
		43	MSM 041B	110	111	
		44	MSK 040C	86	87	
	i = 1.5	45	MSK 050C	88	89	
		46	MSM 031C	108	109	
		47	MSM 041B	110	111	
48	MSK 040C	86	87			

Standard ²⁾ 01

1) Attachment kit also available without motor (when ordering: enter "00" for motor).

2) The standard report serves to confirm that the checks listed in the report have been carried out and that the measured values lie within the permissible tolerances.

Version

Motor mount

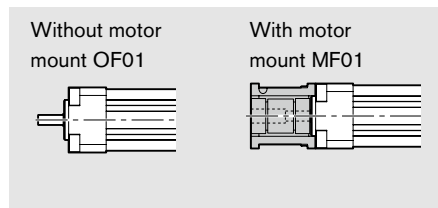

Fig. 1

Timing belt side drive

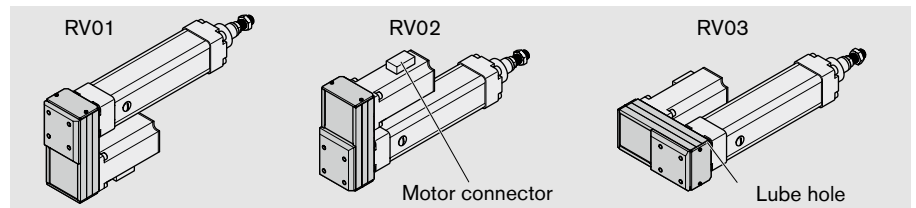

Fig. 2

For explanations of the ordering parameters, see "Inquiry / Order Form"

Configuration and Ordering

The EMC is available in fixed lengths or freely configurable lengths. For freely configurable EMC versions, please specify the order code.

Size Part number	Mechanical cylinder system					
	Screw lead (mm)	Max. travel (mm)	Seal system	Preload of ball nut	Tolerance grade	Ball nut
EMC63 R156040000	5 [01]	...	Standard [1]	Reduced backlash [1]	T7	Standard [01]
	10 [02]			2% preload [3]		
	25 [05]					
EMC80 R156050000	5 [01]	...	Standard [1]	Reduced backlash [1]	T7	Standard [01]
	10 [02]					
	20 [04]			2% preload [3]		
	32 [06]					
EMC100 R156060000	5 [01]	...	Standard [1]	Reduced backlash [1]	T7	Standard [01]
	10 [02]					
	20 [04]			2% preload [3]		
	40 [07]					

EMC fixed lengths

EMCs with fixed lengths have faster delivery times than EMCs with freely configurable lengths.

Note:

The faster delivery times apply only to the fixed-length EMC without attachments.

Fixed-length EMCs are as defined in the table. In addition, they have



- a standard seal
- reduced backlash
- tolerance grade T7.

For fixed lengths with fixed strokes, please select the part number from the table.

EMC size	Ball screw		Part number for max. travel (mm)			
	d ₀ (mm)	Lead P (mm)	100	200	320	400
63	25	5	R1560 411 00	R1560 412 00	–	R1560 414 00
		10	–	R1560 422 00	–	R1560 424 00
80	32	5	R1560 511 00	R1560 512 00	–	–
		10	–	R1560 522 00	–	R1560 524 00
100	40	5	–	R1560 612 00	–	–
		20	–	–	–	R1560 644 00

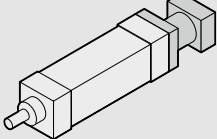

Consider excess travel

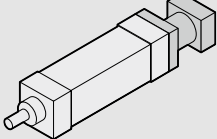
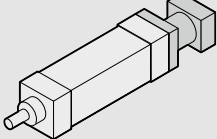
Version	Motor attachment		Motor		Documentation		
	Fig. 1, Fig. 2	Gear ratio i	Attachment kit ¹⁾	for motor without brake with brake			
	OF01		00	00	 Standard ²⁾ 01		
	MF01		06	MSK 040C		86	87
			07	MSK 050C		88	89
			16	MSM 041B		110	111
	RV01 RV02 RV03	i = 1	49	MSM 041B		110	111
			50	MSK 040C		86	87
			51	MSK 050C		88	89
		i = 2	52	MSK 060C		90	91
			53	MSM 041B		110	111
			54	MSK 040C		86	87
55	MSK 050C	88	89				
	OF01		00	00	Standard ²⁾ 01		
	MF01		06	MSK 040C		86	87
			07	MSK 050C		88	89
			08	MSK 060C		90	91
			09	MSK 076C		92	93
	RV01 RV02 RV03	i = 1	56	MSK 050C		88	89
			57	MSK 060C		90	91
			58	MSK 076C		92	93
		i = 2	59	MSK 050C		88	89
			60	MSK 060C		90	91
	OF01		00	00	Standard ²⁾ 01		
	MF01		08	MSK 060C		90	91
			09	MSK 076C		92	93
	RV01 RV02 RV03	i = 1	61	MSK 060C		90	91
			62	MSK 076C		92	93
		i = 2	63	MSK 060C		90	91
64			MSK 076C	92	93		

1) Attachment kit also available without motor (when ordering: enter "00" for motor).

2) The standard report serves to confirm that the checks listed in the report have been carried out and that the measured values lie within the permissible tolerances.

Version

Motor mount

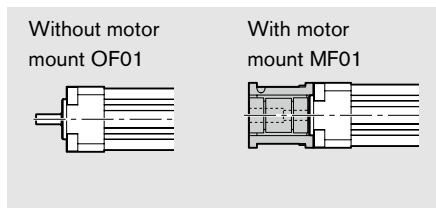

Fig. 1

Timing belt side drive

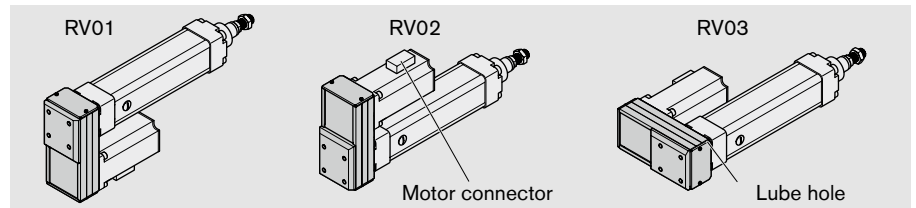





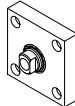

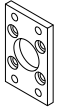

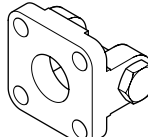



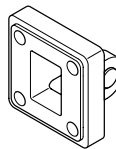



Fig. 2

For explanations of the ordering parameters, see "Inquiry / Order Form"

Configuration and Ordering









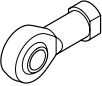

Mounting elements for version RV01 to RV03 (with belt side drive)

	Group					
	1	2	3	4	5	6
Without mounting element	[00]	[00]	[00]	[00]	[00]	[00]
		 1) [01]				
		 [02]	 [01]			
		 [03]	 [03]			
		 [04]	 [04]			
		 [05]	 [06]			
		 [06]			 [06]	
					 [07]	 [01]
						 [02]
						 [03]
					 [08]	 [04]

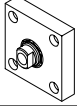
1) Nut is included in the scope of delivery.

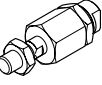
Can be ordered separately as an accessory by specifying option [05].

 If no mounting elements are required, option [00] must be selected for each group.

Mounting elements for version MF01 (with flange)	Group				
	1	2	3	4	5
Without mounting element	[00]	[00]	[00]	[00]	[00]
					
		[01]	[01]		
					
		[02]	[03]		
					
		[03]			
					
		[04]	[04]		
					
		[05]	[06]		
					
					[09]
					

1) Nut is included in the scope of delivery.

Can be ordered separately as an accessory by specifying option [05].

 If no mounting elements are required, option [00] must be selected for each group.

All mounting elements are supplied as loose parts along with the delivery. The foot mount for MF01, option [09], is delivered ready-mounted. Foot mounts are mounted so that the T-slot for switches and the lube hole are accessible from the side of the unit.

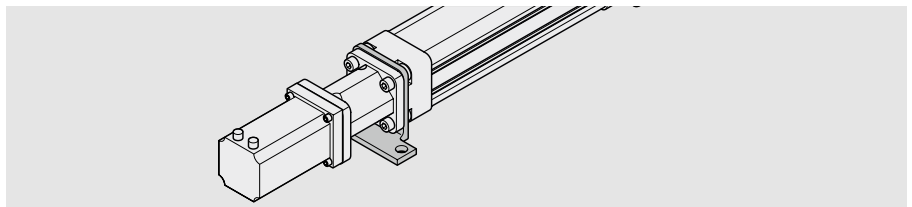

Inquiry / Order Form

Bosch Rexroth Corporation

Linear Motion and
 Assembly Technologies
 14001 South Lakes Drive
 Charlotte, NC 28273

Telephone (800) 438-5983
 Facsimile (704) 583-0523
 www.boschrexroth-us.com

For explanations of the ordering parameters, see pages 50-53, "Configuration and Ordering."

Ordering example: EMC80			
Ordering data		Description	
Size	= EMC80		
Screw lead	= 01	Screw lead 5 mm	
Max. travel	= 200	Max. travel 200 mm	
Seal system	= 1	Standard	
Preload	= 1	Reduced backlash	
Tolerance grade	= T7	Tolerance grade T7	
Ball nut	= 01	Standard	
Version	= RV02	With belt side drive for motor attachment	
Motor attachment	= 56	Attachment kit: Belt side drive for motor MSK 050C, i = 1	
Motor	= 89	Motor MSK 050C with brake	
Documentation	= 01	Standard documentation	
Mounting elements	Group 1	= 00	None
	Group 2	= 01	Female spherical rod end bearing
	Group 3	= 04	Head/cap end flange mount
	Group 4	= 00	None
	Group 5	= 06	Foot mount
	Group 6	= 00	None

To be completed by customer: Inquiry / Order

Electromechanical Cylinder EMC

Size	= _____	
Screw lead	= _____	
Max. travel	= _____	
Seal system	= 1	
Preload	= _____	
Tolerance grade	= T7	
Ball nut	= 01	
Version	= _____	
Motor attachment	= _____	
Motor	= _____	
Documentation	= 01	
Mounting elements	Group 1	= _____
	Group 2	= _____
	Group 3	= _____
	Group 4	= _____
	Group 5	= _____
	Group 6	= _____

Quantity Order of: _____ pcs, _____ per month, _____ per year, per order, or _____

Comments:

From		
Company:	_____	Name: _____
Address:	_____	Department: _____
	_____	Telephone: _____
	_____	Telefax: _____
		e-mail: _____

Technical Inquiry Sheet for Electromechanical Cylinders

Customer: _____
 Tel.: _____
 e-mail: _____

Description of application: _____

Operating conditions (cycle)

Loads (dynamic) (N)	Travel speeds (m/s)	Discrete time steps (s)
F ₁ =	at v ₁ =	for t ₁ =
F ₂ =	at v ₂ =	for t ₂ =
F ₃ =	at v ₃ =	for t ₃ =
F ₄ =	at v ₄ =	for t ₄ =
F ₅ =	at v ₅ =	for t ₅ =
F ₆ =	at v ₆ =	for t ₆ =

(Please also state the time for any pauses.)

Maximum static load on bearing (if known): _____ N

Required service life: _____ operating hours

EMC duty cycle: _____ % or _____ cycles per minute/hour/day

Effective stroke (useful stroke): _____ mm

EMC mounting orientation: Horizontal Vertical

Installation scenarios:

Case 1

Fixed mounting to head and end cap
(flange or foot mounting).

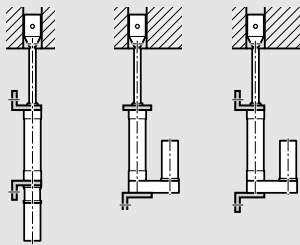

Case 2

Fixed mounting to head cap or end cap
(flange or foot mounting).

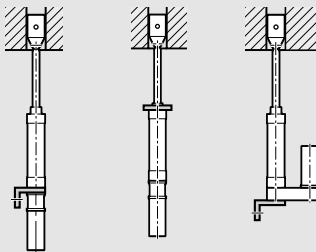

Case 3

All types of articulated mounting.
Pivotable or swivel mountings.

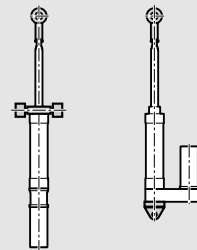

Motor attachment via Motor mount/coupling Timing belt side drive

Other information (e.g. exceptional operating conditions):

Notes

Bosch Rexroth Corporation

Linear Motion and
Assembly Technologies
14001 South Lakes Drive
Charlotte, NC 28273
Telephone (800) 438-5983
Facsimile (704) 583-0523
www.boschrexroth-us.com

Find your local contact person here:
www.boschrexroth-us.com/addresses

The data specified above only serve to describe the product. No statements concerning a certain condition or suitability for a certain application can be derived from our information. The information given does not release the user from the obligation of own judgment and verification. It must be remembered that our products are subject to a natural process of wear and aging.