

Switch mounting arrangements

Overview of switching systems

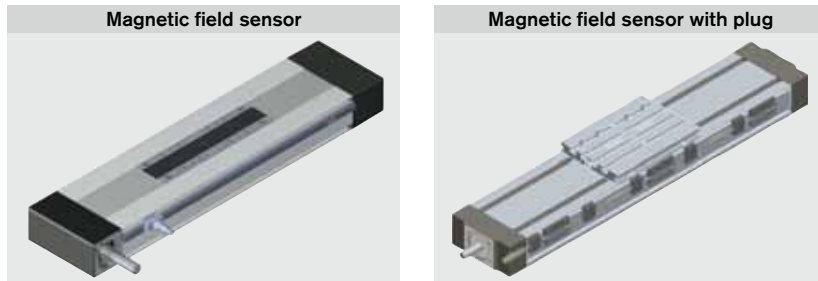

The following switch categories can be used with the Compact Module:
 – Magnetic field sensor (Hall and Reed sensors)
 The entire switching system must be mounted on one side of the Compact Module!

Magnetic field sensor

Hall and Reed sensor

- 1 Socket and plug
- 2 Switch
- 3 Mounting duct (aluminum alloy, black anodized)

⚠ The magnetic field sensors are suitable for travel speeds up to 2 m/s. Short stroke: Take the length of the switch and socket into consideration!

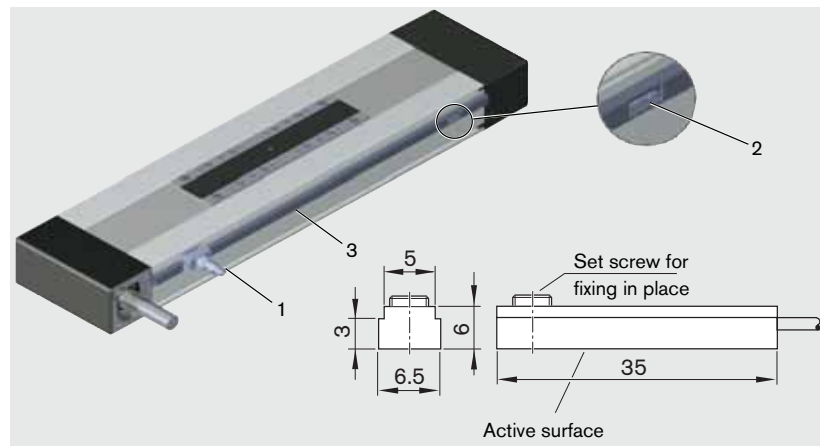

Magnetic field sensors with potted cable.
 Version:

- Hall sensor (normally closed) or
- Reed sensor (change-over)

Mounting instructions:

Switches may be mounted only on one side of the Compact Module (left or right) and only after installing the Compact Module to the mounting base. A mounting duct is needed to fasten the switches.

| Hall sensor | |
|--------------------------|-------------------------|
| Contact type | PNP - NC / NO |
| Operating voltage | 3.8–30 V DC |
| Power consumption | max. 10 mA |
| Output current | max. 20 mA |
| Cable length | 2 m (10 m upon request) |
| Housing protection class | IP 66 |
| Short-circuit protection | No |
| Maximum travel speed | 2 m/s |

| Reed sensor | |
|--------------------------|-------------------------|
| Contact type | Change-over |
| Switching voltage | max. 100 V DC |
| Switching current | max. 0.5 mA |
| Cable length | 2 m (10 m upon request) |
| Housing protection class | IP 66 |
| Maximum travel speed | 2 m/s |

Important: 2 switching points!

Pin assignment

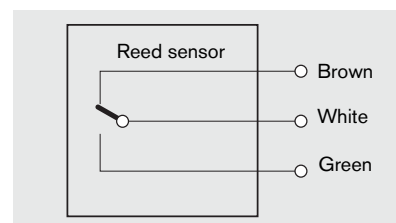
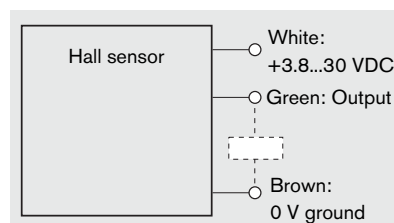

Mounting duct

Function:

- To attach and secure magnetic field sensors
- Cable routing

Mounting instructions:

The mounting duct is hooked into the T-slots of the module frame and secured with set screws.

Set screws are included.

The switches are slid into the T-slot of the mounting duct and secured with set screws.

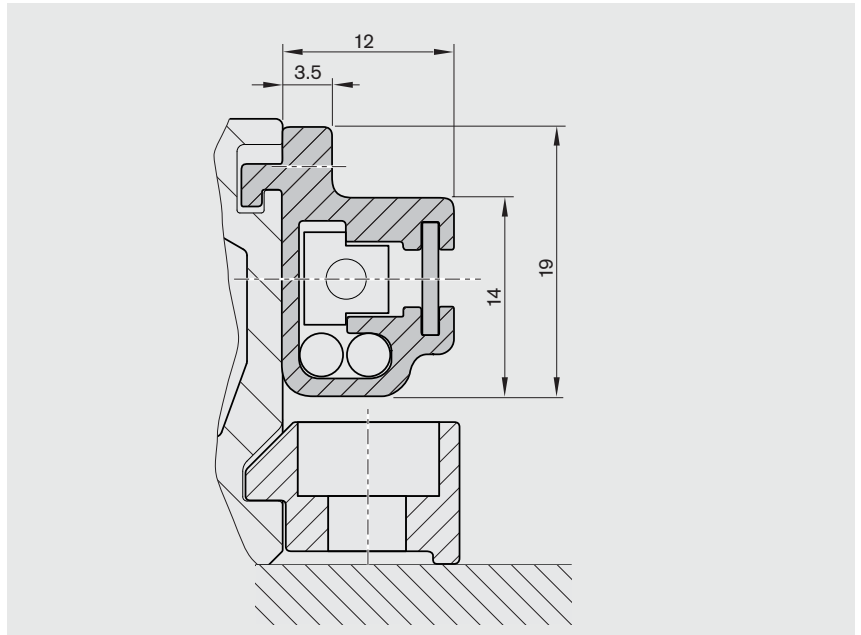

Socket and plug

Attach the socket on the side with the magnetic field sensor.

The socket and plug have 16 pins.

Socket and plug are not wired.

This allows optimal assignment of switch positions during start-up.

One plug is included.

The plug can be installed in three directions.

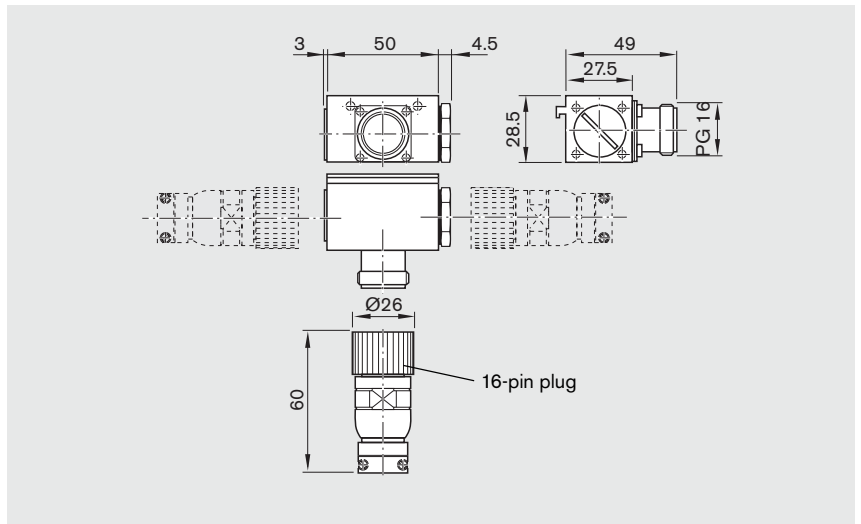

Part numbers of the magnetic field sensors and accessories

| Item | | Part numbers |
|------|--------------------------|--------------|
| 1 | Socket-plug | R0375 400 00 |
| 2 | Magnetic field sensor | |
| | - Reed sensor | R987 146 948 |
| | - Hall sensor (PNP - NC) | R987 146 123 |
| 3 | Mounting duct | R0399 801 20 |

Switch mounting arrangements

Magnetic field sensor with plug

With magnetic field sensors, switch activation is direct (without switching cam). The switch positions can be adjusted freely over the entire travel range. Sensors may be mounted only on one side of the Compact Module (left or right) and only after installing the Compact Module to the mounting base.

Switch positions:

- 1 Limitation at end of stroke (recommendation: Reed or Hall sensor)
- 2 Reference point in middle of stroke (recommendation: Hall sensor)

Sensor mounting assembly

consists of:

- 3 Sensor (Hall or Reed)
- 4 Sensor mount incl. set screws (loose) and square nut **4a**
- 5 Cable holder (3 units) incl. set screw (loose)

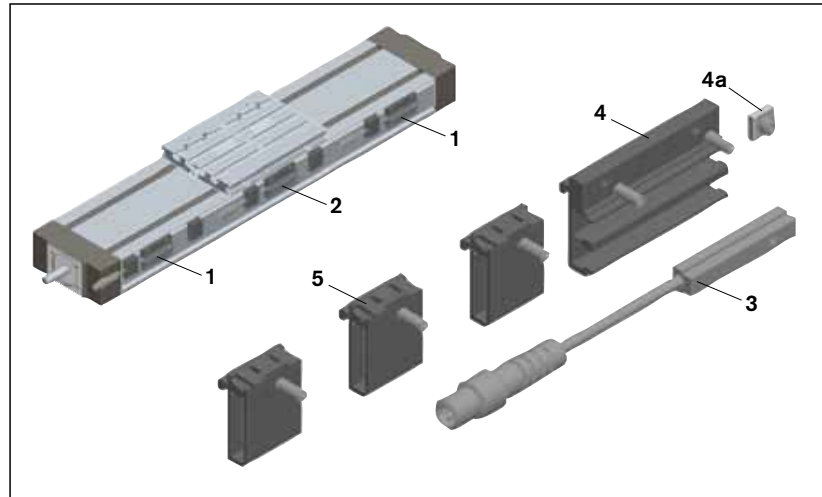

| Version | Part number |
|---|--------------|
| Sensor mounting assembly with Reed sensor | R0375 300 07 |
| Sensor mounting assembly with Hall sensor | R0375 300 08 |

Sensor configuration:

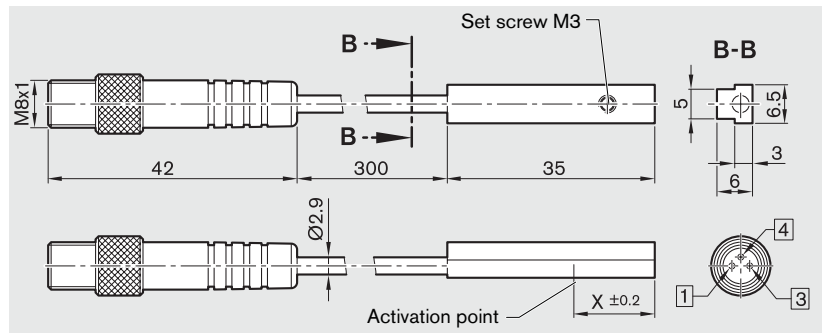

Sensor mount

A sensor mount (1) is required to attach the sensors. It is hooked into the upper slot on the Compact Module and secured with set screws (2). The sensors are pushed into the upper slot of the sensor mount and fixed with a set screw. The square nut with set screw (3) serves as a positive stop for the sensor (switch position when changing sensors). Parts are included with the sensor mounting assembly.

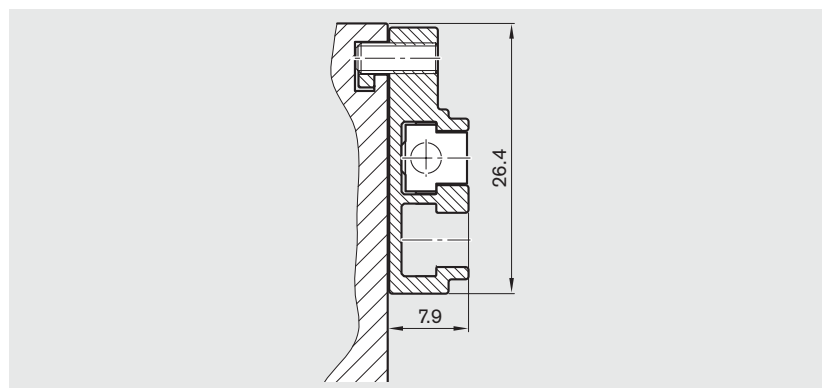

Technical data and ordering

| Part number | Hall sensor R3476 024 03 |
|--------------------------|-----------------------------|
| Dimension X | 13.65 mm |
| Contact type | PNP - NC |
| Operating voltage | 3.8 to 30 V DC |
| Power consumption | max. 10 mA |
| Output current | max. 20 mA |
| Housing protection class | IP 66 |
| Short-circuit protection | No |
| Permissible travel speed | 2 m/s |
| Housing material | Ultramid |

| Part number | Reed sensor R3476 023 03 |
|-------------------------------|-----------------------------|
| Dimension X | 9 mm |
| Contact type | Change-over |
| Switching voltage | max. 100 V DC |
| Switching current | max. 500 mA |
| Housing protection class | IP 66 |
| Permissible travel speed | 2 m/s |
| Housing material | Ultramid |
| Important: 2 switching points | |

Pin assignment

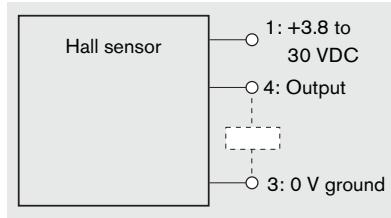

- Hall sensor (PNP - NC contact)

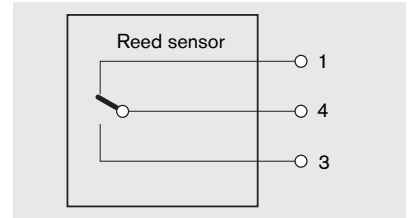

- Reed sensor (change-over)

Extension cable for sensor (Reed/Hall)

The extension cable (approx. 5 m) is supplied complete with a female connector M8x1 for connection to the sensor.

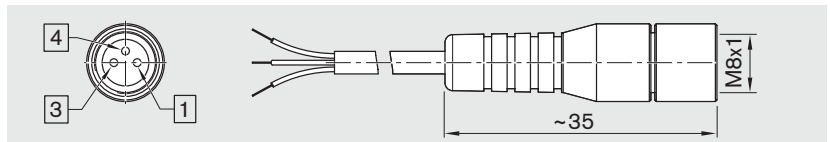

| Extension cable | | | | | |
|-----------------|-------------------|-------|------|-------|----------------------|
| Part number | Connector contact | 1 | 3 | 4 | Protection class |
| R3476 025 03 | to core | brown | blue | black | IP 66 when connected |