

High Precision Ball Runner Blocks made of steel

## Product Description

### Highlights versus existing precision range

- Travel accuracy again further improved by a factor of up to six
- Significantly reduced frictional drag variations and low frictional drag, especially under an applied external load
- Highest precision
- Superior quality
- Extremely low impact on surrounding environment due to minimal oil preservation
- Patented entry zone design enhances travel accuracy
- Plus all further advantages of Rexroth Precision Ball Runner Blocks

### High precision through innovation:

- New entry zone geometry for ball runner blocks:  
The load-dependent entry zone (1) from Rexroth.

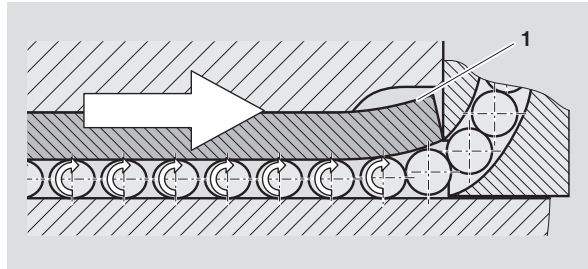

### Application example

Further application examples  83

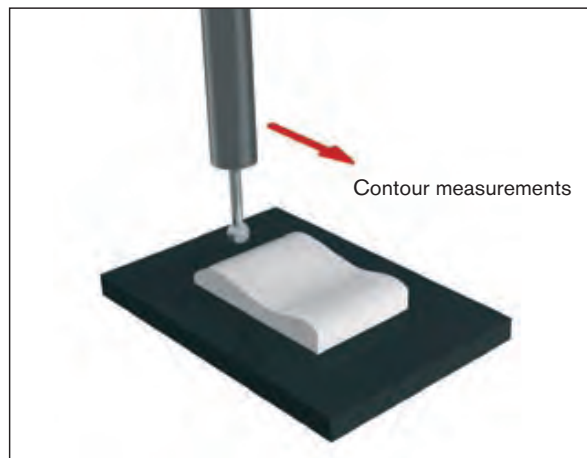

3D coordinate measuring machine

Overview of High Precision Steel Ball Runner Block models

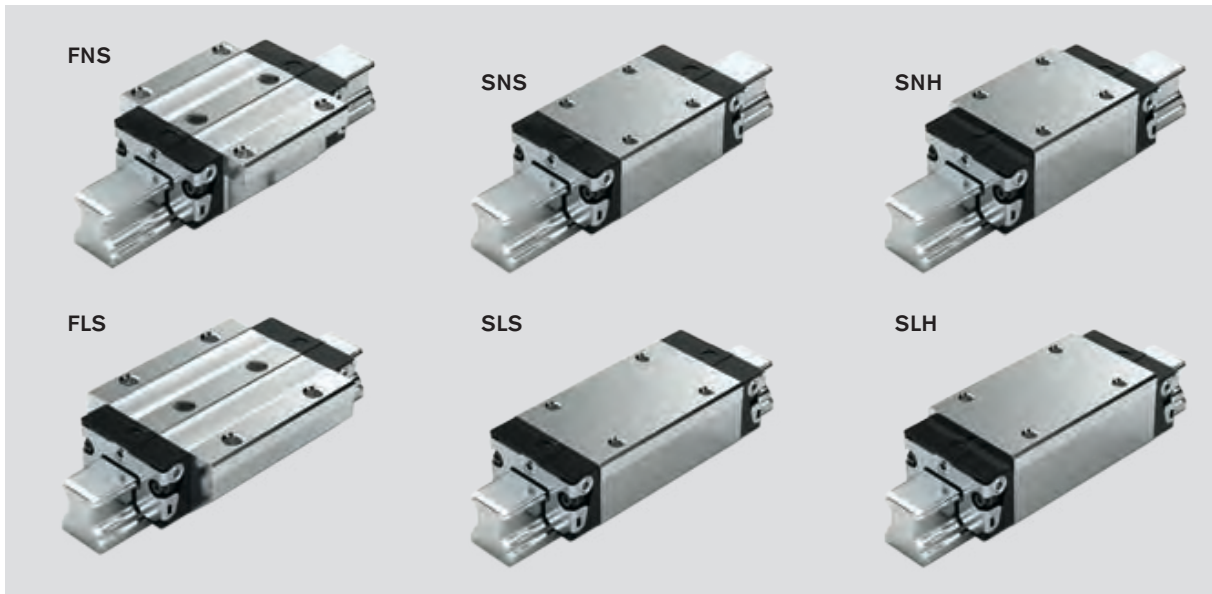

**Ball chain (optional)**  
 - Optimizes noise levels

Definition Ball Runner Block design style		Code (example)		
		F	N	S
Width	Flanged	F		
	Slimline			
	Wide Compact			
Length	Normal		N	
	Long			
	Short			
Height	Standard height			S
	High			
	Low			

High Precision Ball Runner Blocks made of steel

## Comparison

### Conventional Ball Runner Blocks

#### Entry zone geometry for conventional ball runner blocks

If the ball runner block has a conventional entry zone, this can only be designed for a specific load point.

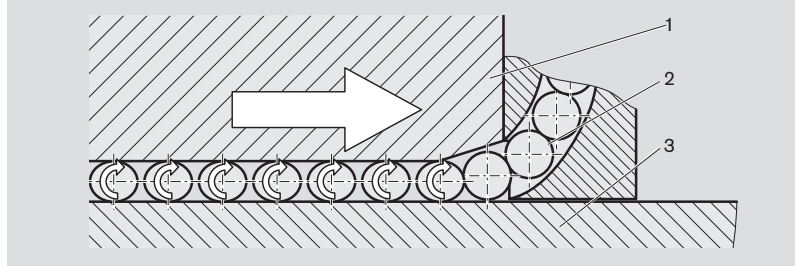

- 1 Ball runner block
- 2 Ball
- 3 Ball guide rail

#### Ball entry

- The balls are guided to the beginning of the entry zone by the ball recirculation track.
- When the distance between the ball runner block (1) and the ball guide rail (3) becomes smaller than the ball diameter, the ball (2) is subjected to loading (preload) in a series of pulses.
- The preload increases in the entry zone and reaches a maximum in the load-bearing zone. The ball transmits the force from the runner block to the rail.
- The kinematic and geometric conditions cause spaces to develop between the balls.

#### Entry zone

Conventional runner blocks have a fixed entry zone. The depth of the entry zone must be designed to withstand high loading, since smooth ball entry must be assured even under very high loads.

- On the one hand, there should be as many load-bearing balls as possible at any one time in the runner block to ensure optimal load capacity of the linear bearing.
  - ➡ shortest possible entry zone
- On the other hand, the increase in loading of the balls upon entry should be as slow and smooth as possible, in order to maximize the geometrical travel accuracy.
  - ➡ shallowest (longest) possible entry zone

These are conflicting aims (short versus long entry zone).

## High Precision Ball Runner Blocks

### New entry zone geometry for high precision ball runner blocks

High precision ball runner blocks have an innovative entry zone. The ends of the steel segments are not supported by the runner block body and can therefore deflect elastically. This entry zone adjusts individually to the actual operating load of the ball runner block. The balls enter the load-bearing zone very smoothly, i.e. without any load pulsation.

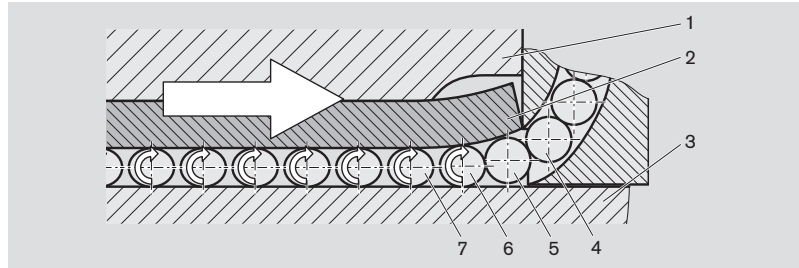

- |                     |                   |
|---------------------|-------------------|
| 1 Ball runner block | 3 Ball guide rail |
| 2 Steel segment     | 4-7 Balls         |

### Ball entry

- The balls (4) are guided to the beginning of the entry zone by the ball recirculation track.
- The ball (5) enters the zone load-free.
- The ball (6) causes the end of the steel segment to deflect elastically. This deflection is the sum of the compliance of the ball itself and the compliance of the unsupported end of the steel segment.
- As the distance between the steel segment and the rail becomes smaller than the ball diameter, the ball is gradually and uniformly subjected to loading (preload).
- The preload is thus smoothly increased until the ball (7) has reached its maximum preload.

### Innovative solution from Rexroth: ► the load-dependent entry zone

The functionality of the entry zone is key. The steel segments are manufactured with such precision that they deflect to the right degree in response to the actual load. This results in especially smooth ball entry behavior.

A ball deflects the precision-manufactured steel segment only as far as necessary to allow the following ball to enter load-free. The ball is no longer guided into the load-bearing zone in pulses by a rigid entry channel but by a very smooth flexing curve, which ideally transitions tangentially into the load-bearing zone.

The extremely smooth ball entry behavior and the continuous adjustment of the entry zone in response to the actual load are the great advantages of these high precision ball runner blocks.

### Characteristic features

- 1 Highest travel accuracy
- 2 Minimal frictional drag variation
- 3 The conflicting aims are resolved

High Precision Ball Runner Blocks made of steel

## Frictional Drag Variations

### Definition

The total frictional drag of a runner block is composed of the following components:

- 1 Ball friction
- 2 Seal friction
- 3 Friction in the ball recirculation elements and recirculation tracks

Variations in frictional drag can be especially troublesome in certain operating environments.

### These variations are mainly due to the following fact:

The balls have to transition from the load-free zone to the load-bearing zone. Through its innovative design, the smooth ball entry zone minimizes the variations, which also permits better control of the linear drive.

Frictional drag comparison for a size 35 ball runner block with an external load of 10,000 N

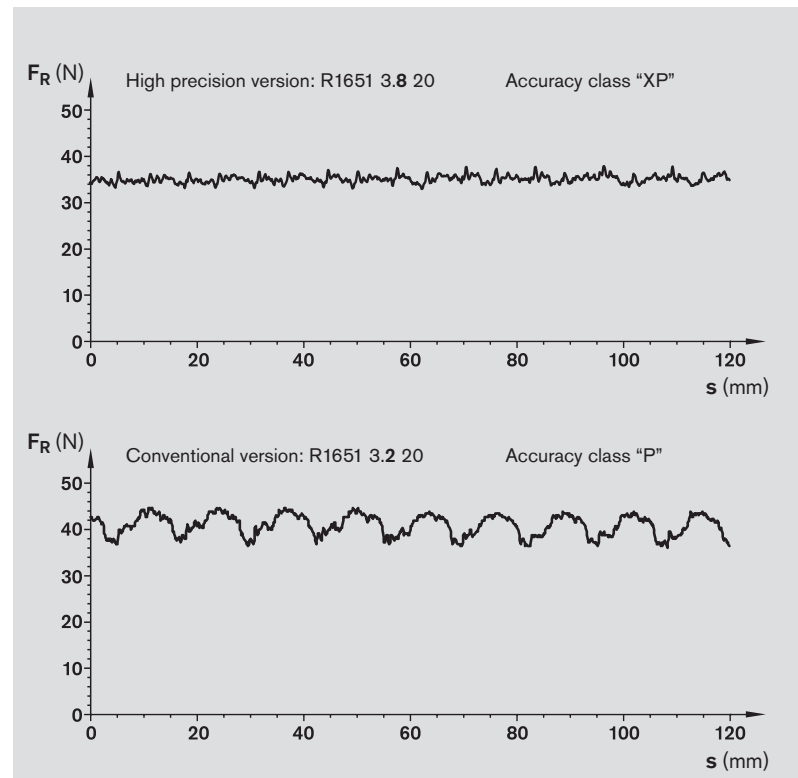

- ➡ Reduced frictional drag
- ➡ Significantly reduced frictional drag variation

# Travel accuracy

## Definition

Ideally, the ball runner block should move in a straight line along the guide rail in the direction of the X-axis. In practice, however, deviations occur in all six degrees of freedom. Travel accuracy is the term used to describe the closeness of the movement to the ideal straight line.

### The six different degrees of freedom

- 1 Vertical deviation  
(linear deviation in the Z-direction)
- 2 Yawing (rotation about the Z-axis)
- 3 Lateral deviation  
(linear deviation in the Y direction)
- 4 Pitching (rotation about the Y-axis)
- 5 Translation  
(linear motion in the X-direction)
- 6 Rolling (rotation about the X-axis)

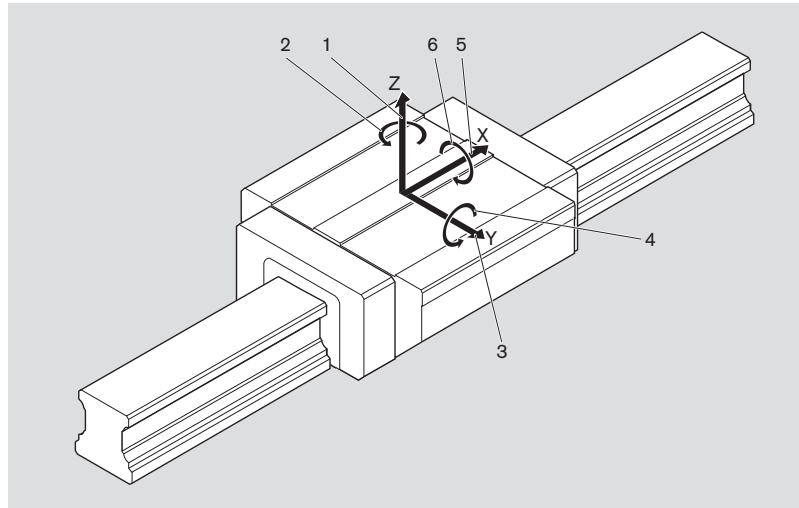

### Causes of travel inaccuracy

Travel accuracy is influenced by the following parameters:

- 1 The finish of the mounting base to which the rail fastened.
- 2 Parallelism errors between the contact surfaces of the rail and the ball running tracks.
- 3 Elastic deformations of the rail under the mounting screws.
- 4 Variations in accuracy as balls enter and exit the load-bearing zone.

### Optimization potential

- Re 1 Machine the mounting base for the guide rail with the greatest possible precision (beyond the control of Rexroth).
- Re 2 The deviation can be influenced by choosing an appropriate accuracy class for the rail.
- Re 3 Reduce the tightening torque. The tightening torque for the fastening screws has a proportional effect. Reducing the torque will lessen the compression of the rail material.  
 ➔ Reduced geometric variation in travel characteristics

**⚠ CAUTION: This may result in a decrease in the transmittable forces and moments.**

- Re 4 – The patented, innovative entry zone design of the Rexroth high precision ball runner blocks minimizes these accuracy deviations.

Potential further improvements:

- Use of long runner blocks
- Installation of additional runner blocks per rail

High Precision Ball Runner Blocks made of steel

## Travel accuracy

**The deviations measured are due to the following phenomenon**

A ball circuit contains a number  $n$  of load-bearing balls. When the ball runner block is moved in the direction of travel, a new ball engages in the entry zone. Now there are  $n+1$  load-bearing balls. This creates an imbalance between the four rows of load-bearing balls. Because the balls enter the load-bearing zones randomly, the runner block begins to rotate in an attempt to restore the balance. As the runner block moves further on, a ball leaves the load-bearing part of the circuit through the run-out zone. This again creates an imbalance between the four load-bearing ball circuits, which the runner block again attempts to correct by rotating. This effect is clearly shown in the diagram at right.

As demonstrated in practical applications, the shortwave inaccuracies have a period equivalent to approximately twice the ball diameter.

The remaining long-wave deviation is the result of the causes 1, 2 and 3 described earlier (mounting base finish, parallelism error, and elastic deformation of the rail under the fastening screws).

Distribution of forces in the runner block

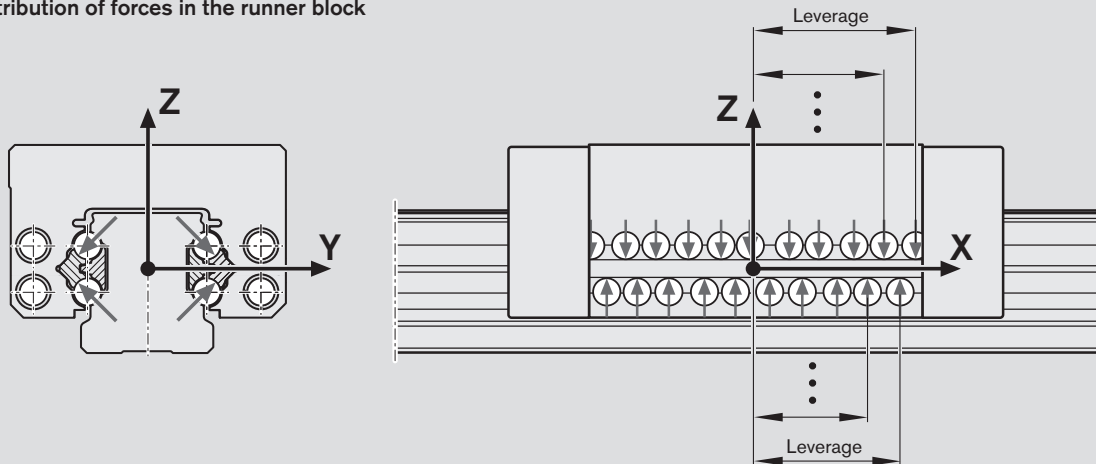

### Direct comparison of the travel accuracy of two ball runner blocks

The graph clearly shows that the short-wave inaccuracies (dashed line) can be very significantly reduced by the new, innovative design of the entry zone (continuous line).

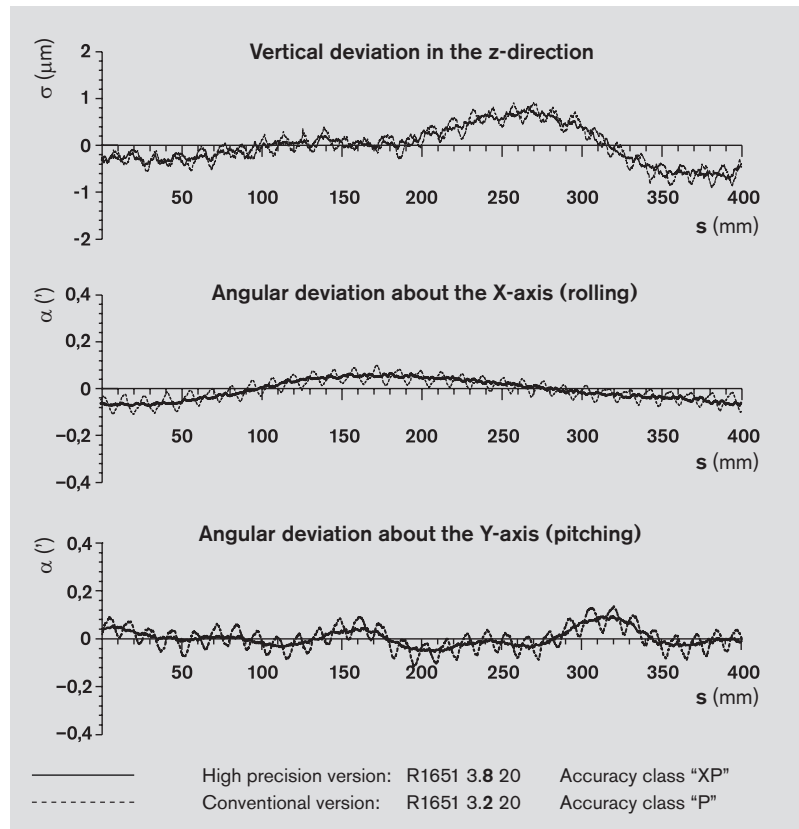

High Precision Ball Runner Blocks made of steel

## FNS, FLS

### FNS – Flanged, normal, standard height R1651 ... 2.

#### Dynamic characteristics

Travel speed  $v_{\max} = 5 \text{ m/s}$

Acceleration  $a_{\max} = 500 \text{ m/s}^2$

(If  $F_{\text{comb}} > 2.8 \cdot F_{\text{pr}}$ :  $a_{\max} = 50 \text{ m/s}^2$ )

#### Note on lubrication:

- Pre-lubricated

#### Note

Can be used on all Ball Guide Rails SNS.

#### Dimension drawing, dimensions and technical data 37.

#### Ordering example

Options:

- Ball Runner Block FNS
- Size 30
- Preload class C1
- Accuracy class XP
- With standard seal, without ball chain

Part number: R1651 718 20



#### Options and part numbers

Size	Ball runner block with size	Preload class			Accuracy class			Seal for ball runner block					
		C1	C2	C3	XP	SP	UP	without ball chain			with ball chain		
								SS	LS <sup>1)</sup>	DS	SS	LS <sup>1)</sup>	DS
15	R1651 1	1	2	3	8	1	9	20	21	–	22	23	–
20	R1651 8	1	2	3	8	1	9	20	21	2Z	22	23	2Y
25	R1651 2	1	2	3	8	1	9	20	21	2Z	22	23	2Y
30	R1651 7	1	2	3	8	1	9	20	21	2Z	22	23	2Y
35	R1651 3	1	2	3	8	1	9	20	21	2Z	22	23	2Y
45	R1651 4	1	2	3	8	1	9	20	–	2Z	22	–	2Y
e.g.	R1651 7	1			8			20					

### FLS – Flanged, long, standard height R1653 ... 2.

#### Dynamic characteristics

Travel speed  $v_{\max} = 5 \text{ m/s}$

Acceleration  $a_{\max} = 500 \text{ m/s}^2$

(If  $F_{\text{comb}} > 2.8 \cdot F_{\text{pr}}$ :  $a_{\max} = 50 \text{ m/s}^2$ )

#### Note on lubrication:

- Pre-lubricated

#### Note

Can be used on all Ball Guide Rails SNS.

#### Dimension drawing, dimensions and technical data 39.

#### Ordering example

Options:

- Ball Runner Block FLS
- Size 30
- Preload class C1
- Accuracy class XP
- With standard seal, without ball chain

Part number: R1653 718 20



#### Options and part numbers

Size	Ball runner block with size	Preload class			Accuracy class			Seal for ball runner block					
		C1	C2	C3	XP	SP	UP	without ball chain			with ball chain		
								SS	LS <sup>1)</sup>	DS	SS	LS <sup>1)</sup>	DS
15	R1653 1	1	2	3	8	1	9	20	21	–	22	23	–
20	R1653 8	1	2	3	8	1	9	20	21	2Z	22	23	2Y
25	R1653 2	1	2	3	8	1	9	20	21	2Z	22	23	2Y
30	R1653 7	1	2	3	8	1	9	20	21	2Z	22	23	2Y
35	R1653 3	1	2	3	8	1	9	20	21	2Z	22	23	2Y
45	R1653 4	1	2	3	8	1	9	20	–	2Z	22	–	2Y
e.g.	R1653 7	1			8			20					

1) Low-friction seal available for preload C1 (only for accuracy class XP)

#### Preload classes

C1 = preload 2% C

C2 = preload 8% C

C3 = preload 13% C

#### Seals

SS = standard seal

LS = low-friction seal

DS = double-lipped seal

#### Key to table

Gray numbers

= version/combination not preferred  
(longer delivery times in some cases)

## SNS, SLS

### SNS – Slimline, normal, standard height R1622 ... 2.

#### Dynamic characteristics

Travel speed  $v_{\max} = 5 \text{ m/s}$   
 Acceleration  $a_{\max} = 500 \text{ m/s}^2$   
 (If  $F_{\text{comb}} > 2.8 \cdot F_{\text{pr}}$  :  $a_{\max} = 50 \text{ m/s}^2$ )

#### Note on lubrication:

– Pre-lubricated

#### Note

Can be used on all Ball Guide Rails  
 SNS.

#### Dimension drawing, dimensions and technical data 43.

#### Ordering example

Options:

- Ball Runner Block SNS
- Size 30
- Preload class C1
- Accuracy class XP
- With standard seal, without ball chain

Part number: R1622 718 20

### SLS – Slimline, long, standard height R1623 ... 2.

#### Dynamic characteristics

Travel speed  $v_{\max} = 5 \text{ m/s}$   
 Acceleration  $a_{\max} = 500 \text{ m/s}^2$   
 (If  $F_{\text{comb}} > 2.8 \cdot F_{\text{pr}}$  :  $a_{\max} = 50 \text{ m/s}^2$ )

#### Note on lubrication:

– Pre-lubricated

#### Note

Can be used on all Ball Guide Rails  
 SNS.

#### Dimension drawing, dimensions and technical data 45.

#### Ordering example

Options:

- Ball Runner Block SLS
- Size 30
- Preload class C1
- Accuracy class XP
- With standard seal, without ball chain

Part number: R1623 718 20

#### Preload classes

C1 = preload 2% C  
 C2 = preload 8% C  
 C3 = preload 13% C



#### Options and part numbers

Size	Ball runner block with size	Preload class			Accuracy class	Seal for ball runner block						
		C1	C2	C3		without ball chain			with ball chain			
					XP	SS	LS <sup>1)</sup>	DS		SS	LS <sup>1)</sup>	DS
15	R1622 1	1	2	3		8	20	21	–	22	23	–
20	R1622 8	1	2	3		8	20	21	2Z	22	23	2Y
25	R1622 2	1	2	3		8	20	21	2Z	22	23	2Y
30	R1622 7	1	2	3		8	20	21	2Z	22	23	2Y
35	R1622 3	1	2	3		8	20	21	2Z	22	23	2Y
45	R1622 4	1	2	3		8	20	–	2Z	22	–	2Y
e.g.	R1622 7	1				8	20					



#### Options and part numbers

Size	Ball runner block with size	Preload class			Accuracy class	Seal for ball runner block						
		C1	C2	C3		without ball chain			with ball chain			
					XP	SS	LS <sup>1)</sup>	DS		SS	LS <sup>1)</sup>	DS
15	R1623 1	1	2	3		8	20	21	–	22	23	–
20	R1623 8	1	2	3		8	20	21	2Z	22	23	2Y
25	R1623 2	1	2	3		8	20	21	2Z	22	23	2Y
30	R1623 7	1	2	3		8	20	21	2Z	22	23	2Y
35	R1623 3	1	2	3		8	20	21	2Z	22	23	2Y
45	R1623 4	1	2	3		8	20	–	2Z	22	–	2Y
e.g.	R1623 7	1				8	20					

1) Low-friction seal available for preload C1

#### Seals

SS = standard seal  
 LS = low-friction seal  
 DS = double-lipped seal

#### Key to table

Gray numbers  
 = version/combination not preferred  
 (longer delivery times in some cases)

High Precision Ball Runner Blocks made of steel

## SNH, SLH

### SNH – Slimline, normal, high R1621 ... 2.

#### Dynamic characteristics

Travel speed  $v_{\max} = 5$  m/s

Acceleration  $a_{\max} = 500$  m/s<sup>2</sup>

(If  $F_{\text{comb}} > 2.8 \cdot F_{\text{pr}}$ :  $a_{\max} = 50$  m/s<sup>2</sup>)

#### Note on lubrication:

- Pre-lubricated

#### Note

Can be used on all Ball Guide Rails SNS.

#### Dimension drawing, dimensions and technical data 49.

#### Ordering example

Options:

- Ball Runner Block SNH
- Size 30
- Preload class C1
- Accuracy class XP
- With standard seal, without ball chain

Part number: R1621 718 20



#### Options and part numbers

Size	Ball runner block with size	Preload class			Accuracy class	Seal for ball runner block					
		C1	C2	C3		XP	without ball chain			with ball chain	
						SS	LS <sup>1)</sup>	DS	SS	LS <sup>1)</sup>	DS
15	R1621 1	1	2	3	8	20	21	–	22	23	–
25	R1621 2	1	2	3	8	20	21	2Z	22	23	2Y
30	R1621 7	1	2	3	8	20	21	2Z	22	23	2Y
35	R1621 3	1	2	3	8	20	21	2Z	22	23	2Y
45	R1621 4	1	2	3	8	20	–	2Z	22	–	2Y

e.g. R1621 7 | 1 | | | 8 | 20

### SLH – Slimline, long, high R1624 ... 2.

#### Dynamic characteristics

Travel speed  $v_{\max} = 5$  m/s

Acceleration  $a_{\max} = 500$  m/s<sup>2</sup>

(If  $F_{\text{comb}} > 2.8 \cdot F_{\text{pr}}$ :  $a_{\max} = 50$  m/s<sup>2</sup>)

#### Note on lubrication:

- Pre-lubricated

#### Note

Can be used on all Ball Guide Rails SNS.

#### Dimension drawing, dimensions and technical data 51.

#### Ordering example

Options:

- Ball Runner Block SLH
- Size 30
- Preload class C1
- Accuracy class XP
- With standard seal, without ball chain

Part number: R1624 718 20



#### Options and part numbers

Size	Ball runner block with size	Preload class			Accuracy class	Seal for ball runner block					
		C1	C2	C3		XP	without ball chain			with ball chain	
						SS	LS <sup>1)</sup>	DS	SS	LS <sup>1)</sup>	DS
25	R1624 2	1	2	3	8	20	21	2Z	22	23	2Y
30	R1624 7	1	2	3	8	20	21	2Z	22	23	2Y
35	R1624 3	1	2	3	8	20	21	2Z	22	23	2Y
45	R1624 4	1	2	3	8	20	–	2Z	22	–	2Y

e.g. R1624 7 | 1 | | | 8 | 20

1) Low-friction seal available for preload C1

#### Preload classes

C1 = preload 2% C

C2 = preload 8% C

C3 = preload 13% C

#### Seals

SS = standard seal

LS = low-friction seal

DS = double-lipped seal

#### Key to table

Gray numbers

= version/combination not preferred  
(longer delivery times in some cases)

## Application Examples

Rexroth High Precision Ball Runner Blocks are especially suited for the following applications:

### 1 Measuring

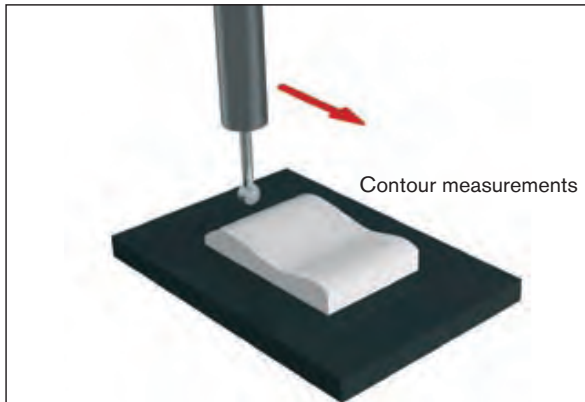

3D coordinate measuring machine

### 4 Milling

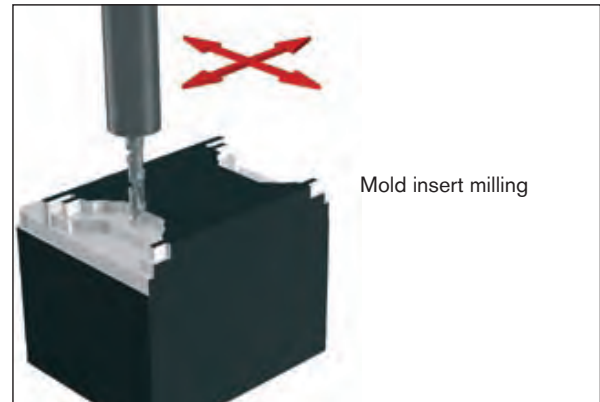

Hard milling

### 2 Grinding



Internal cylindrical grinding

### 5 Turning

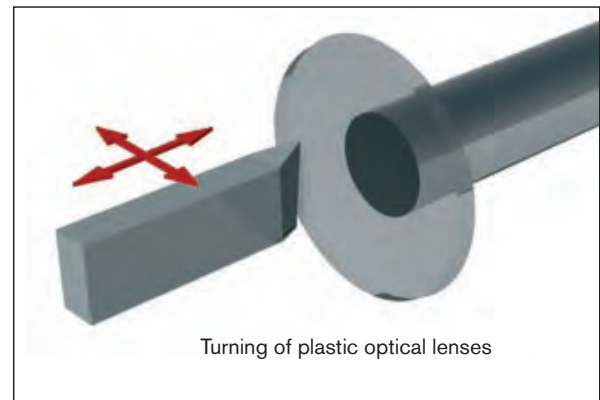

High precision turning

### 3 Electrical discharge machining (EDM)

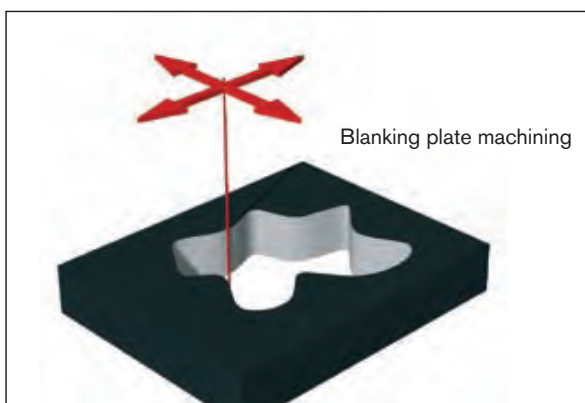

Wire EDM

### 6 Microelectronics

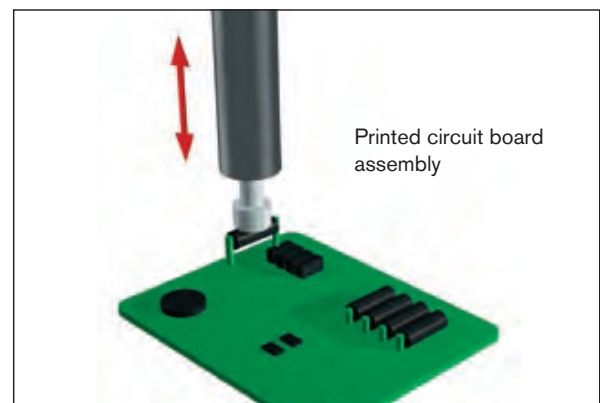

PCB assembly machines

These are just a few examples of the many possible applications. Simply ask us. We'll find the right solution for your needs.