

PLC
IndraLogic XLC

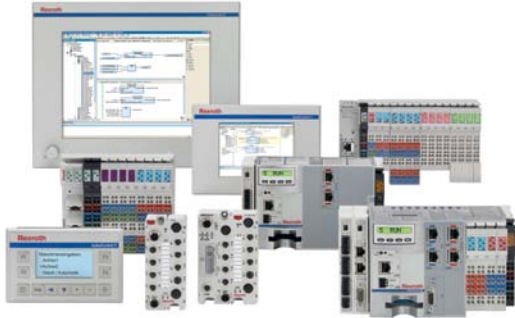

PLC
IndraLogic XLC

Documentation
• Documentation



- Cutting-edge control hardware with numerous extension options
- The latest PLC kernel IndraLogic 2G (based on CoDeSys V3)
- High-performance communication via RT Ethernet SERCOS III for all peripherals
- Synchronized motion control functionality
- IndraWorks The Tool for All Engineering Tasks

The new IndraLogic XLC (eXtended Logic Control) PLC system implements the latest PLC technology to provide substantial advantages for the intelligent automation of production tools and systems. IndraWorks software offers a full integration of all necessary tools and a noticeable reduction in the engineering process chain. Object-oriented language extensions in programming enhance the quality of user programs through simplified modularization and accelerate the generation of machine variants.

Scaling and open design of the IndraControl device families are the basis for flexible and application-oriented solutions in central or distributed control topologies. The universal, open real-time communications system sercos III is the high-performance, high-functioning backbone among the system peripherals.

Application-oriented task setting of the high-performance Motion-Logic runtime system permit both rapid I/O signal processing and highly dynamic motion control tasks. Consistent system information and transparent diagnoses throughout the system minimize downtimes and provide a tangible increase in productivity for a wide range of applications and processes.

Technical data

		IndraLogic XLC L25	IndraLogic XLC L45	IndraLogic XLC L65
Control units				
Runtime system	Integrated motion logic system	●	●	●
Multitasking		●	●	●
Data management	Code, data, retentive data, user data	●	●	●
Storage	Boot project	●	●	●
	PLC project as packed archive file	●	●	●
	User data to the internal memory and a removable storage medium	●	●	●
Support	Function modules	2	4	4
	System events	●	●	●
Probe		●	●	●
User memory	Total: code, data	12 MB	24 MB	36 MB
Retentive memory	Total: system, user	256 kB	256 kB	256 kB
On-board diagnosis and settings				
Status display (boot, sercos, test)	Display	●	●	●

PLC

IndraLogic XLC

Errors, warnings, messages, system reset		●	●	●
Ethernet settings (IP address)		●	●	●
Voltage monitoring, watchdog		●	●	●
Relay output ready for operation		●	●	●
IndraMotion Service Tool		○	○	○
Interfaces on board				
sercos III	Automation Bus	○	○	○
PROFIBUS	Master	○	●	●
	Slave	○	●	●
PROFINET IO	Controller (Master)	○	○	○
	Device (Slave)	○	○	○
EtherNet/IP	Scanner (Master)	▼	▼	▼
	Adapter (Slave)	○	○	○
Ethernet TCP/IP		●	●	●
Control grouping	Ethernet TCP/UDP/IP	●	●	●
Function modules				
Number		2	4	4
Realtime-Ethernet/PROFIBUS		○	○	○
Programmable limit switch		○	○	○
Fast I/O		○	○	○
HMI				
IndraControl VCP, VCH	Ethernet TCP/IP, OPC	○	○	○
IndraControl VEP, VEH	Ethernet TCP/IP, OPC	○	○	○
IndraControl VSP, VPP, VSB/VDP, VPB/VDP	Ethernet TCP/IP, OPC	○	○	○
Inputs/outputs				
On board				
Fast digital inputs	Interruptible, typ. 50 μ s	0	8	8
Fast digital outputs	0,5 A, typ. 500 μ s	0	8	8
Local				
Fast digital inputs (function module FAST I/O)	Interruptible, typ. 40 μ s	○	○	○
Fast digital outputs (function module FAST I/O)	0,5 A, typ. 70 μ s	○	○	○
Inline (digital, analog, relais, technology)	64 Byte, max. 512 E/A	○	○	○
Distributed via Inline (IP20)				
sercos III	On board / function module	○	○	○

PLC

IndraLogic XLC

PROFIBUS	On board / function module	○	○	○
Distributed via Fieldline (IP67)				
PROFIBUS	On board / function module	○	○	○
Distributed via IndraControl S67				
sercos III	On board / function module	○	○	○
PROFIBUS	On board / function module	○	○	○
Logic-Control				
PLC runtime system				
IndraLogic 2G kernel	Conforming with IEC 61131-3 with extensions	●	●	●
Program organization	According to IEC 61131-3	●	●	●
Loading and executing IEC 61131-3 applications		●	●	●
Task management				
Freely configurable tasks (priority 0-20)	Cyclic, free-running, event-controlled, externally event-controlled	8	8	8
Cycle-synchronous processing of the I/O process image		●	●	●
sercos III synchronous processing of the I/O process image		●	●	●
Min. PLC cycle time	Synchronous to the system cycle	1 ms	1 ms	1 ms
Min. motion cycle time	Setpoint generator	2 ms	1 ms	0.5 ms
PLC processing time				
Typical processing time for 1,000 instructions/ μ s	Command mix (Real, Integer, Bool etc.)	35	30	5
	Bool-Operation	20	30	5
	Word-Operation	20	30	5
Motion Control				
Number of axes	Real, virtual, encoder	16	32	64
Synchronization(ELS electronic line shaft)	Virtual axes(Virtual masters)	●	●	●
	Encoder axes(Real masters)	●	●	●
	Real axes(Servo drives)	●	●	●
	Dynamic synchronization	●	●	●
	Master axis cascading	●	●	●
Positioning	Single-axis	●	●	●
Electronic gears		●	●	●

PLC

IndraLogic XLC

Electronic cams	Intermediate point tables(In the drive, max. 1,024 intermediate points)	4	4	4
	Electronic Motion Profile(in the output drive, motion profiles with max. 16 segments)	2	2	2
	FlexProfile(In the control, master-/time-based motion profiles with max. 16 segments)	4	4	4
Motion commands according to PLCopen (choice)	MC_MoveAbsolute	●	●	●
	MC_MoveRelative	●	●	●
	MC_MoveVelocity	●	●	●
	MC_Home	●	●	●
	MC_CamIn, MC_CamOut	●	●	●
	MC_GearIn, MC_GearOut	●	●	●
Extended motion commands (choice)	MB_ReadListParameter	●	●	●
	MB_WriteListParameter	●	●	●
	MB_GearInPos	●	●	●
	MB_PhasingSlave	●	●	●
	MB_ClearAxisError	●	●	●
	MB_ClearSystemError	●	●	●
System functions (choice)				
Programmable limit switch	●	●	●	
PID controller	●	●	●	
Temperature controller	●	●	●	
Diagnostic				
Diagnosis(status, warning, error)	Function blocks(Software)	●	●	●
	Parameter access to diagnostics memory(Software)	●	●	●
	Locally via display(Control hardware)	●	●	●
	Axis monitoring(e.g. capacity, encoders, limit values)	●	●	●
	Diagnostics memory(64 kB, max. 999 messages)	●	●	●
Debugging monitor for IEC applications	●	●	●	
Drive systems				
Electric axes				
IndraDrive	●	●	●	

PLC
IndraLogic XLC

IndraDrive Cs		●	●	●
EcoDrive Cs		●	●	●
sercos Pack-Profile		●	●	●
Master communication	sercos III	●	●	●
Master communication	sercos II			
min. sercos III cycle time	Synchronous to the sercos cycle	1 ms	0.5 ms	0.25 ms
Engineering and Operation				
IndraWorks		○	○	○
IndraMotion Service Tool		○	○	○

Components

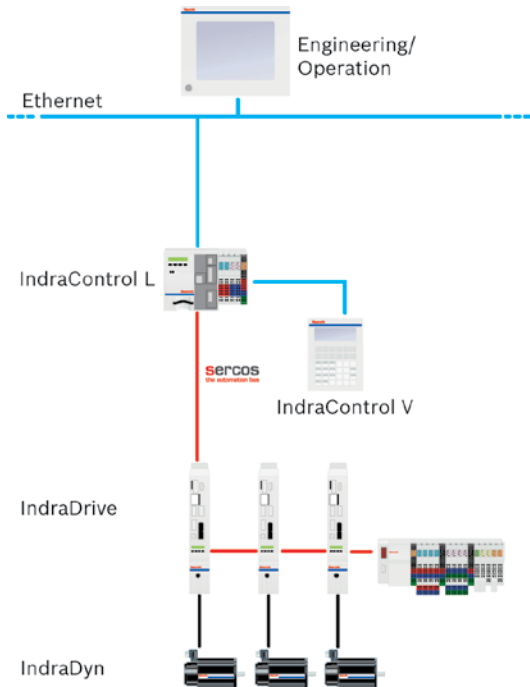

Engineering and operating

Description	Page
Engineering and operating	Software tools

Control hardware and interfaces

Description	Page
IndraControl L	IndraControl L25
IndraControl L	IndraControl L45
IndraControl L	IndraControl L65

PLC

IndraLogic XLC**HMI**

Description	Page	Details
HMI	Hand-held operator panel	IndraControl VxH
HMI	compact operator terminals	IndraControl VCP
HMI	Embedded PC	IndraControl VEP
Industrial PCs	Box-PC / Displays	IndraControl VPB and VDP
Industrial PCs	Panel-PC	IndraControl VPP PC solution for high-end industrial requirements

I/O

Description	Page	Details
IP 20	Inline	
I/O	IP 67	Fieldline, IndraControl S67

Type code

Type code	Description	Part No.:
FWA-CML25*-XLC-12VRS-D0	Firmware IndraControl L25	R911334606
FWA-CML45*-XLC-12VRS-D0	Firmware IndraControl L45	R911334608
FWA-CML65*-XLC-12VRS-D0	Firmware IndraControl L65	R911334610

Bosch Rexroth AG

Postfach 13 57
97803 Lohr, Germany
Bgm.-Dr.-Nebel-Str. 2
97816 Lohr, Germany
Tel. +49 9352 18-0
Fax +49 9352 18-8400
www.boschrexroth.com/electrics

Local contact information can be found at:

www.boschrexroth.com/adressen

The data specified above only serve to describe the product. As our products are constantly being further developed, no statements concerning a certain condition or suitability for a certain application can be derived from our information. The information given does not release the user from the obligation of own judgment and verification.

It must be remembered that our products are subject to a natural process of wear and aging.