

GEVA 3000 Vision System



GEVA 3000

Benefits

- Turbo charged Core i7 processor for demanding applications
- Expandable camera solution drives down system cost
- Choice of application software suits user need and experience
- Full complement of vision capabilities for tackling challenging tasks
- Flexible camera interface supports area and line scan imaging
- Integrated factory communication protocols simplify 3rd party connections
- Industrial fanless enclosure allows operation in harsh environments

Overview

Flexible Machine Vision for the Factory Floor

GEVA 3000 is a compact industrial vision system with excellent performance for applications that need to inspect multiple features of a part or assembly. GEVA 3000 leverages expandable Gigabit Ethernet camera technology to significantly drive down system cost. The product's rugged, fanless design reduces downtime and maintenance costs associated with deploying standard PC solutions in harsh industrial environments.

GEVA 3000 is equipped with a low power, Gen3 Core i7 processor and high-speed system resources to effectively manage multi-camera applications. Each of the six (6) Gigabit compliant Ethernet ports internally connect through independent data lanes to alleviate bandwidth bottlenecks often associated with multi-camera acquisition. Each network port can be configured for either camera or network use and each can be expanded using external switches to accommodate larger camera or network configurations. GEVA 3000 network ports are compatible with a resolution range of mono or color area scan GigE cameras.

In addition to Ethernet, GEVA 3000 provides standard external interfaces for system integration, including display, 6 USB ports and a serial port. Camera triggering, I/O and lighting control is supported using a companion breakout module. The PL-USB module provides an easy and safe way to connect factory I/O to the GEVA 3000 and associated cameras.

Vision solutions on GEVA 3000 are setup using Teledyne DALSA's iInspect Express or Sherlock application software. The iInspect Express software is easy to use and requires little or no prior vision experience, while the Sherlock software offers greater flexibility to tackle more challenging inspection tasks. Both packages offer a full complement of tools, together with interfacing and control options for both users and equipment. For performance migration, applications built on other Teledyne DALSA equipment with the same camera set up will also run on the GEVA 300 and GEVA 1000 platforms.

Fully functional software emulators are installed on the GEVA 3000 to allow users to develop or debug applications offline. The emulator maximizes machine up time during application development and maintenance.

GEVA 3000 Vision System



GEVA 3000

Specifications

- Storage: 60GB SSD
- Program: 8GB
- Processor: 3.2 Ghz Gen3 Core i7
- Camera/Network Ports: GigE x6
- Serial Communication: USB 2.0 (x6), RS232 (x2)
- I/O: 8 IN/12 OUT via PL-USB companion module
- Display: VGA to QXGA (2048x1536/75Hz)
- Power: 24V (60W) via screw terminal connector
- Temp: 0-45C Operating
- Cooling: Fanless via passive heatsink
- Size: 277 x 89 x 194 mm
- Mounting: Panel mount
- Certifications: CE, FCC Class A, RoHS

Choice of Application Software

iNspect Express

iNspect Express offers a simple point and click interface that allows users to rapidly setup and deploy vision solutions. iNspect's logical navigation and practical features appeal to both experienced and new users alike.

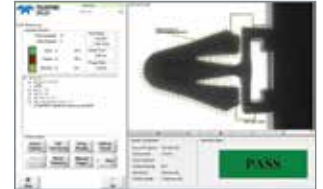

Sherlock

Sherlock offers additional flexibility and advanced features for tackling challenging applications. Sherlock's programmability appeals to the more experienced vision integrators, allowing mixing of camera technologies within the same application, advanced scripting and GUI customization.



General

Both software products offer a full suite of vision tools and capabilities to satisfy a broad range of automated tasks.

I/O Interfacing using the PL-USB

The PL-USB is an external I/O module that provides trigger and power to the connected Genie cameras as well as I/O for discrete application control. The PL-USB module simplifies hardware setup and provides a consistent I/O solution for iNspect Express and Sherlock application software. The product is DIN mountable and connects to the GV 3000 through a single USB cable.

Typical GV3000 configuration with the PL-USB

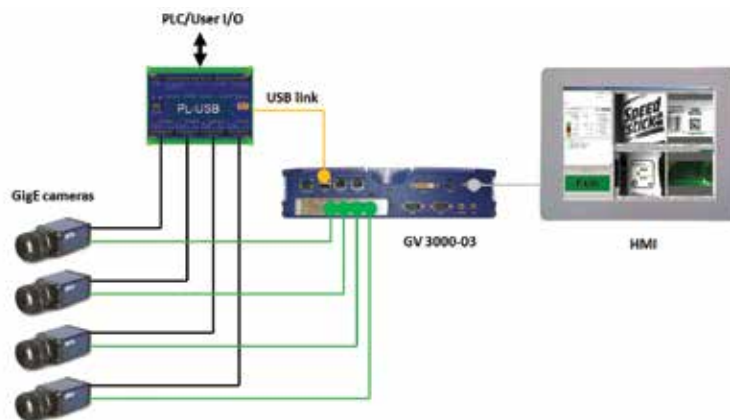

www.teledynedalsa.com

Americas

Boston, USA
+1 978 670-2002
sales.ipd@teledynedalsa.com

Europe

Krailling, Germany
+49 89 8954 57 30
sales.europe@teledynedalsa.com

Asia Pacific

Tokyo, Japan
+81 3-5960-6353
sales.asia@teledynedalsa.com

Shanghai, China
+86 21-3368-0027
sales.asia@teledynedalsa.com