

Lighting Geometries for Effectively Illuminating Cylindrical Surfaces

October 23, 2007

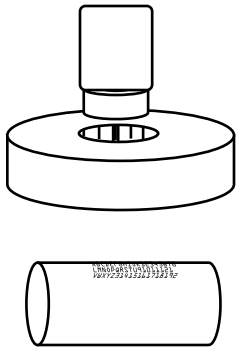

Fig. 1a

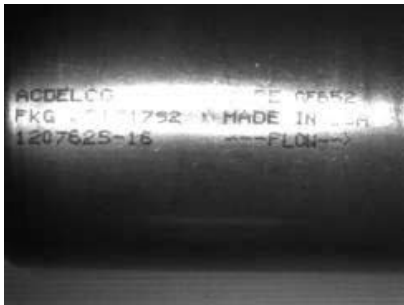

Fig. 1b

Not all surfaces respond similarly to standard direct illumination techniques. Surface color, texture, shape and composition can all influence where and how much light is reflected back into a vision camera. For example, when examining print for OCV or OCR applications, different surface shapes and reflectivity values can greatly affect the inspection results. One particularly difficult application is uniformly and consistently illuminating the surface of a highly specular cylinder for print OCR, in this example, a metal inline fuel filter. The print is a dot matrix type using black ink, and the printing direction is parallel to the cylinder's long axis.

Most print reading applications are set up using a standard geometry with the camera perpendicular to the print, and using co-axial directional light, such as a standard ring light. This camera – sample – light geometry works well if the sample is composed of a

diffuse material, and is relatively flat, but in this instance the surface is not only specular, but also curved in one direction. Using a typical geometry, as depicted in Fig 1a, produces an unsatisfactory, non-uniform image (Fig. 1b).

The 3-D envelope that includes the spatial relationships among camera – sample – light, in the case of the set up indicated in Fig. 1a, is really a 2-D geometry because the light is co-axial with respect to the camera. As the camera – sample orientation must remain the same, it would be appropriate to explore changing the orientation of the light, relative to the camera and sample.

Moving the ring light off-axis, away from the camera, but along the cylinder's curvature (Fig. 2a), similarly generates a slightly improved, but still unsatisfactory image (Fig. 2b). The image may be readable in its present form, but this geometry does not allow for any difference in sample

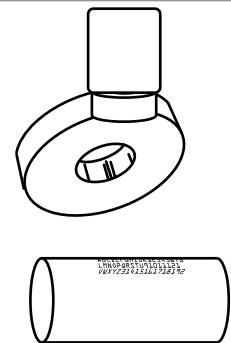
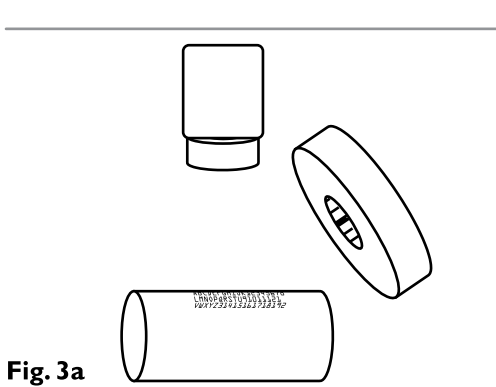

Fig. 2a



Fig. 2b

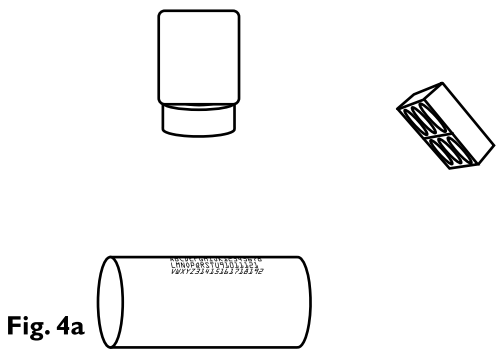
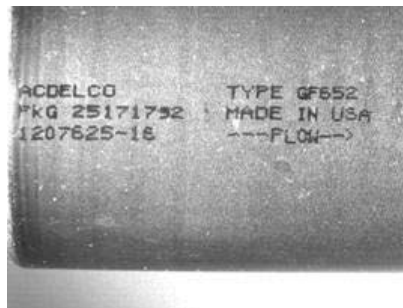

Fig. 3a

placement, thus it is not robust. If we examine the geometry in more detail, we see that, whereas we have changed the sample – camera geometry, we have not appreciably changed the sample – light geometry with respect to the cylinder axes.

Thus, by moving the light off-axis from the camera, AND off-axis, but co-planar to the cylinder long axis, we generate a consistent, uniform, and robust image (Fig. 3a & 3b).

Fig. 3b

One consequence of moving the light off-axis (i.e. – out of the co-axial position) is a certain loss of maneuvering room near the sample. This can also be overcome by using a high-current, high-brightness spot light, such as the AL084, at a longer (2X or greater) WD, but in a similar geometry (Figs. 4a & 4b).

Fig. 4a

Fig. 4b

About Ai

A lighting solutions company, Advanced illumination is based in Rochester, VT and manufactures a full line of LED-based lighting products and industry-leading control electronics, primarily for industrial vision inspection. Our technologies include Evenlite LED sorting and aiming; Signatech and Signatech 2 LED protection for maximizing both light output and LED life.

Ai sells through a world-wide network of distributors and strategic vision partners. Standard products ship same day; Standard variations offer customized options in two weeks. We also provide Free lab services and evaluation products for on-site testing.

For more information, visit us on line at the address below, or call 802.767.3830

The Light Used in this Application



AL084

Available colors: Blue, Green, Red & White