

# Safety Sensors and Switches

Meet existing safety standards!  
Supervise doors and hatches!  
Safe stops and reliable restarts!



Why should I use Safety Sensors and Switches? .....	8:2
Eden provides the Highest Safety Level and Reliability .....	8:3
How safe is a Sensor/Switch? .....	8:3
Eden Non-Contact Safety Sensor .....	8:4
SafeSlide™ Safety Lockout System .....	8:8
JSNY5 Safety Interlock Switch .....	8:10
JSNY7 Magnetic Switch .....	8:12
Solenoid Locking Safety Interlock Switches	
JSNY8 .....	8:14
JSNY9 .....	8:16
Magne 1A/2A Magnetic Lock with Indication .....	8:18
Knox Safety Lock .....	8:24
Component List and Ordering Information .....	8:28

# Why should I use Safety Sensors and Switches?

## ...to supervise doors and hatches around dangerous machines!

Assurance that a machine stops when a door or a hatch is opened can be solved by using different types of switches and sensors which are monitored with a Safety Relay, Vital 1 or Safety PLC. Switches and sensors are available both as non-contact (dynamic or magnetic) and various types of interlocking devices. Interlocking devices can be used when it is required, via a signal, to lock a gate during processes that cannot be stopped during certain operations. They are also used with machines that have a long stopping time.



## ...to manage safety in harsh environments!

Non-contact dynamic sensors have a long life-time because they are not physically mechanically operated. They also endure very harsh environments (i.e. cold, heat, high-pressure wash-down) which is important in the food industry. Because the sensors are small, they are very easy to position and even completely conceal on doors and hatches.



## ...to ensure that a position is reached!

The sensor monitors that the robot is standing still in a monitored position when someone enters the robot's working area. The robot is then only stopped by the program. If the robot leaves the position, the power will directly be cut. This is used when the robot does not stop safely without restarting problems.

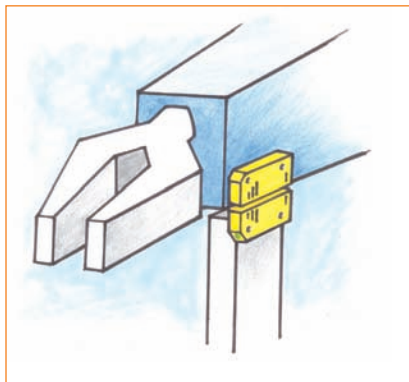

## Eden provides the Highest Safety Level and Reliability

Our recommendation is to use the Eden sensor because it is the safest and most reliable solution. The Eden sensor is both a non-contact switch and it has a dynamic function. It is also possible to connect up to 30 Eden sensors in series and still achieve a safety category 4.

### What requirements should one have on sensors/switches?

The sensor/switch shall be reliable in both the safety and production point of view.

- A person must be able to trust that dangerous movements and functions are safely stopped by the sensors/switches.
- In the production point of view, unintentional stops should be avoided.

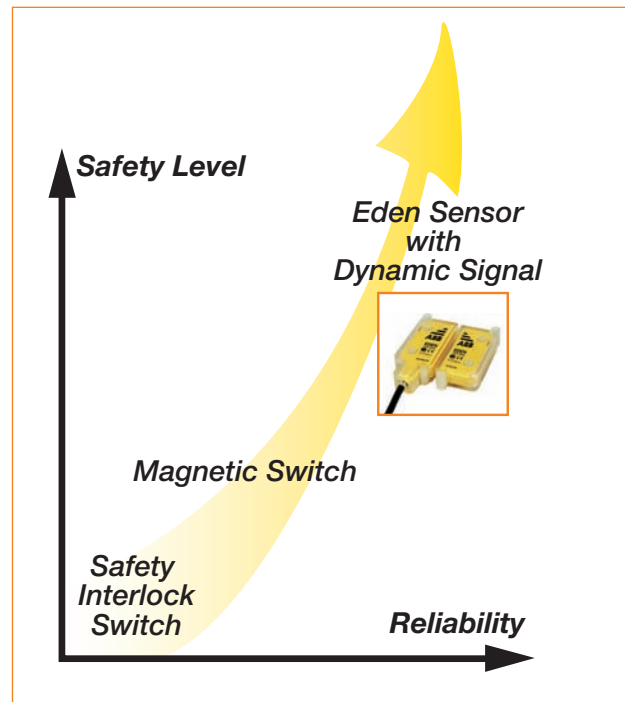

## How safe is a Sensor/Switch?

*In order to trust the safety function, it is essential to be aware that a safety sensor/switch must be mounted and used according to the specifications. The certification authorities only test the product according to the appropriate standards and to the specifications from the manufacturer.*

### Mechanical Switches

For mechanical switches (e.g. key operated), a door or hatch has to be constructed to small tolerances in order for the switch, the key or the mounting brackets to last according to the life time specification from the supplier. The screws holding the parts have to be locked in such a way that they cannot be loosened. In order to prevent material from getting into the slot for the key, the environment has to be clean.

If a door goes outside the design tolerances from wear, the screws loosen or material comes into the slot, this may lead to the interlocked switch not giving a stop signal when the door is opened. Even two mechanical switches on a door could break to an unsafe state if the door somehow gets outside the tolerances of the switches. To prevent accidents the mechanical switch normally needs continuous checks of both the switch and the installation.

### Non-Contact Sensors/Switches

For non-contact sensors the risks associated with mechanical switches do not exist. If screws, brackets or sensors get loose, it will lead to a stop signal. Therefore only one sensor with dual or dynamic function is needed in order to reach the highest safety level.

There are two types of non-contact sensors—active and passive. The active sensor, Eden, is constantly communicating with a dynamic signal between the two parts and any failure will directly lead to a stop signal. The passive type, a magnet switch, has two reed contacts which are activated by a coded magnet. Both the passive and the active sensors are checked every time a door is opened. From a safety point of view, the active sensor, Eden, is preferred because it is checked constantly whereas the passive sensor is only checked when a door opens.

From the reliability point of view, a long detection distance with large tolerances and a well-defined on and off position is needed. The active sensor, Eden, fulfills these demands. A magnet switch has smaller tolerances and an intermediate position where only one contact opens. A bad installation or vibrations can lead to an unintentional stop if one contact opens and closes again. The supervision of a two-channel system is based on both contacts having to be operated in order to permit a new start. In a dynamic safety circuit, there is only one pulsed signal and therefore no intermediate position.

# Eden Non-Contact Non-Magnetic Safety Sensor for the Highest Level of Safety

Eden—Adam and Eva—is a non-contact safety sensor for use on interlocked gates, hatches, etc. A coded signal is transmitted from the control device Vital or from the safety PLC Pluto via Adam to Eva, which modifies the signal and sends it back again. The maximum sensing distance between Adam and Eva is currently 15mm +/- 2mm.

Up to 30 Edens can be connected in series to Vital and still achieve the same safety level in the safety circuit. It is also possible to connect safety light beams and E-stops in the same safety circuit.

Adam is available with cable lengths up to 20 m and with M12 connectors. The LED on Adam provides indication of four different conditions, contact/non-contact between Adam and Eva, alignment, and safety status. The same information is also available via the Adam connection cable. For harsh environments, ABB Jokab Safety offers Eden E—Adam E and Eva E.

## Flexible Mounting

The ability to operate at distances of up to 15mm and at different detection directions allows a wide range of mounting possibilities.

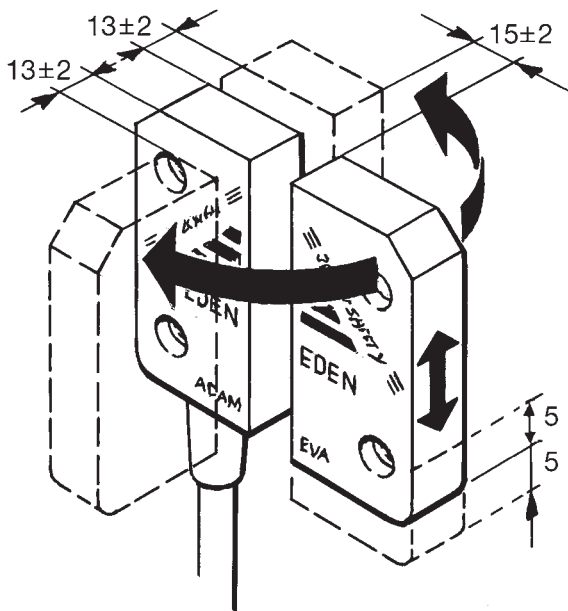

Eden E for harsh environments



## Applications

- Doors and Hatches
- Position Control
- Sector Detection
- Slot Detection

## Features

- Safety category 4 according to EN 954-1/EN ISO 13849-1 together with Vital or Pluto
- Non-contact detection, large sensing distance 0 - 15 mm +/- 2 mm
- Up to 30 sensors connected in series at safety category 4
- Versatile mounting, 360° detection
- Protection class IP67 (Eden E - IP69K)
- Signal will penetrate through non-metallic materials (wood, plastic, etc.)
- Safety light beams, E-stops and Eden can be connected in the same safety circuit together with Vital or Pluto meeting safety PLe according to EN ISO 13849-1
- LED indication on sensor and status information via the connector cable
- Small hysteresis (< 1mm)

## Approvals

TÜV Nord  

## Eden Application Examples

### Eden to Detect Position

Adam and Eva has contact only if they are within 15 mm from each other.

### Eden Used for Sector Detection

Metal stops the signal between Adam and Eva. Additional Eden sensor(s) can be mounted to detect metal plate(s) in place.

### Eden Used for Detection of Position of Saw Guard

Wood, plastic and other non-metallic material lets the signal pass between Adam and Eva.

### Eden Hidden in Doors and Hatches

Non-metallic door material between Adam and Eva allows signal through.

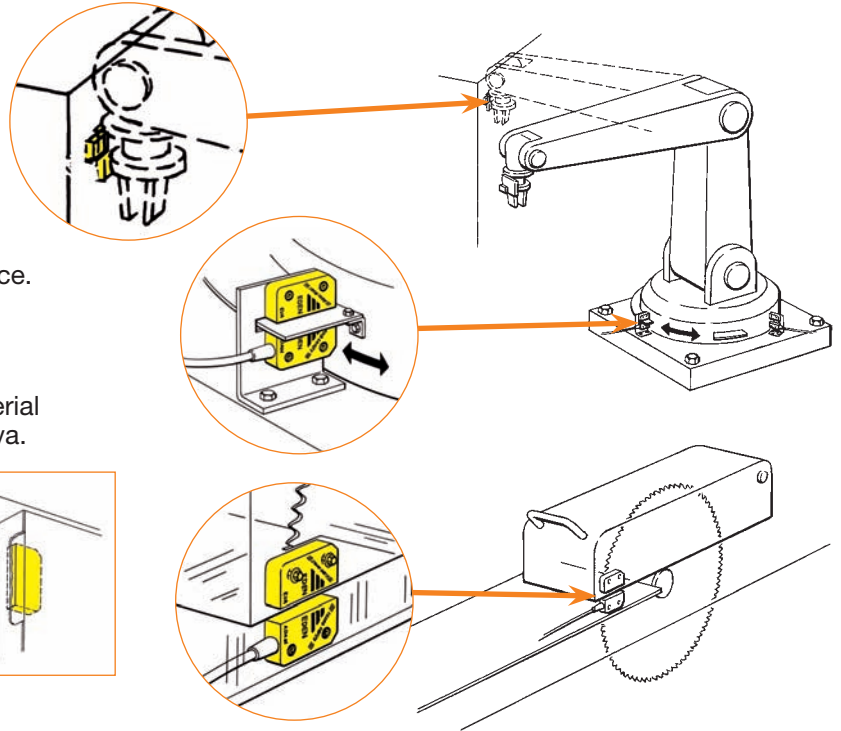

## Eden Mounting

Mounting Adam with integral cable.



Mounting with one protection plate (DA1) for Adam M12 using prewired molded M12 connector.



Mounting with two protection plates (DA1) for Adam M12 using field wirable M12 connector.

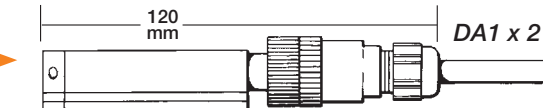

Incorrect mounting without protection plate may cause permanent damage to sensor.

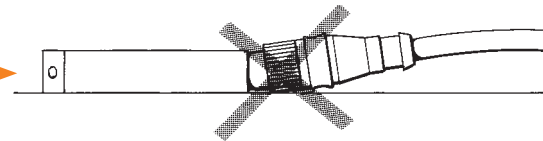

### DA2 Mounting Spacer

The DA2 mounting spacer must be used in order to physically protect Eden from damage. Four spacers are provided with each Adam and Eva.

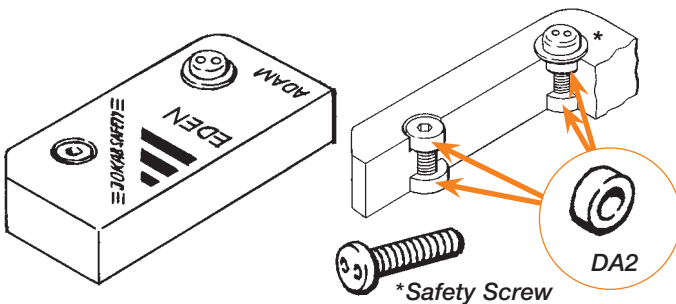

### DA1 Protection Plate

Four protection plates (2.5 mm) are supplied with Adam M12. To protect Adam and Eva protection plate (DA1) can be used on both sides.

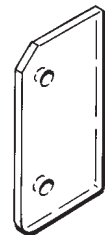

## Eden Technical Data

Manufacturer	ABB AB/Jokab Safety, Sweden	
Ordering information	see pages 8:28 - 8:30	
Safety level IEC/EN 61508-1...7 EN 62061 EN ISO 13849-1	SIL3 SIL3 Cat. 4/PL e	
PFH <sub>d</sub>	4.50×10 <sup>-9</sup>	
Color	Yellow and black	
Weight		
Eva	26 g	
Eva E	36 g	
Adam M12	30 g	
Adam 3 m	220 g incl. cable	
Adam 10 m	650 g incl. cable	
Adam 20 m	974 g incl. cable	
Adam E10 m	660 g incl. cable	
Adam E20 m	1250 g incl. cable	
Adam E 0.5 m + M12	100 g incl. cable	
Power supply	24VDC +15%-25%	
Power consumption	Adam: without info output 45 mA with info output max 55 mA	
Max cable length	see Vital technical data	
Ambient temperature Eden/Eden C	-40°C ... +70°C (operation) -25°C ... +70°C (stock)	
Eden E/EC	-40°C ... +70°C (operation) (Test ok +90°C ... +100°C) -25°C ... +70°C (stock)	
Protection class Eden Eden E	IP67 IP69K	
Mounting Installation Eden	M4 screw, e.g. safety screw 20-053-42. Max. torque 2 Nm. Screw to be locked with Loctite or similar	
Installation Eden E	M4 screw, e.g. safety screw 20-053-42. Max. torque 2 Nm. Screw to be locked with Loctite or similar	
Detection distance max Adam/Eva 15 ± 2 mm Adam E/Eva E 12 ± 2 mm Hysteresis approx. 1 mm	Flash 2 mm before red position Flash 2 mm before red position	
Metal may have influence on detection distance. This can be prevented by protection plates, DA1		
Minimum distance to metal when there is metal on one or more sides.		
Adam/Eva	One	More
Adam E/Eva E	0 mm	2.5 mm
Adam E/Eva E	0 mm	0 mm
Minimum distance between Eden pairs	50 mm	
Life	>10 <sup>7</sup> cycles	
Material	Macromelt (Based on polyamid) Eden E for extreme surroundings	
Cable	3 or 10 m, ø 5.7mm, black, PVC 5 x 0.34mm <sup>2</sup> + screen, UL 2464	
Connector	M12: 5-pin male contact	

Chemical resistance Macromelt	Cutting oils, vegetable and animal oils, hydrogen peroxide, diluted acids and bases: good Alcohol and strong acids: not recommended
PU (EdenE)	Cutting oils, vegetable and animal oils, hydrogen peroxide, diluted acids and bases, alcohols: good Strong oxidating acids: not recommended
LED on Adam Green	Eva within range, safety circuit closed (door closed)
Flashing	Eva within range, earlier safety circuit open (door closed)
Red	Eva out of range, safety circuit open (door open)
Fast flashing	Eva is within 2 mm from maximum sensing distance (door closed)
Connections	
Brown (1)	+24 VDC
White (2)	Dynamic signal in
Blue (3)	0 VDC
Black (4)	Dynamic signal out
Grey (5)	Info output, see below
24 VDC when LED is green or flashing (tolerance -2 VDC), 10 mA max 0 VDC when LED is red. (tolerance +2 VDC)	
<b>Warning:</b> Incorrect connection may cause permanent damage to Adam devices	
Conformity	2006/42/EG EN ISO 12100 1/2, EN 954-1, EN 60204-1, EN ISO 13849-1, EN 1088, GS-ET 15
Approvals	TÜV Nord <b>CE</b>

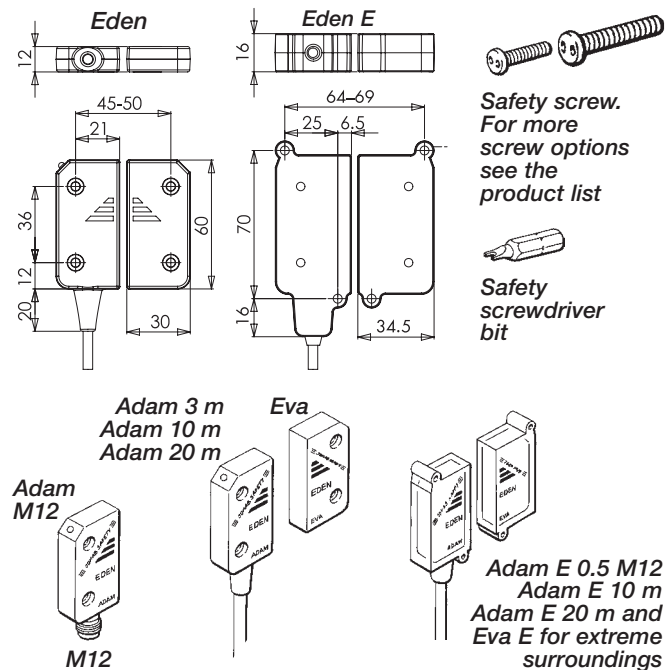

# Eden Connection Example

## Connection of Eden to Vital 1

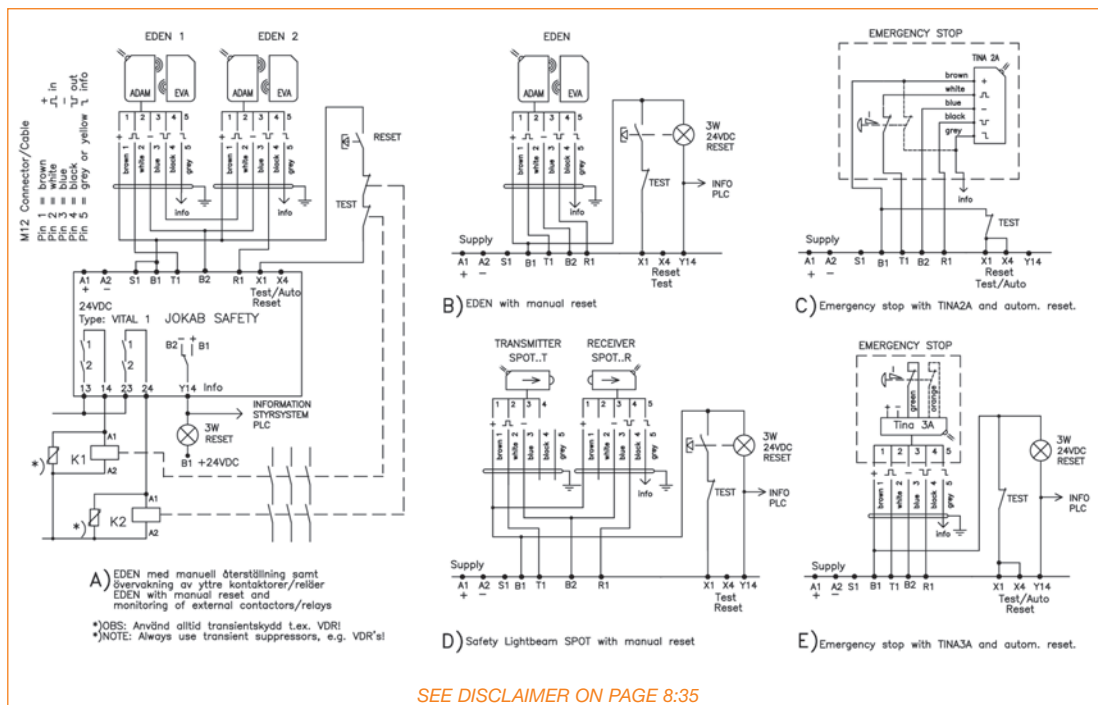

# Eden Connection Example

## Connection of Eden to Pluto

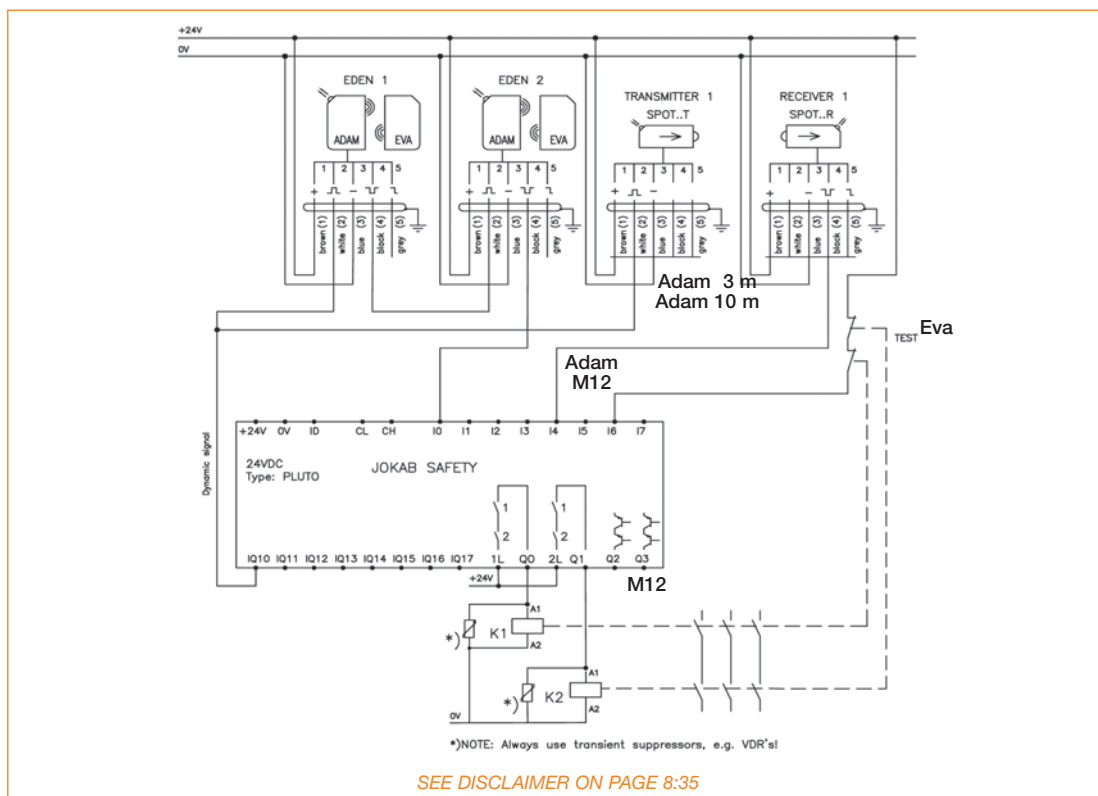

# SafeSlide™ Safety Lockout System

SafeSlide, a unique Safety Lockout System, was designed and developed by ABB Jokab Safety North America to be used in conjunction with ABB Jokab Safety's Eden non-contact, non-magnetic electronic safety sensor.

The product is engineered to be installed on doors, gates and hatches of all types used on machine guarding, barrier and fencing systems to provide safe entry and exit.

When the SafeSlide is engaged while the door is open and secured with a single or multiple padlocks, the system prevents the door from inadvertently closing which would cause the Eden Adam and Eva to reestablish contact creating an unsafe situation.

When the SafeSlide is engaged while the door is closed, it slides down over the flange on the bracket attached to the door and secures the door until the SafeSlide is disengaged.

The handle on the front of the slide allows for opening of the door, gate or hatch from the outside of the guarded area and a metal tab allows opening from the inside.

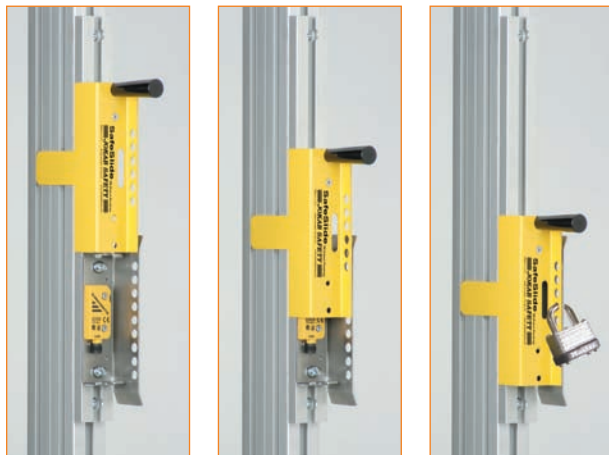

*When SafeSlide is engaged it completely eliminates the possibility of the Eden Adam and Eva making contact. A simple padlock can secure the position for further safety.*



*With the door closed and SafeSlide engaged, the Eden Adam and Eva are able to make contact and the door is secured.*



*With the door open and SafeSlide engaged, the Eden Adam and Eva are unable to make contact preventing an unsafe situation.*

## Applications

- Hinged or Sliding Doors, Hatches and Gates for Machine Guarding, Barrier and Fencing Systems

## Features

- Lock out holes for padlocks and scissor type lockout devices
- Mounting holes to accommodate installation of Eden—Adam and Eva Safety Sensor
- Adjustable slots for door, gate or hatch gap differences
- Upper slide with handle provides an automatic or manual lock cover upon opening of door gate or hatch
- Tabs located on device allow for wire and cable connections to the Eden switches
- Slots provided to allow viewing of LEDs located on the switches

## SafeSlide Technical Data

<b>Manufacturer</b>	ABB/Jokab Safety, North America
<b>Ordering information</b>	see page 8:30
<b>Color</b>	Yellow and black
<b>Weight</b>	1.9 kg
<b>Mounting</b>	Quick-Guard Fencing Profile (can be mounted to other handles or locking devices)
<b>Material</b>	Steel with UHMW slide block

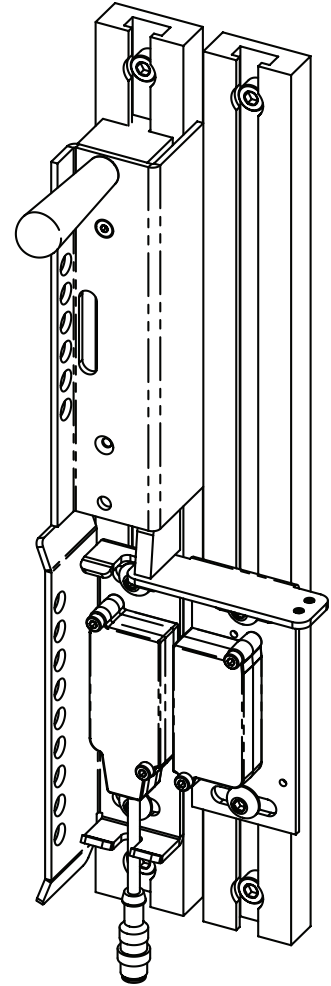
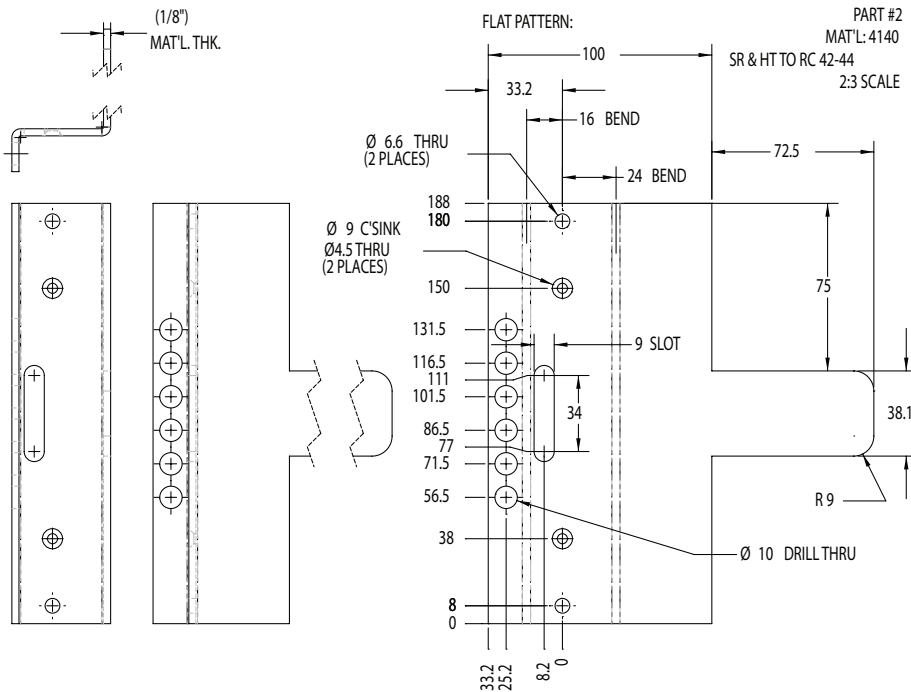

## SafeSlide Isolates Hazardous Motion and Offers Control Reliability during Non-Lockout/Tagout Applications

SafeSlide meets safety standards that apply to the control of energy during servicing and/or maintenance of machines and equipment.

Normal production operations are not covered by OSHA 1910 - Subpart O - Lockout/Tagout. Servicing and/or maintenance which takes place during normal production operations is covered by this standard only if one of these situations occurs:

- An employee is required to remove or bypass a guard or other safety device
- An employee is required to place any part of his or her body into an area on a machine or piece of equipment where work is actually performed upon the material being processed (point of operation) or where an associated danger zone exists during a machine operating cycle.

Minor tool changes and adjustments, and other minor servicing activities, which take place during normal production operations, are not covered by this standard if they are routine, repetitive and integral to the use of the equipment for production, provided that the work is performed using alternative measures which provide effective protection.

# JSNY5 Safety Interlock Switch

## Switch Operational Description

Increasing automation and more demanding safety regulations have led to the development of the JSNY5 safety switch. This switch enhances the range of Safety Switches, incorporating advanced features and benefits making this switch a market leader. This switch offers three contacts which gives both the two contacts needed for high safety level as well as a contact for the indication of operating status.

The advanced design offers the choice of four operating positions from only two actuator entries by simply rotating the head 180°.

However, when installed and in its working condition only one entry can be used, ensuring no other element can tamper with the switch function.

When mounting the switch from the front two elongated holes are provided to aid alignment with two set screw holes for accurate mounting. Top mounting is also possible.

Two M20 cable entries allow for a variety of cabling options including through wiring.

## Positive Forced Disconnected Contacts

The design assures that the contacts will not fail or be held in a normally closed position, due to failure of the spring mechanism or the welding/sticking of the contacts.

## Safety Level

The positive forced disconnect contacts give a high electrical safety level. By combining the JSNY5 with one of our suitable safety relay in the RT-series, Pluto Safety PLC or Vital (Tina) the requirements for both hatch and gate switch supervision can be fulfilled. To obtain the same level of safety as Eden, two switches per gate are required.

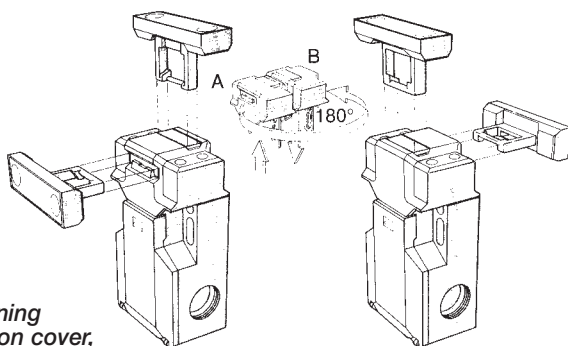

After opening the snap-on cover, the head portion can be removed (version A), after turning the head through 180° (version B) it can be replaced onto the body of the switch and be locked into position by closing the snap-on cover. This ensures 4 actuating positions are possible.



## Applications

- Gates and Hatches
- Removable Cover

## Features

- 2 NC + 1 NO (actuator in)
- 4 actuating positions
- Actuator force 10 or 30 N

## Protection from Unauthorized or Incidental Access

To avoid unauthorized operation, the JSNY5 switch is manufactured using multi-coding to GS-ET 15. The switch cannot be defeated by screwdrivers, magnets or any other mechanism.

## Connection Examples

For examples of how our safety switches can solve various safety problems, see "Connection Examples" beginning on page 4:44 of the Safety Relay Section.

## Regulations and Standards

The JSNY5 is designed and approved in accordance with appropriate directives and standards. Examples of such are: 98/37/EC, EN ISO 12100-1/-2, EN 60204-1 and EN 954-1/EN ISO 13849-1, EN 1088 and GS-ET 15.

## Approvals



## JSNY5A/B Technical Data

Manufacturer	ABB AB/Jokab Safety, Sweden
Ordering information	see page 8:30
Color	Black and yellow label
Enclosure/Cover	PA 6 (UL94-VO)
Actuator	Steel
Min. opening radius for actuator on a hatch	150 mm
Ambient operating temperature	-30°C to +80°C
Contacts (actuator key inserted)	2 NC + 1NO (NC are direct opening action)
Mechanical life	1 million switch operations
Max switching frequency	30/min
Fixing	body 2 x M5, actuator 2 x M5
Cable entry	2 x M20 x 1.5
Weight	approx. 0.13 kg
Degree of protection	IP65 IEC 60529 / DIN VDE 0470 T1
Rated insulation voltage	400 V AC
Rated operational current	5A
Utilization category	AC-15/DC-13
Short-circuit protection	Fuse 6A Slow acting, 16A quick acting

CSA	5A 300V AC B300 (same polarity)
B <sub>10d</sub>	JSNY 5A: 2.00×10 <sup>6</sup> JSNY 5B: 2.00×10 <sup>6</sup>
Conformity	2006/42/EG EN ISO 12100 1/2, EN 954-1, EN 60204-1, EN ISO 13849-1, EN 1088, GS-ET 15

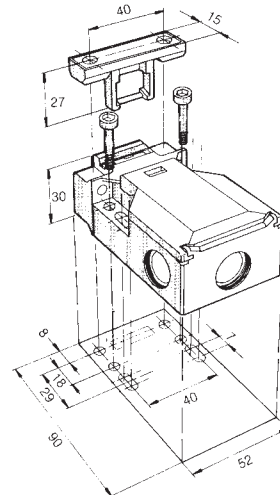

## JSNY5A/B Contact Description

### Overlapping Contact 33-34

The overlapping contact 33-34 enables operational status indication of e.g. incorrect adjustment of switch before the positive forced disconnect NC contacts open.

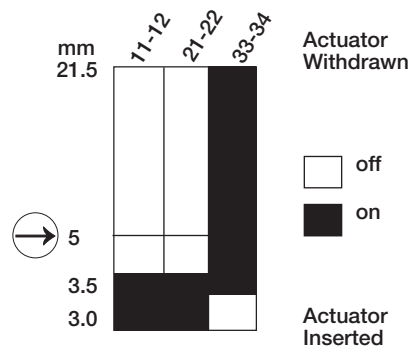
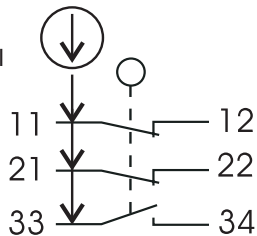

## Accessories and Spare Parts

- Standard actuator
- Flexible key for smaller opening radius
- Cable gland
- Snap-on cover
- Tina 2A with M20 connection for a dynamic loop
- Tina 2B with cable connection
- Tina 3A with M12 and M20 connections for a dynamic loop

## JSNY5A/B Assembly

### Easy Accessibility for Wiring

The snap-on cover is released by a screwdriver and can be opened to an angle of 135° providing easy access to the wiring terminals. Should the snap-on cover not provide adequate security, a retaining screw can be used.

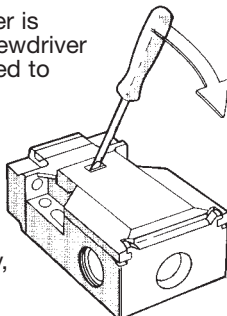

### Protected Contact Block

A transparent cover protects the contact block from external elements during the installation and wiring process.

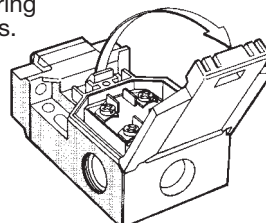

### Prevention of Actuator Dismantling

A cover plate with a one-way snap-fit which seals the mounting screws prevents unauthorized dismantling of the actuator assembly. The cover plate must be mounted to prevent overtravel of the switching mechanism.

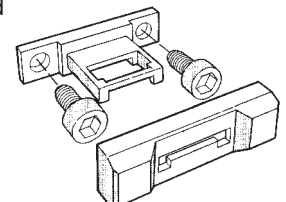

# JSNY7 Magnetic Switch

## Switch Operational Description

The magnetic switch is designed to operate in dirty industrial environments and is certified to the highest level of safety regulation when working together with a suitable ABB Jokab Safety safety relay.

The magnetic switch is small and resistant to both dirt and water, and has no dust collecting cavities making it useful in environments where hygiene is paramount. The small size of the switch makes it easy to position and hide on gates and hatches. The magnetic switch has a long working life since no mechanical contact is made during operation.

## Contacts

The magnetic switch has one closing and one opening contact. Both contacts have to be monitored. The contacts may be monitored by either the RT9 safety relay or other suitable relays in the new RT-series, i.e. RT6, RT9 or the Pluto Safety PLC.

## Safety Level

The JSNY7 is approved to the highest level of safety regulations, PLe according to EN ISO 13849-1 together with a safety relay in the RT-series or Pluto Safety PLC. The magnetic switch is approved and certified by Inspecta.

## Protection from Unauthorized or Incidental Access

To avoid unauthorized operation of the JSNY7 switch it is only possible to actuate the JSNY7R with the coded magnet, JSNY7M. Other magnets, screwdrivers and tools have no affect on the switch contacts.

## Connection Examples

For examples of how our safety switches can solve various safety problems, see "Connection Examples" beginning on page 4:44 of the Safety Relay Section.

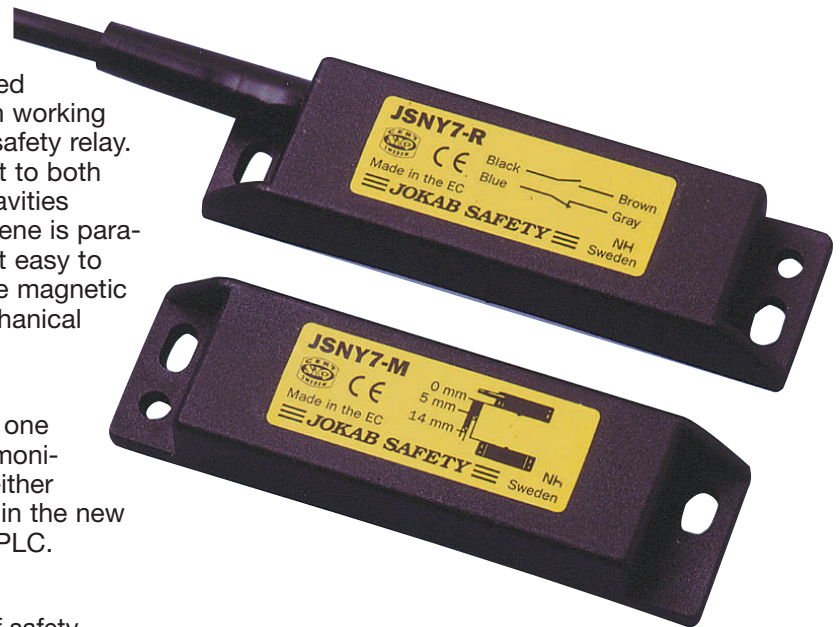

## Applications

- Gates and Hatches
- Position Control

## Features

- Small size
- IP 67
- Certified for highest level of safety regulations

## Regulations and Standards

The JSNY7 is designed and approved in accordance with appropriate directives and standards. See technical data.

## Approvals



## JSNY7 Technical Data

Manufacturer	ABB AB/Jokab Safety, Sweden
Ordering information	see page 8:31
Color	Black
Enclosure/Cover	PA 6 (UL94-VO)
Supply voltage max	30 VDC
Switch current max	100 mA
Max switching frequency	1 Hz
Mechanical life	3 x 108 switch operations, depending on load
Operating temperature range	-5°C to +70°C (moveable) -20°C to +70°C (fixed)
Connection	Cable $\varnothing 4.5$ , 4x0.25 mm <sup>2</sup> , 3 meter ; PVC (other lengths upon request)
Switching point	Min. switch-on point 5 mm Max. switch-off point 14 mm
Weight	Coded magnet: 32 g Sensor with 3m cable: 133 g
Protection class	IP67
B <sub>10d</sub>	JSNY 7R-3: 3.00x10 <sup>7</sup> JSNY 7R-6: 3.00x10 <sup>7</sup> JSNY 7R-10: 3.00x10 <sup>7</sup>

Conformity	2006/42/EG EN ISO 12100 1/2, EN 954-1, EN 60204-1, EN ISO 13849-1, EN 1088, GS-ET 15
------------	---

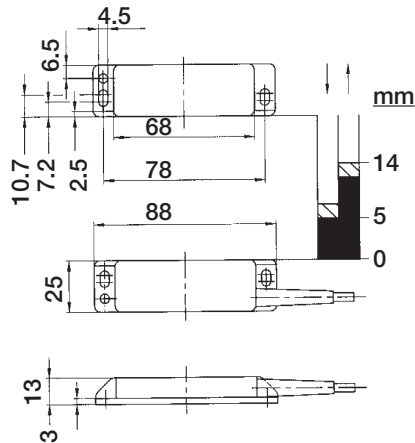

Electrical connection  
Two-channel switching, high safety level.

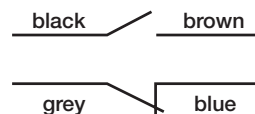

## JSNY7 Contact/Electrical Connection Description

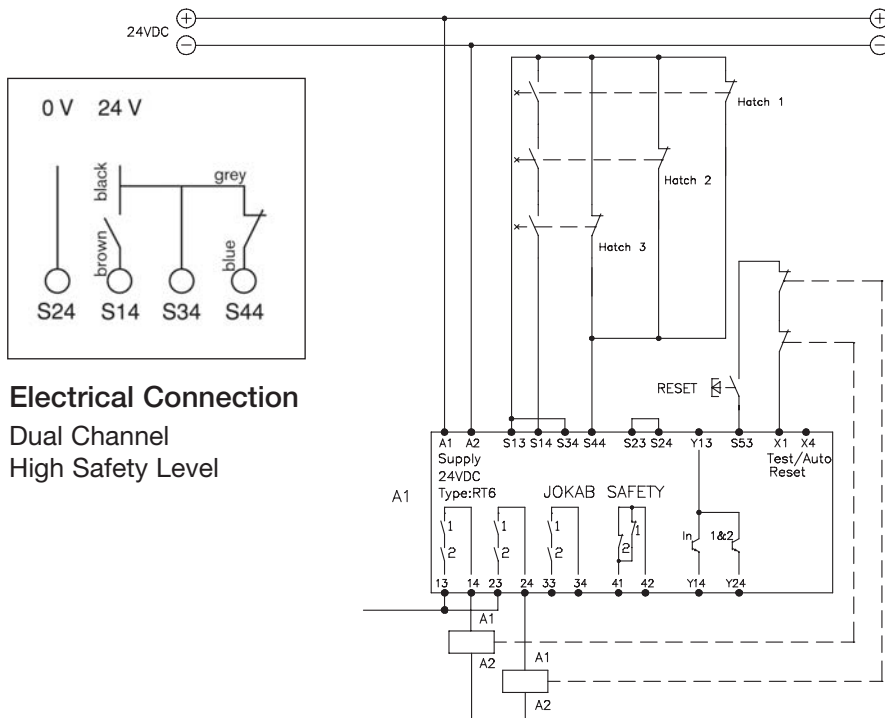

**Electrical Connection**  
Dual Channel  
High Safety Level

**Electrical Connection Example**  
Three JSNY7 connected to RT6 Safety Relay

*Note:*  
Safety components drawn in released position.

*This solution with 3 magnetic switches only complies with category 3 as per EN 954-1/EN ISO 13849-1.*

*To reach highest level of safety only one magnetic switch should be connected to the safety relay.*

# JSNY8 Solenoid Locking Safety Interlock Switch

## Description

The JSNY8 Safety Interlock Switch, in conjunction with the machine control system, enables gates, movable guards, etc. to be locked in their protective positions, thus preventing access to machinery until dangerous operations have ceased.

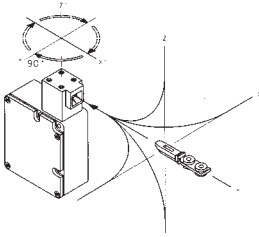

Applications include:

- Processes which cannot be interrupted, such as welding.
- Machinery with a long stopping procedure, such as paper machinery that requires a long braking operation.
- Prevention of unauthorized access to a particular area.

The JSNY8 has 2 + 2 NC positive force disconnection contacts. The first pair closes when the actuator key is pushed into the head. The other pair closes when the locking mechanism is in the locked position.

The head can be set in four positions, thus providing the safety device with four different operating positions. These are selected by twisting the head according to the instructions in the diagram above. The leading edges of the actuator key are reinforced and beveled in order to guide it properly into the hole. The JSNY8 is encased in a robust metal housing (IP67) providing a high level of protection to the internal operating components.

## Two Versions

The JSNY8 is available in two basic versions, either with a spring lock or a magnetic lock. In the spring lock (JSNY8S) version, the locking mechanism moves into the locked position directly when the door is closed and the actuator key is pushed into the lock. The actuator key can only be released and the gate opened by supplying operational voltage to the solenoid (E1-E2). The JSNY8S also has an emergency 'unlocking' facility to enable the actuator key to be released without the energization of the solenoid (E1-E2).

In the magnetic lock (JSNY8M) version, the locking mechanism is only in the locked position when the solenoid (E1-E2) is supplied with operating voltage. Release of the actuator key is only possible when the operating voltage is removed from the solenoid (E1-E2).

## Safety Level

The JSNY8 has double forced disconnection contacts to the actuator key and the locking mechanism. The actuator key has a triple coding design. To achieve maximum safety level in the connection to the machine's control system, it is recommended that the JSNY8 is monitored by an appropriate ABB Jokab Safety safety relay, Pluto Safety PLC or Vital. To obtain the same level of safety as Knox, two switches per gate are required.



## Applications

- Gates and Hatches

## Features

- Robust design
- Universal installation
- 2 NC + 2 NC outputs
- 1000 N locking force

## Tamper-Proof

The JSNY8 Safety Interlock Switch is tamper-proof. The safety device cannot be manipulated by screwdrivers, magnets or other tools.

## Connection Examples

For examples of how our safety switches can solve various safety problems, see "Connection Examples" beginning on page 4:44 of the Safety Relay Section.

## Regulations and Standards

The JSNY8 is designed and approved in accordance with appropriate standards. See technical data.

## Approvals

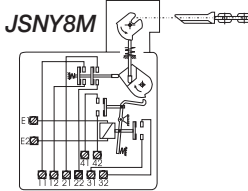
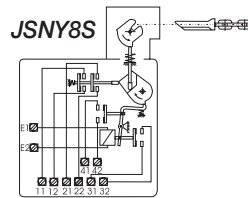

# JSNY8S/M Technical Data

Manufacturer	ABB AB/Jokab Safety, Sweden
Ordering information	see pages 8:31-8:32
Color	Black
Enclosure	Metal housing
Actuator key	Steel and plastic (PA6)
Min. operating radius for hatch	400 mm (smaller radius on request)
Actuator holding force	1000 N
Working temperature	-30°C to +60°C
Contacts actuator key inserted	2 NC
locking mechanism, locked position	2 NC
Mechanical service life	1 million switch operations
Installation fixings	3 x M5
Cable entry	2x M20 x 1.5
Weight	550 g
Enclosure class	IP67
Operating voltage	24V DC, 230 V AC
Rated insulation voltage	250V
Rated operating current	10A

Utilization category	AC 12 250V/10A AC 15 230V/4A
Short-circuit protection	Fuse 10A slow-acting, 16A quick-acting
Power consumption	5.2 W
B <sub>10d</sub>	JSNY 8M 24 VDC: 2.00×10 <sup>6</sup> JSNY 8M 230 VAC: 2.00×10 <sup>6</sup> JSNY 8S 24 VDC: 2.00×10 <sup>6</sup> JSNY 8S 230 VAC: 2.00×10 <sup>6</sup>
Conformity	2006/42/EG EN ISO 12100 1/2, EN 954-1, EN 60204-1, EN ISO 13849-1, EN 1088, GS-ET 19, EN 60947-5-1

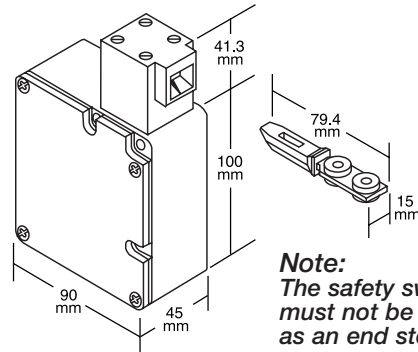

**Note:**  
The safety switch must not be used as an end stop!

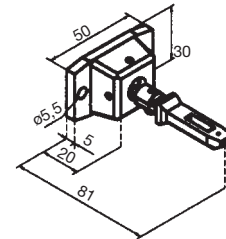
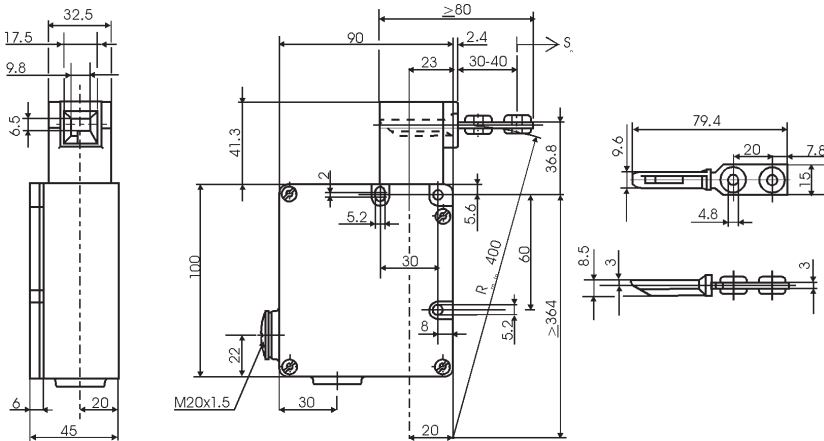

**JSNY8/9N2**  
Rmin: 150 mm  
Flexible actuator.

## JSNY8S/M Contact Description

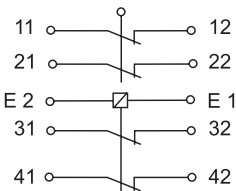

### JSNY8S

Key actuator inserted  
Normally locked  
(E1-E2 unpowered)

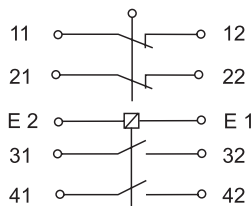

### JSNY8M

Key actuator inserted  
Normally unlocked  
(E1-E2 unpowered)

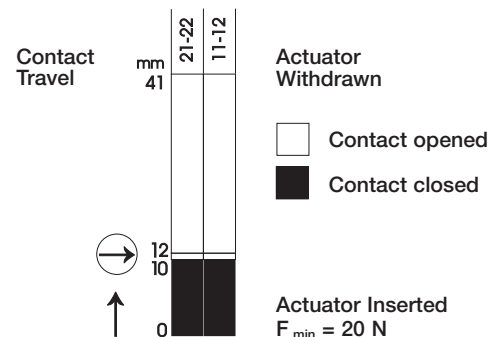

# JSNY9 Solenoid Locking Safety Interlock Switch

## Description

The JSNY9 is used for locking a gate/hatch, to prevent access to machinery, until hazardous operations have ceased.

Applications include:

- Processes which cannot be interrupted, e.g. welding.
- Machinery with a long stopping time, e.g. paper machinery which requires a long braking operation.
- Prevention of unauthorized access to a particular area.

The JSNY9 is equipped with a 2 x (1NO + 1 NC) contact configuration, the first pair of contacts changeover when the key is inserted. The second pair of contacts changeover when the locking mechanism is in the locked position.

The JSNY9 switch is encased in a robust plastic housing and can be mounted either horizontally or vertically. The advanced design of the head provides eight possible key insertion options. This is achieved by mounting the head either vertically or horizontally on the base unit, as shown in the diagram. The location for the actuator key is reinforced and beveled to ensure a smooth operation.

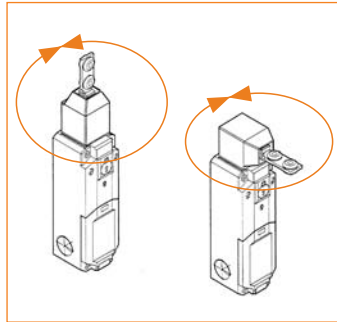

*The control unit offers eight operating positions that provide the actuator with eight different input options.*

## Two Versions

The JSNY9 switch is available in two basic versions, either with a spring lock or an electromagnetic locking mechanism.

The JSNY9S (spring lock) switch operates immediately when the gate/hatch is closed, i.e. when the key actuator is inserted into the locking mechanism. The gate/hatch can be opened and the actuator key released only by supplying the operational voltage to the solenoid connections (E1 E2). The JSNY9S also has a manual emergency "unlocking" facility to enable authorized release of the actuator key.

In the JSNY9M (magnetic lock) version, the mechanism is only locked when the gate/hatch is closed i.e. the actuator key inserted and the solenoid (E1 E2) supplied with the operating voltage. The gate/hatch can only be opened when this operating voltage is removed.

## Safety Level

In order to achieve a high safety level, the JSNY9 switch is equipped with dual sets of contacts operated with a coded actuator key. In order to meet the required installation safety level it is recommended that the JSNY9 safety switch is monitored by an appropriate ABB Jokab Safety safety relay, Pluto Safety PLC or Vital. To obtain the same level of safety as Knox, two switches per gate are required.



## Applications

- Gates and Hatches

## Features

- Compact and robust
- Universal installation
- 2 x (1 NO + 1 NC)
- Actuator holding force 1500 N
- Eight head configurations

## Protection from Unauthorized or Incidental Access

The JSNY9 is designed to protect against unauthorized access; screwdrivers, magnets or similar tools cannot manipulate the safety switch.

## Connection Examples

For examples of how our safety switches can solve various safety problems, see "Connection Examples" beginning on page 4:44 of the Safety Relay Section.

## Regulations and Standards

The JSNY9 is designed and approved in accordance with appropriate standards. See technical data.

## Approvals



# JSNY9S/M Technical Data

Manufacturer	ABB AB/Jokab Safety, Sweden
Ordering information	see page 8:32
Color	Black
Enclosure/Cover	Polyamid PA6
Actuator	Steel and plastic (PA6)
Min. key operating radius	400 mm
Actuator holding force	1500 N
Operating temperature	- 25° C to + 70° C
Contacts	
Actuator in	1 NO + 1 NC
Locking mechanism in locked position	1 NO + 1 NC (NC are direct opening action)
Mechanical life	1 million switch operations
Installation fixing	4 x M5
Cable entry	3 x M20 x 1.5
Weight	approx. 300 g
Enclosure class	IP67
Operating voltage	24 V AC/DC
Isolation voltage	250 V
Thermal current	2.5 A
Utilization category	AC 15 230V / 4A

Short-circuit protection	Fuse 6 A slow acting
Power consumption	1.1 VA (56 VA during 0.2s)
B <sub>10d</sub>	JSNY 9M: 2.00E+06 JSNY 9S: 2.00E+06
Conformity	2006/42/EG EN ISO 12100 1/2, EN 954-1, EN 60204-1, EN ISO 13849-1, EN 1088, GS-ET 19, EN 60947-5-1

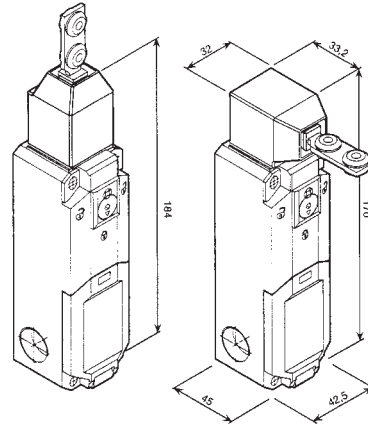

**Note:**  
The safety switch must not be used as an end stop!

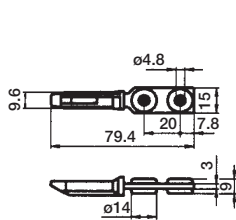

JSNY8/9N1

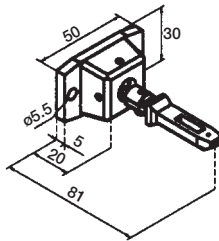

JSNY8/9N2  
Rmin: 150 mm

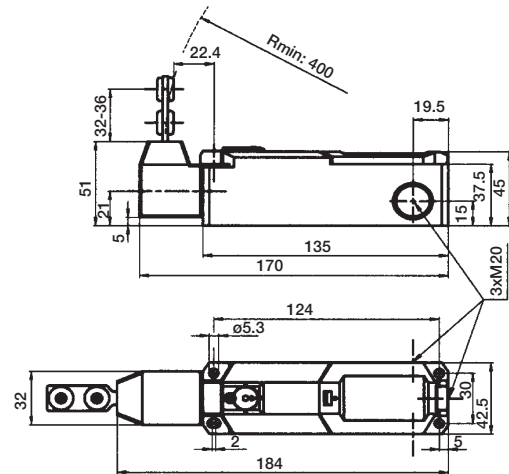

## JSNY9S/M Contact Description

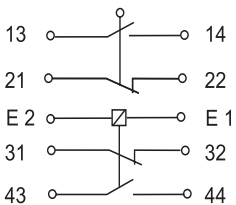

**JSNY9S**  
Actuator inserted  
Locked position  
(E1-E2 unpowered)

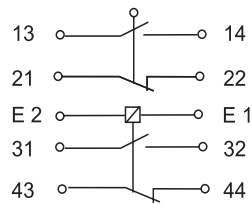

**JSNY9M**  
Actuator inserted  
Unlocked position  
(E1-E2 unpowered)

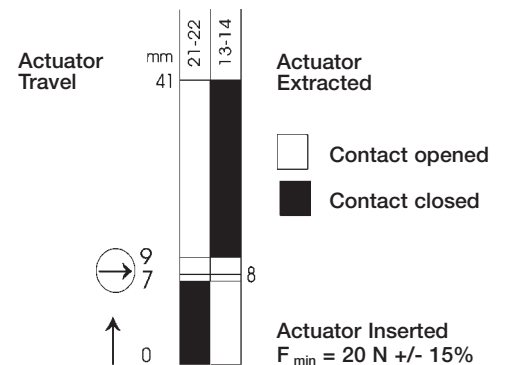

# Magne 1/2 Magnetic Process Lock with Indication

The Magne 1 is a magnetic lock which has been adapted for use in industrial applications and other harsh environments. It can electrically lock and hold a door closed with up to 1500 Newtons of force and when power is turned off no magnetic material will stick on the magnet surface.

Magne 1 can be used together with Eden door position sensors providing protection from dangerous machine movements.

Magne 2 already has an Eden sensor built in. Use of M12 connectors makes it easy to connect several Magne units and Eden sensors in series enabling control and monitoring by either a Pluto Safety PLC, a Vital Safety Module or a Urax block (for use in AS-i applications). Via the connection cable it is also possible to obtain an indication signal informing if the Magne unit is locked or not.

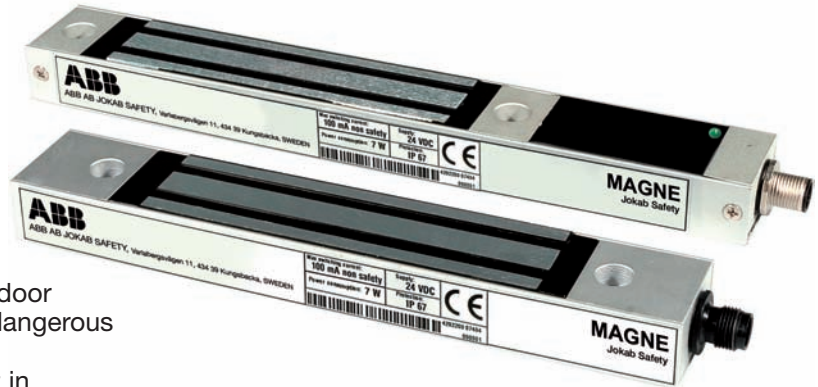

*Magne is easy to assemble, adjust and dismantle in and out of the T-slot of the Quick-Guard fencing system.*



## Applications

- Electrical locking of doors and hatches to production applications that are sensitive to unintentional/unnecessary interruptions
- For safety supervision the Magne 2 has an integrated Eden

## Features

- Robust construction
- No moving parts
- Strong magnetic holding force of 1500N
- Can stand and operate in harsh environments
- Locked/unlocked indication
- Possible to connect in series with Eden sensors
- No current peaks on activation
- Magne 2 in combination with a handle profile provides a complete door solution
- Magne 1/2 B versions come with a built-in 30mm magnet
- Magne 1/2 A/B X versions interface with the Urax block for AS-i applications

## Accessories

- Mounting kit for conventional door, with fitting and screws for assembly on ABB Jokab Safety Quick-Guard fencing system (5-15 mm door gap)
- Plastic handle
- Handle profile for mounting on a hinged door with Jokab Safety Quick-Guard fencing system (5-15 door gap)

## Magne Models and Accessories



Handle profile that hides Magne completely when the door is closed.

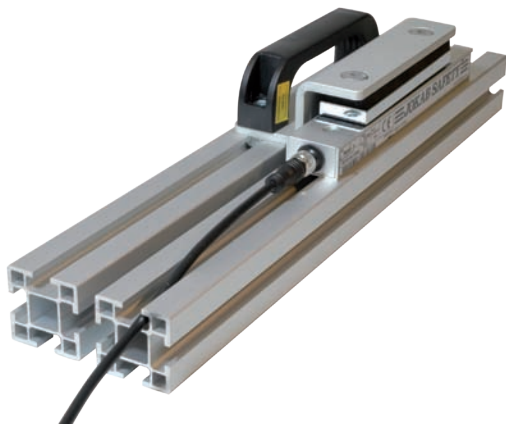

Magne 1A with installation kit (JSM D21B) and handle (incl. screw) fitted on profile.



Magne 2A with installation kit (JSM D21B) and sliding door fixture (JSM D23) fitted on profile.

<b>Magne 1A</b>	2TLJ042022R0000	Process lock, incl. anchor plate
<b>Magne 2A</b>	2TLJ042022R1000	Process lock with built-in Eden, incl. anchor plate
<b>Magne 1B</b>	2TLJ042022R0100	Process lock incl. anchor plate with built-in permanent magnet (30 N)
<b>Magne 2B</b>	2TLJ042022R1200	Process lock incl. anchor plate with built-in Eden and built-in permanent magnet (30 N)
<b>Magne 2Ax</b>	2TLJ042022R1300	Process lock with built-in Eden and 5-pin M12 connector for Urax, incl. anchor plate
<b>Magne 2Bx</b>	2TLJ042022R1400	Process lock with built-in Eden and 5-pin M12 connector for Urax, incl. anchor plate with built-in permanent magnet (30 N)
<b>Accessories</b>		
<b>JSM D21B</b>	2TLJ042023R0500	Assembly kit for anchor plate
<b>JSM D2AGS</b>	2TLJ042023R0100	Handle profile for Magne
<b>JSM D23</b>	2TLJ042023R0200	Fixture for sliding door
<b>JSM D24</b>	2TLJ042023R0300	Assembly kit for Eva
	2TLJ042023R0400	Anchor plate with permanent magnet
	2TLJ042023R1000	Handle for JSM D21B

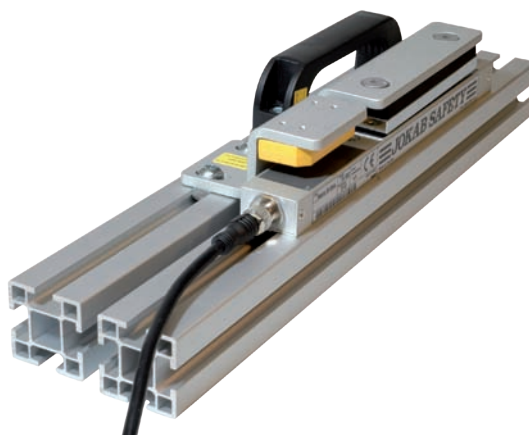

Magne 2A with installation kit (JSM D21B, JSM D24) and handle (incl. screw) fitted on profile.

## Magne Technical Data

<b>Manufacturer</b>	ABB AB/Jokab Safety, Sweden
<b>Ordering information</b>	see page 8:33
<b>Safety level</b> IEC/EN 61508-1...7 EN 62061 EN ISO 13849-1	SIL3 SIL3 Cat. 4/PL e
<b>PFH<sub>d</sub></b>	4.50×10 <sup>-9</sup>
<b>Power supply</b> Magnet Eden	24 VDC + 15% -20% 17–27 VDC, ripple max 10%
<b>Power consumption</b> Magnet Eden	7 W (300 mA at 24VDC) 45–55 mA (see data for Eden)
<b>Operating temp. range</b>	-20°C to +50°C
<b>Protection class</b>	IP67
<b>Weight</b> Magne 1 Magne 2 Anchor	610 g 700 g 290 g
<b>Material</b> Anchor plate and magnet Housing	steel aluminum
<b>Holding force</b> 24 VDC 0 VDC 0 VDC	Min 1500 N 0 N (Magne 1A/2A) 30 N (Magne 1B/2B)
<b>Contacts</b>	Reed sensor (not safe)
<b>Switch current max</b>	100 mA
<b>Mechanical life</b>	>10 <sup>7</sup> switch operations
<b>Connector</b>	M12 5-pole male connector (Magne 1A, 1B, 2Ax, 2Bx) M12 8-pole male connector (Magne 2A, 2B)

<b>Connections</b>	<p>Magne 1A/B: (1) Brown: Locking, +24 VDC (2) White: Sensor supply (3) Blue: 0 VDC (4) Black: NO-contact (5) Grey: NC-contact</p> <p>Magne 2A/B: (1) White: Dynamic signal input (2) Brown: +24V DC (3) Green: Locking, +24V DC (4) Yellow: Locking, 0V DC (5) Grey: Info closed (max 10 mA) (6) Pink: Dynamic signal output (7) Blue: 0V DC (8) Red: Info locked (max 100 mA)</p> <p>Magne 2Ax/Bx: (1) Brown: +24 VDC (2) White: Dynamic signal input (3) Blue: 0 VDC (4) Black: Dynamic signal output (5) Grey: Locking</p>
<b>Conformity</b>	2006/42/EG EN ISO 12100-1/2:2003, EN ISO 13849-1:2008, EN 62061:2005, EN 1088
<b>Certifications</b>	TÜV Nord 

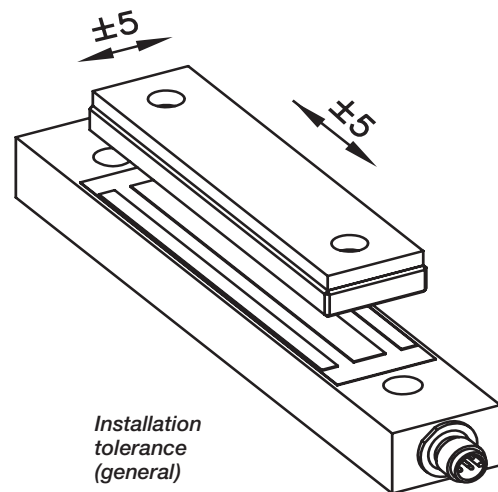

## Magne Dimensions

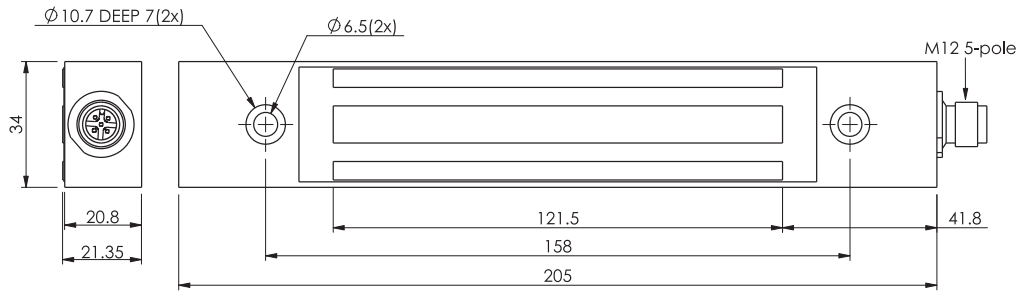

**Dimensions Magne 1A/B**

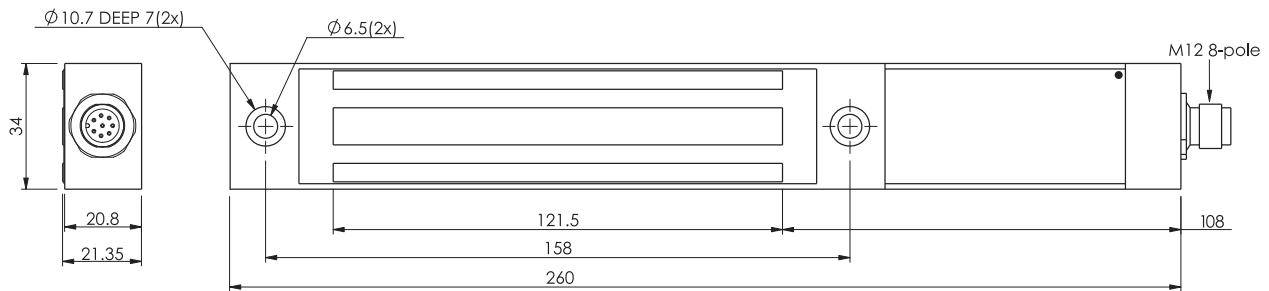

**Dimensions Magne 2A/B**

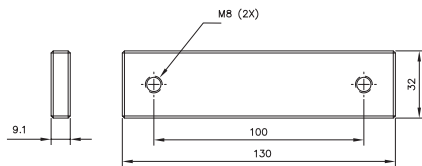

**Dimensions Anchor plate  
(without permanent magnet)**

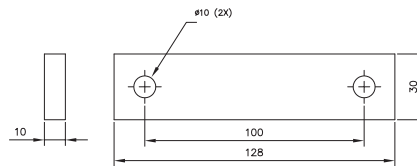

**Dimensions - cell rubber**

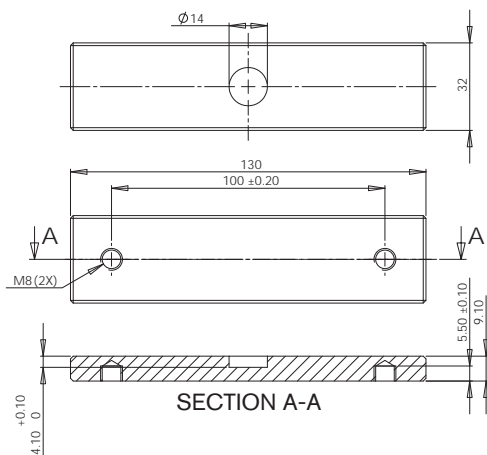

**Dimensions Anchor plate  
(with permanent magnet)**

# Holding Force

## Magne 1A/2A

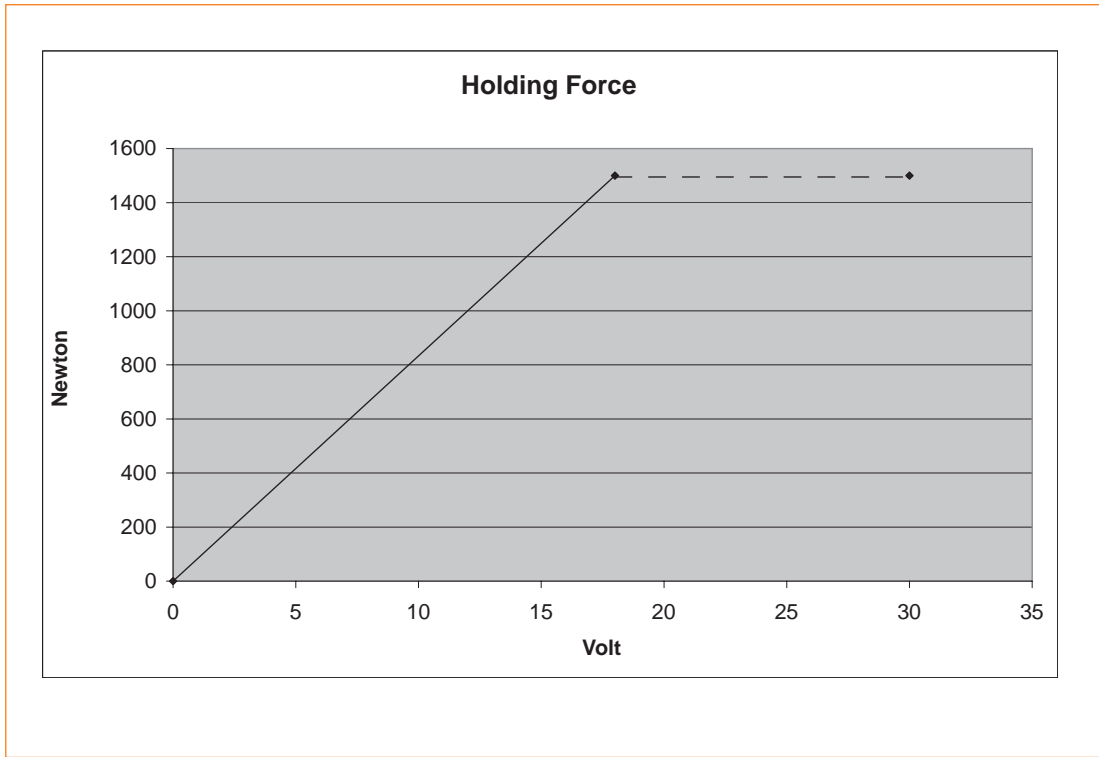

# Connection Example

## Magne 1/2

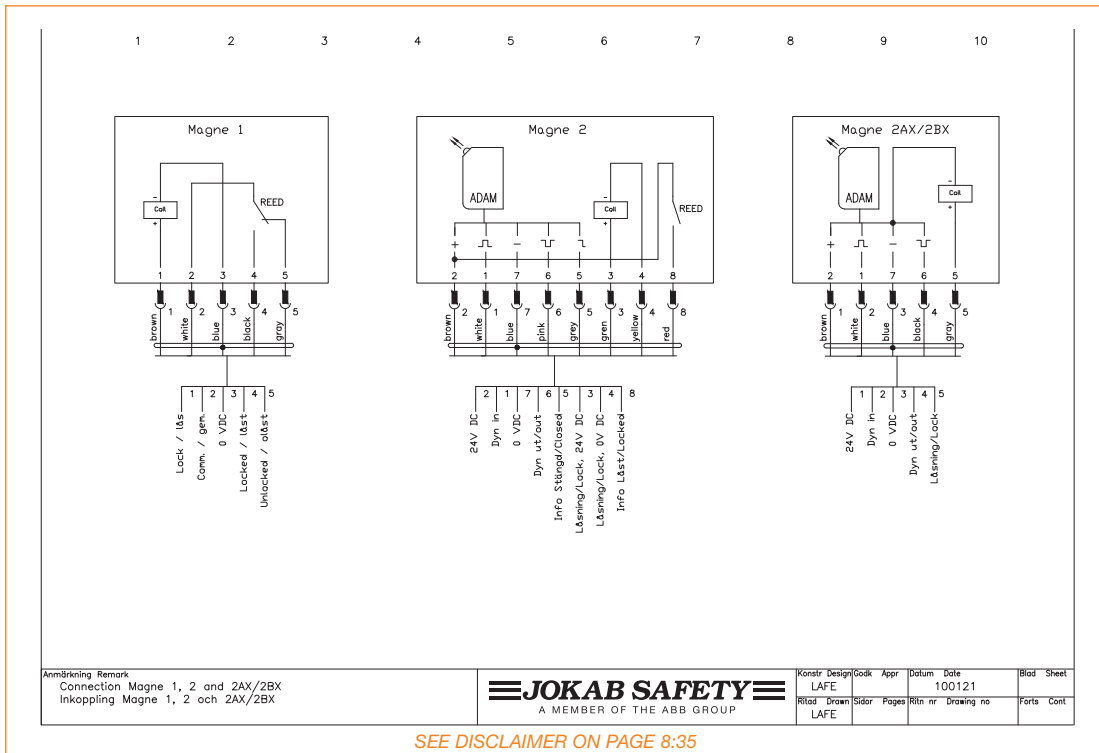

## Connection Example Magne 1A in series

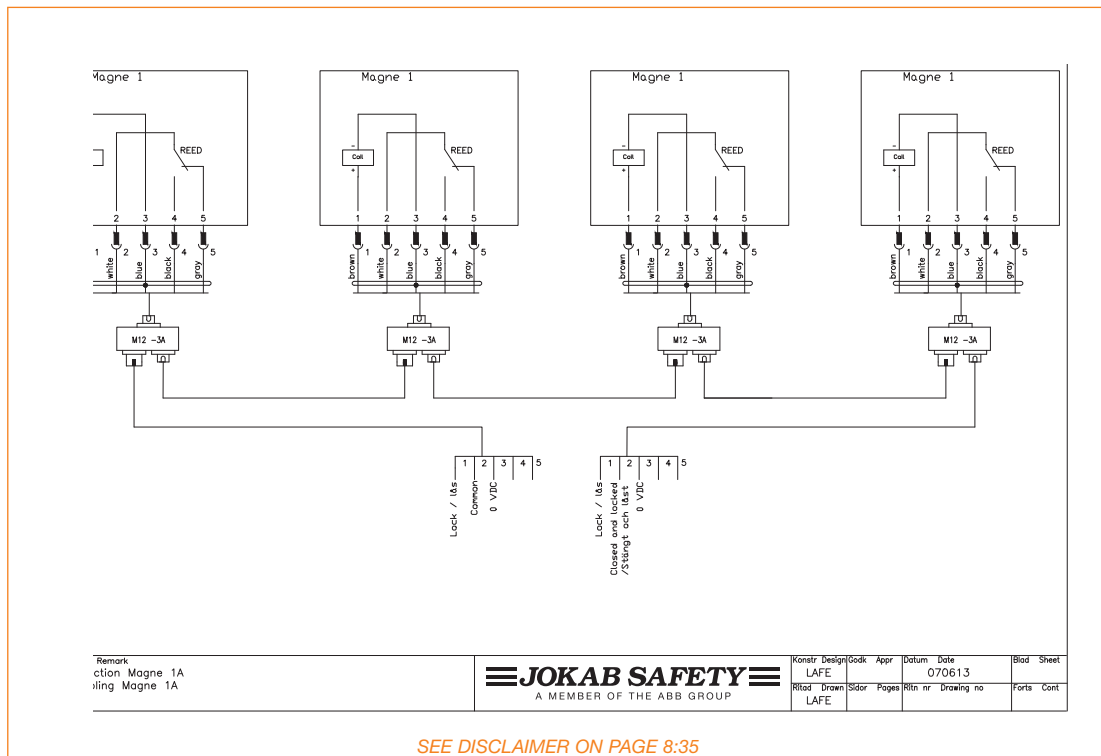

## Connection Example Magne 2A in series

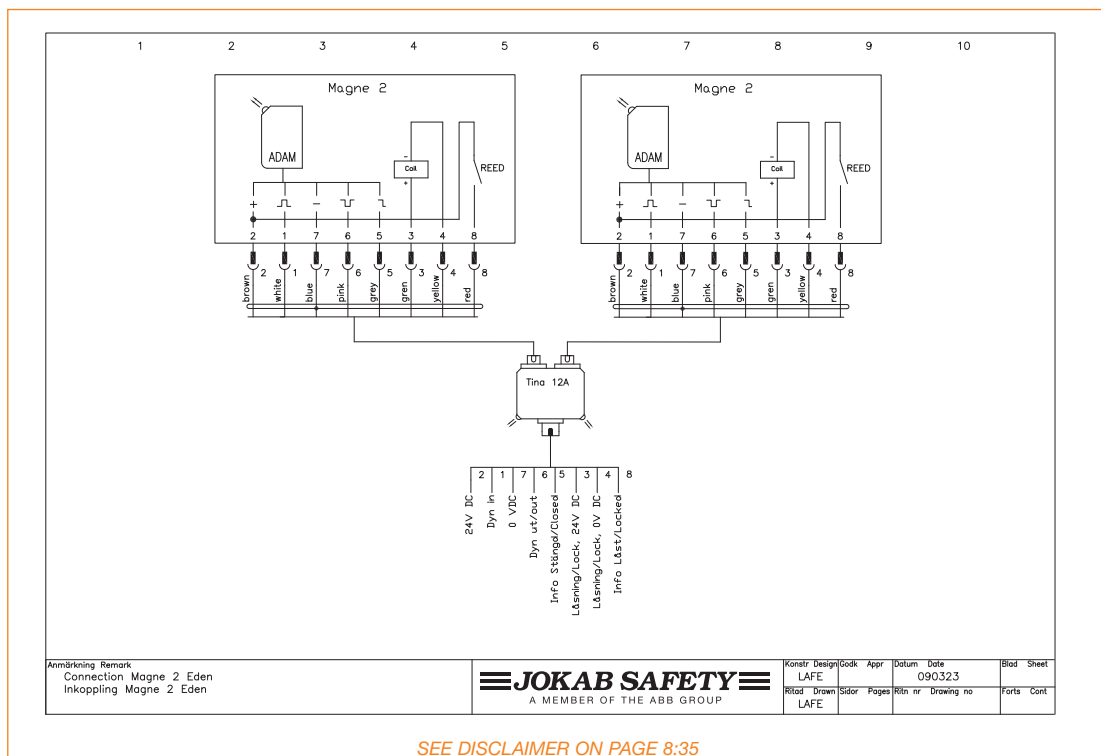

# Knox Safety Lock for Secure Locking

Knox is a double lock that complies with the highest safety level — two lock cylinders with monitored positions — that can be used both as a safety and process lock. The locking function is electronically controlled and is bi-stable, i.e. it retains its position (locked/unlocked) in the event of a power failure.

The handles operate as they would on a normal door — except that the exterior handle also has a reset function and there is an interior handle that can be used for emergency opening.

Its design and durability mean that it is ideal for harsh environments, as the sensors in the lock are non-contact and the lock is manufactured of stainless steel.

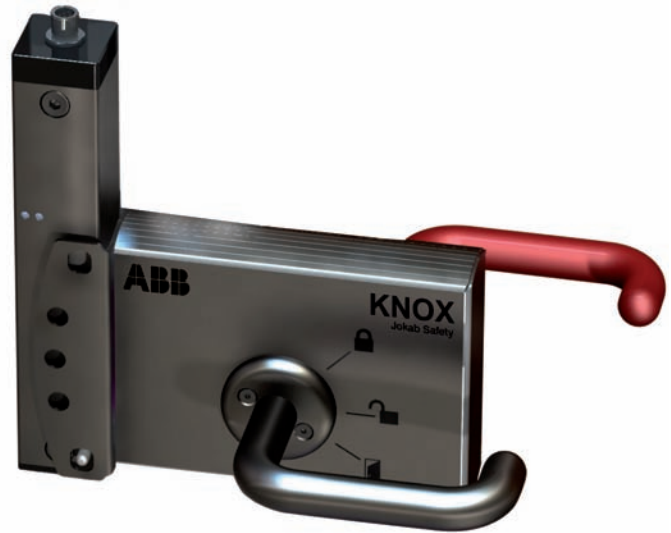

*Knox Safety Lock Open*



*Knox Safety Lock Emergency Opened*



*Knox Safety Lock Reset, Openable*



*Knox Safety Lock Operational Mode Locked and Reset (Emergency Opening Only)*

## Applications

- Locking doors to cells/lines with long stop times
- Application where you need a robust lock



## Features











- Double locking function as specified in PL e/Category 4 (EN ISO 13849-1)
- Withstands harsh environments
- Status information with LEDs on lock housing and at cable connection
- Controlled to locked and unlocked positions—remain locked/unlocked in the event of power failure
- Electronic connection only on the door frame
- Optional manual unlock from the outside available

## Approvals



# Knox Technical Data

<b>Manufacturer</b>	ABB AB/Jokab Safety, Sweden	
<b>Ordering information</b>	see page 8:34-8:35	
<b>Safety level</b> EN ISO 13849-1	Cat. 4/PL e	
<b>PFH<sub>d</sub></b>	4.50×10 <sup>-9</sup>	
<b>Lock function</b>	S/M - unlocked and locked with voltage	
<b>Operating voltage</b>	24 VDC +/- 15%	
<b>Power consumption</b>	70 mA (in locked position)	
Electronics	135 mA (when locking/unlocking)	
Lock/lock inverse	150 mA	
Total max	Max. 10 mA	
Information output		
<b>Insulation class</b>	IP65	
<b>Holding strength</b>		
Unlocked	5000 N (10,000 N ultimate breaking strength)	
Locked	5000 N (10,000 N ultimate breaking strength)	
<b>Connection</b>	Male plug M12, 8-pole	
<b>Connections Knox 2A</b>		
Function	8-pole	Color
Dynamic input signal	1	(White)
+24 VDC	2	(Brown)
Lock	3	(Green)
Lock inverse	4	(Yellow)
Information Locked	5	(Grey)
Dynamic output signal	6	(Pink)
0 VDC	7	(Blue)
Information reset	8	(Red)
<b>Connections Knox 2X</b>		
Function	5-pole	Color
+24 VDC	1	(Brown)
Dynamic signal input	2	(White)
0 VDC	3	(Blue)
Dynamic signal output	4	(Black)
Lock	5	(Grey)
<b>Warning</b>		
Knox locks mechanically. Forcing the lock may damage Knox permanently		
When mounting Knox on door with mesh the accessory PC plate for Knox is recommended. This is to prevent emergency opening from the outside		
When mounting Knox on a low door it is recommended to replace emergency release handle with the accessory PC plate for Knox to prevent opening from the outside by reaching over		
<b>Conformity</b>	2006/42/EG EN ISO 12100-1/2:2003, EN ISO 13849-1:2008, EN 62061:2005, EN 1088	
<b>Approvals</b>	 	

<b>LED indicator</b>	 =Red  =Green  =Pause	Function
<b>LED 1</b>	  	Locked (and reset) Locked, no dynamic signal in Unlocked
<b>LED 2</b>	 	Reset Not reset
<b>Alarm LED 2</b>	 	Dirt indicator reset sensor Reset Not reset

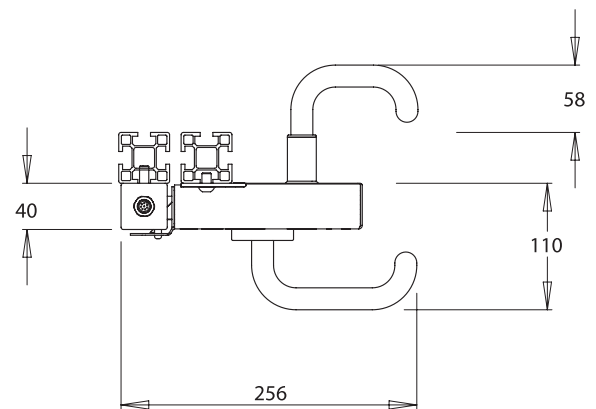
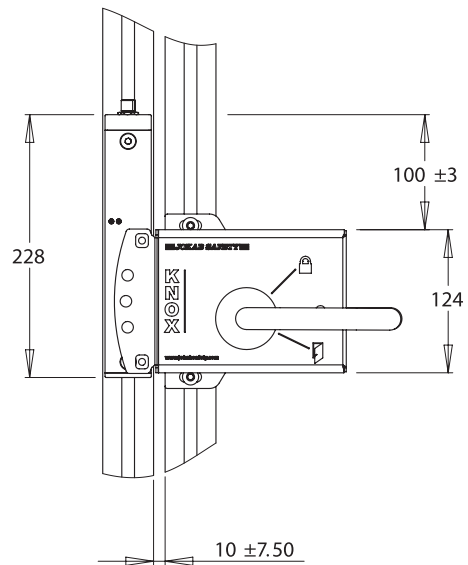

# Connection Example

## Knox

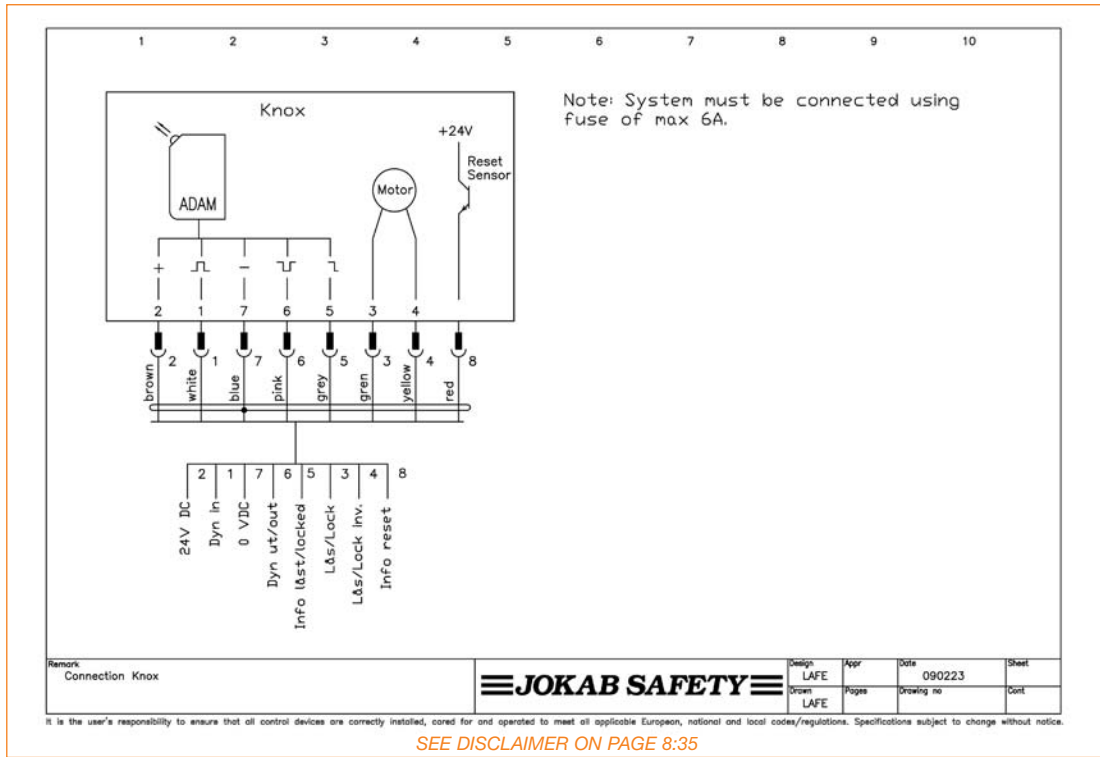

# Connection Example

## Knox and Pluto

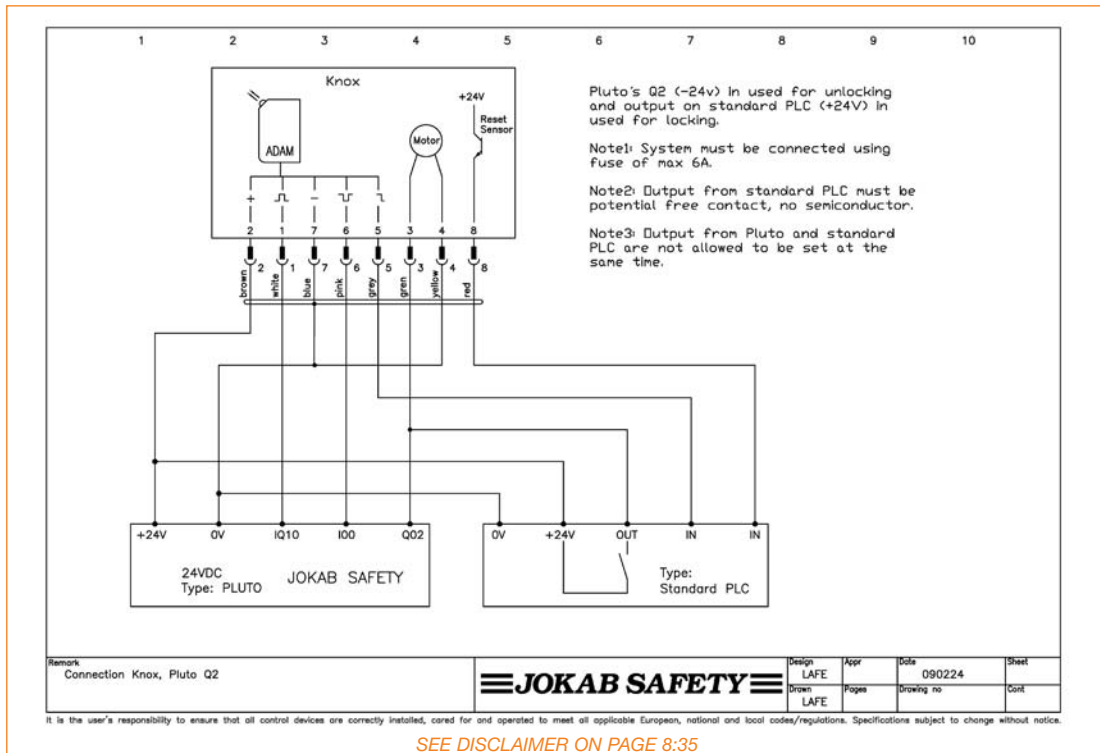



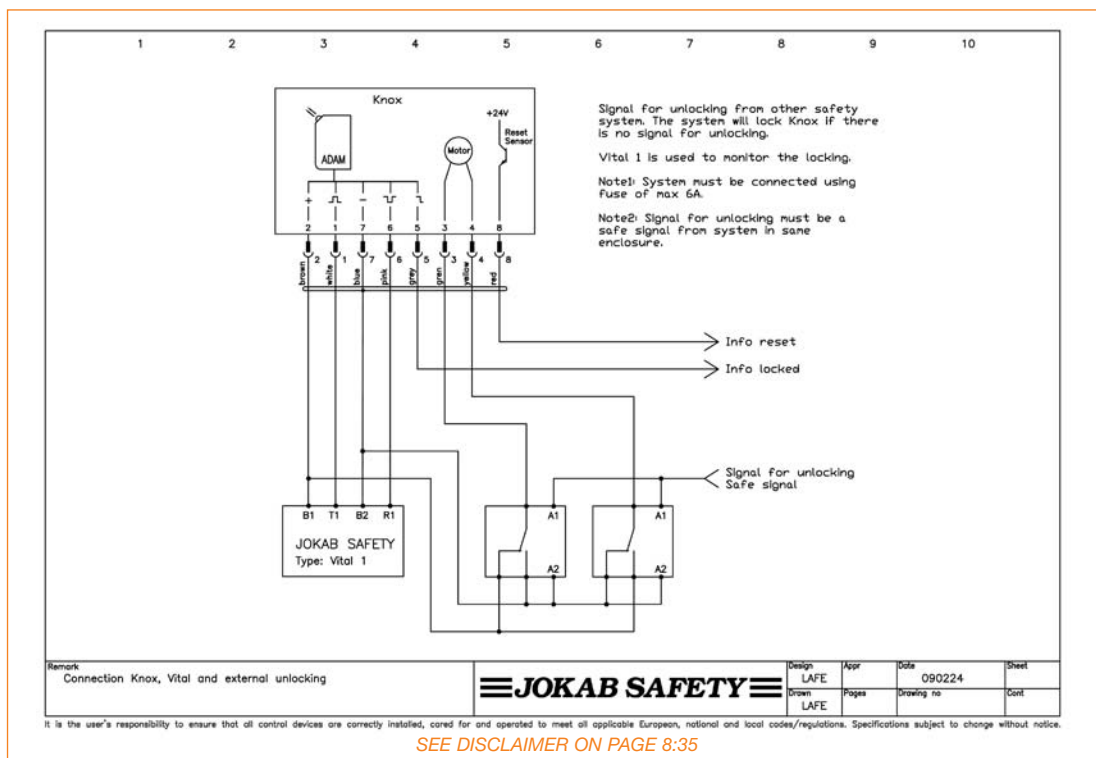

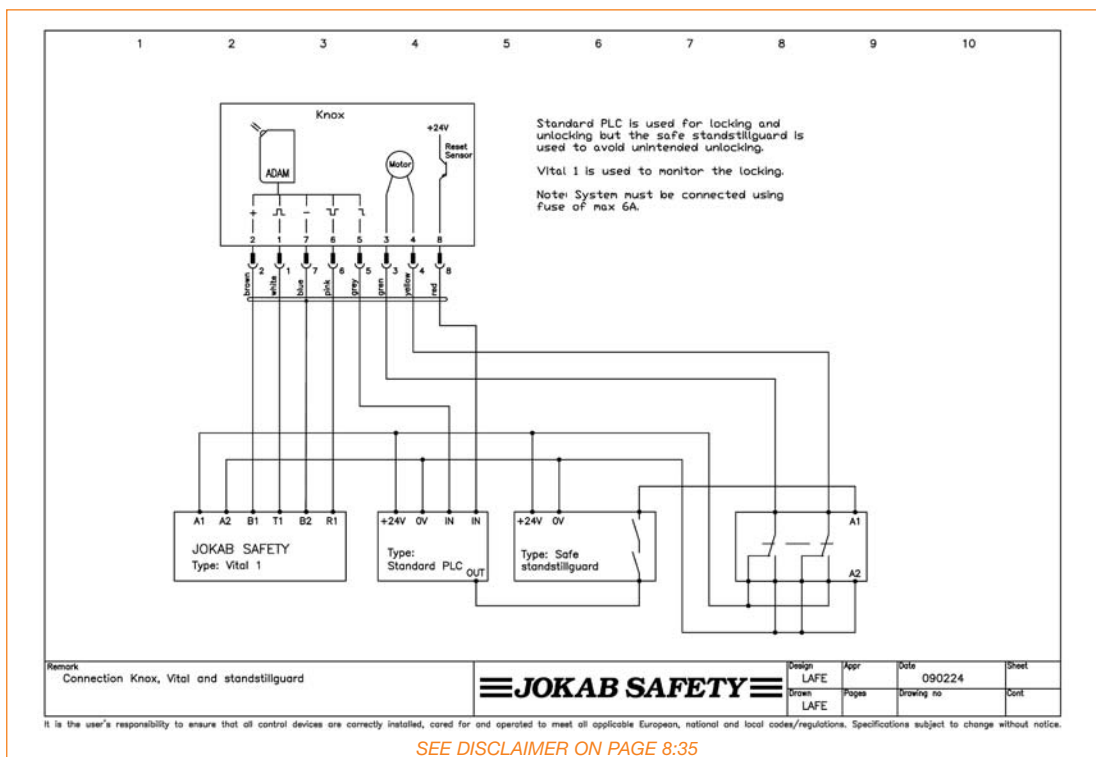

## Connection Example Knox with Vital and External Unlocking









## Connection Example Knox with Downtime Monitor



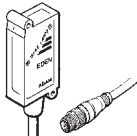

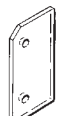

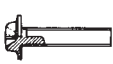
## Component List - Sensors and Switches

Designation	Ordering Information	Description
Eva	 2TLJ020046R0000	Electronic actuator for Adam switches, IP67 protection degree, polyamid housing. Includes 4 pieces of DA2 mounting washers.
Eva E	 2TLJ020046R0600	Electronic actuator encapsulated for Adam switches, IP69K protection degree, polyamid housing.
Adam M12	 2TLJ020051R0000	Non-contact electronic safety sensor with 5 pole M12 male quick disconnect, multi-function status indicator LED, integrated information output 24VDC - 10mA, IP67 protection degree, versatile mounting with 360 degree detection, sensing distance of 0-15mm +/- 2mm with Eva, polyamid housing. Requires Vital 1 controller or Pluto Safety PLC to function. Maximum of 30 Eden sensors connected to one Vital controller possible while maintaining category 4 level of safety (10 per Pluto input). 4 pieces DA1 distance protection plate and 4 pieces DA2 mounting washers included.
Adam 3m	 2TLJ020051R0200	Non-contact electronic safety sensor with 3 meter molded PVC cable, multi-function status indicator LED, integrated information output 24VDC - 10mA, IP67 protection degree, versatile mounting with 360 degree detection, sensing distance of 0-15mm +/- 2mm with Eva, polyamid housing. Requires Vital 1 controller or Pluto Safety PLC to function. Maximum of 30 Eden sensors connected to one Vital controller possible while maintaining category 4 level of safety (10 per Pluto input). 4 pieces DA1 distance protection plate and 4 pieces DA2 mounting washers included. M12 male connection at end of cable.
Adam 10m	 2TLJ020051R0400	Non-contact electronic safety sensor with 10 meter molded PVC cable, multi-function status indicator LED, integrated information output 24VDC - 10mA, IP67 protection degree, versatile mounting with 360 degree detection, sensing distance of 0-15mm +/- 2mm with Eva, polyamid housing. Requires Vital 1 controller or Pluto Safety PLC to function. Maximum of 30 Eden sensors connected to one Vital controller possible while maintaining category 4 level of safety (10 per Pluto input). 4 pieces DA1 distance protection plate and 4 pieces DA2 mounting washers included. M12 male connection at end of cable.
Adam 20m	 2TLJ020051R0500	Non-contact electronic safety sensor with 20 meter molded PVC cable, multi-function status indicator LED, integrated information output 24VDC - 10mA, IP67 protection degree, versatile mounting with 360 degree detection, sensing distance of 0-15mm +/- 2mm with Eva, polyamid housing. Requires Vital 1 controller or Pluto Safety PLC to function. Maximum of 30 Eden sensors connected to one Vital controller possible while maintaining category 4 level of safety (10 per Pluto input). 4 pieces DA1 distance protection plate and 4 pieces DA2 mounting washers included. M12 male connection at end of cable.

## Component List - Sensors and Switches

Designation		Ordering Information	Description
Adam E 10m		2TLJ020051R0600	Non-contact electronic safety sensor encapsulated with 10 meter molded PVC cable, multi-function status indicator LED, integrated information output 24VDC - 10mA, IP69K protection degree, versatile mounting with 360 degree detection, sensing distance of 0-12mm +/- 2mm with EvaE, polyurethane housing for harsh environments. Requires Vital 1 controller or Pluto Safety PLC to function. Maximum of 30 Eden sensors connected to one Vital controller possible while maintaining category 4 level of safety (10 per Pluto input). M12 male connection at end of cable.
Adam E 0.5m M12		2TLJ020051R0700	Non-contact electronic safety sensor encapsulated with 0.5 meter molded PVC cable and 5 pole M12 male quick disconnect, multi-function status indicator LED, integrated information output 24VDC - 10mA, IP69K protection degree (IP67 at connector), versatile mounting with 360 degree detection, sensing distance of 0-12mm +/- 2mm with EvaE, polyurethane housing for harsh environments. Requires Vital 1 controller or Pluto Safety PLC to function. Maximum of 30 Eden sensors connected to one Vital controller possible while maintaining category 4 level of safety (10 per Pluto input).
Adam E 20m		2TLJ020051R0800	Non-contact electronic safety sensor encapsulated with 20 meter molded PVC cable, multi-function status indicator LED, integrated information output 24VDC - 10mA, IP69K protection degree, versatile mounting with 360 degree detection, sensing distance of 0-12mm +/- 2mm with EvaE, polyurethane housing for harsh environments. Requires Vital 1 controller or Pluto Safety PLC to function. Maximum of 30 Eden sensors connected to one Vital controller possible while maintaining category 4 level of safety (10 per Pluto input).
DA 1		2TLJ020053R0000	Distance protective plate for Adam M12. Polycarbonate with 2.5mm thickness. Suitable for Adam 3m/10m/20m if necessary.
DA 2		2TLJ020053R0100	Mounting spacer 4.5 x 8 x 4 mm, polyamid for use with Adam and Eva units.
		2TLJ020053R1000	M4 mounting screw (length 18 mm) for recessed mounting of Adam and Eva.
		2TLJ020053R2000	M4 mounting screw (length 16 mm) for projecting mounting of Adam and Eva.
		2TLJ020053R3000	M4 mounting screw (length 25 mm) for projecting mounting of Adam E and Eva E.
		2TLJ020053R3200	M4 nylon mounting screw (length 25 mm) for recessed or projecting mounting of Adam and Eva ( Adam E and Eva E).

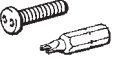
## Component List - Sensors and Switches

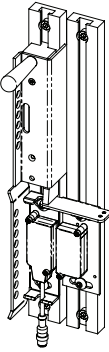
Designation	Ordering Information	Description
DA 2 (continued) 	2TLJ020053R4200	Safety screw (SM4 x 20) for mounting Adam and Eva.
	2TLJ020053R4300	Safety screw (SM4 x 25) for mounting of Adam E and Eva E.
	2TLJ020053R5000	Safety screwdriver bit SBITS
	2TLJ020053R6200	4 Safety screws (SM4 x 20mm) + 1 screwdriver bit
	2TLJ020053R6300	4 Safety screws (SM4 x 25mm) + 1 screwdriver bit
JSNA-SafeSlide™ 	2TLA850003R0800	Eden lockout assembly for safe lockout at the door. Provisions for up to 6 locks that fastens the metal plate between the Eden pair. Adjustable for either right side or left side opening doors.
JSNA-SafeSlide™ Sliding Doors	2TLA850103R0500	Eden lockout assembly for safe lockout at the door. Provisions for up to 6 locks that fastens the metal plate between the Eden pair. Designed for Quickguard sliding doors.

## Component List - Mechanical Switches

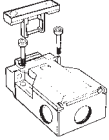
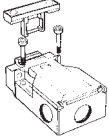
Designation	Ordering Information	Description
JSNY5A 	2TLJ020022R0000	Safety interlock switch with 2 NC positive opening & 1 NO contacts, 6A rated operational current, 10N actuator retention force, IP65, plastic body, two M20 conduit entries, comes with steel actuator.
JSNY5B 	2TLJ020022R0100	Safety interlock switch with 2 NC positive opening & 1 NO contacts, 6A rated operational current, 30N actuator retention force, IP65, plastic body, two M20 conduit entries, comes with steel actuator.







## Component List - Mechanical Switches

Designation	Ordering Information	Description
JSNY7R-3	2TLJ020023R0000	Magnetic safety switch with 1 NO & 1 NC contacts, 100mA switched current maximum, IP67, plastic body, 3 meters of molded cable.
JSNY7R-6	2TLJ020023R0100	Magnetic safety switch with 1 NO & 1 NC contacts, 100mA switched current maximum, IP67, plastic body, 6 meters of molded cable.
JSNY7R-10	2TLJ020023R0200	Magnetic safety switch with 1 NO & 1 NC contacts, 100mA switched current maximum, IP67, plastic body, 10 meters of molded cable.
JSNY7M	2TLJ020024R0000	Coded magnet for JSNY7 IP67, plastic body.
JSNY8M	2TLJ020030R0000	Safety interlock switch with power to lock 24VDC (5.2W) solenoid, 2 NC positive opening contacts from actuator and 2NC contacts from solenoid, 10A rated operating current, 1000N locking force, IP67, metal body, two M20 conduit entries, comes with metal actuator.
JSNY8S	2TLJ020030R0100	Safety interlock switch with power to unlock 24VDC (5.2W) solenoid, 2 NC positive opening contacts from actuator and 2NC contacts from solenoid, 10A rated operating current, 1000N locking force, IP67, metal body, two M20 conduit entries, comes with metal actuator.
JSNY8MN2	2TLJ020030R0200	Safety interlock switch with power to lock 24 VDC (5.2W) solenoid, 2 NC positive opening contacts from actuator and 2NC contacts from solenoid, 10A rated operating current, 1000 N locking force, IP67, metal body, two M20 conduit entries, comes with flexible actuator.
JSNY8SN2	2TLJ020030R0300	Safety interlock switch with power to unlock 24 VDC (5.2W) solenoid, 2 NC positive opening contacts from actuator and 2NC contacts from solenoid, 10A rated operating current, 1000 N locking force, IP67, metal body, two M20 conduit entries, comes with flexible actuator.

## Component List - Mechanical Switches

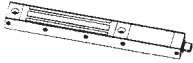
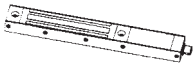
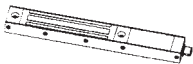
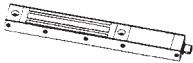
Designation	Ordering Information	Description
JSNYN1	2TLJ020032R0000	Steel actuator for JSNY4/5 safety interlock switches.
JSNYN2	2TLJ020032R0100	Steel actuator for JSNY4/5 safety interlock switches for horizontal operation.
JSNYN5	2TLJ020032R0600	Steel actuator for JSNY4/5 safety interlock switches with flexible bend.
JSNY8/9N1	2TLJ020032R0400	Steel actuator for JSNY8/9 safety interlock switches, standard.
JSNY8/9N2	2TLJ020032R0500	Steel actuator for JSNY8/9 safety interlock switches, flexible.
JSNY8EO	2TLJ020032R2000	JSNY8EO Emergency opening button for JSNY8S
JSNY9S	2TLJ020036R0100	Safety interlock switch with power to unlock 24VAC/DC (1.1VA) solenoid, 1 NO & 1 NC positive opening contacts from actuator and 1 NO & 1 NC positive opening contacts from solenoid, 10A thermal current, 1000N locking force, IP67, plastic body, three M20 conduit entries, comes with metal actuator.
JSNY9SN2	2TLJ020036R0200	Safety interlock switch with power to unlock 24VAC/DC (1.1VA) solenoid, 1 NO & 1 NC positive opening contacts from actuator and 1 NO & 1 NC positive opening contacts from solenoid, 10A thermal current, 1000N locking force, IP67, plastic body, three M20 conduit entries, comes with flexible actuator.
JSNY9M	2TLJ020036R2100	Safety interlock switch with power to lock 24VAC/DC (1.1VA) solenoid, 1 NO & 1 NC positive opening contacts from actuator and 1 NO & 1 NC positive opening contacts from solenoid, 10A thermal current, 1000N locking force, IP67, plastic body, three M20 conduit entries, comes with metal actuator.
JSNY9MN2	2TLJ020036R2200	Safety interlock switch with power to lock 24 VAC/DC (1.1VA) solenoid, 1 NO & 1 NC positive opening contacts from actuator and 1 NO & 1 NC positive opening contacts from solenoid, 10A thermal current, 1000 N locking force, IP67, plastic body, three M20 conduit entries, comes with flexible actuator.



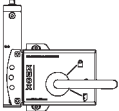
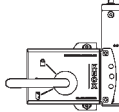
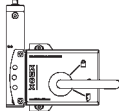
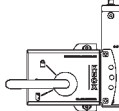
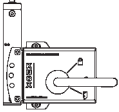
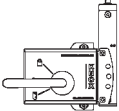
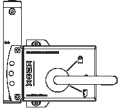
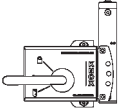
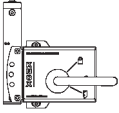
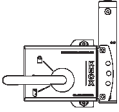

## Component List - Mechanical Switches

Designation	Ordering Information	Description
Magne 1A 	2TLJ042022R0000	Process lock, including anchor plate
Magne 1B 	2TLJ042022R0100	Process lock including anchor plate with built-in permanent
Magne 2A 	2TLJ042022R1000	Process lock with built-in Eden, including anchor plate.
Magne 2B 	2TLJ042022R1200	Process lock included. Anchor plate with built-in permanent magnet (30 N).
Magne 2Ax 	2TLJ042022R1300	Process lock with built-in Eden and 5-pin M12 connector for Urax, including anchor plate.
Magne 2Bx 	2TLJ042022R1400	Process lock with built-in Eden and 5-pin M12 connector for Urax, including anchor plate with built-in permanent magnet (30 N).
JSM D21B 	2TLJ042023R0500	Assembly kit for anchor plate.
JSMD2 	2TLJ042023R01000	Handle profile for JSM D21B.
JSM D23	2TLJ042023R0200	Fixture for sliding door.
JSM D24	2TLJ042023R0300	Assembly kit for Eva.
	2TLJ042023R0400	Anchor plate with permanent magnet.
JSMD2AGS 	2TLJ042023R0100	Magne protective handle mounting kit for use with Magne 1A and Magne 2A anchors and optional Evas on regular swing doors. Extruded aluminum profile completely hides the Magne unit when the door is closed. This handle can be used for both right and left doors as well as cable exit up or down.

## Component List - Mechanical Switches

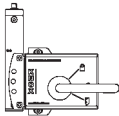
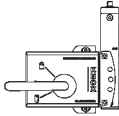
Designation	Ordering Information	Description
Knox 1A-R v2 	2TLJ020105R5000	Knox door part for outward-opening right-hung door.
Knox 1A-L v2 	2TLJ020105R5100	Knox door part for outward-opening left-hung door.
Knox 1B-R v2 	2TLJ020105R5200	Knox door part for inward-opening right-hung door.
Knox 1B-L v2 	2TLJ020105R5300	Knox door part for outward-opening left-hung door.
Knox 1AX-R v2 	2TLJ020105R5800	Knox door part for outward-opening right-hung door with the option for manual unlocking from the outside.
Knox 1AX-L v2 	2TLJ020105R5900	Knox door part for outward-opening left-hung door with the option for manual unlocking from the outside.
Knox 1F-R v2 	2TLJ020105R6000	Knox door part for sliding door that opens to the right. Including additional fastening fixtures for the frame.
Knox 1F-L v2 	2TLJ020105R6100	Knox door part for sliding door that opens to the left. Including additional fastening fixtures for the frame.
Knox 1BX-R v2 	2TLJ020105R6200	Knox door part for inward-opening right-hung door with the option for manual unlocking from the outside.
Knox 1BX-L v2 	2TLJ020105R6300	Knox door part for inward-opening left-hung door with the option for manual unlocking from the outside.

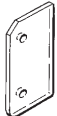
## Component List - Mechanical Switches

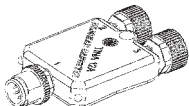
Designation	Ordering Information	Description
Knox 1FX-R v2 	2TLJ020105R6400	Knox door part for sliding door that opens to the right with the option for manual unlocking from the outside. Includes additional fastening fixtures for the frame.
Knox 1FX-L v2 	2TLJ020105R6500	Knox door part for sliding door that opens to the left with the option for manual unlocking from the outside. Includes additional fastening fixtures for the frame.
Knox 2A v2 	2TLJ020105R2200	Standard Knox frame part 8-pin M12 contact, supplied for right-hung door. For instructions for turning, see the Knox manual.
Knox 2X v2	2TLJ020105R2300	Knox process lock, no duplicate unlocking signal, with 5-pin M12 contact.
PC Plate for Knox on Mesh Door	2TLJ020106R0000	When mounting Knox on door with mesh the accessory PC plate for Knox is recommended. This is to avoid emergency opening from the outside.
Mounting Plate for Knox without Emergency Release	2TLJ020106R0600	When mounting Knox on a low door, it is recommended to replace emergency release handle to prevent opening from the outside by reaching over.
DA 1 	2TLJ020053R0000	Distance protective plate for Adam M12. Polycarbonate with 2.5mm thickness. Suitable for Adam 3m/10m/20m if necessary.
M12-CT0214 	2TLJ020060R0100	Extension cable 20cm, black PVC jacket with straight 5 pole M12 female, 8 pole M12 male connectors, 22AWG conductors, overall braid shield.
Tina 12A 	2TLJ020054R1800	Dynamic connection block, 2 ports for connecting up to 2 safety devices with dynamic signals and locking inputs. Ports are 8 pole M12 female quick disconnects. 8 pole M12 male quick disconnect for connecting the safety devices to the Vital 1 controller or Pluto Safety PLC. Multi-function status indicator LEDs, integrated information output 24VDC - 10mA.

This document and any attachments may include suggested specifications, drawings, schematics and similar materials from ABB Inc. Use of such information and/or documentation by the recipient is subject to and conditioned upon your acceptance of the terms of the General Document Disclaimer which can be found at [www.jokabsafety.com](http://www.jokabsafety.com). Your acceptance of the terms of such General Document Disclaimer is conclusively presumed unless you notify ABB in writing of your disagreement with the terms of such Disclaimer immediately upon receipt of this document and you return to ABB all specifications, drawings, schematics and similar materials provided to you by ABB.