

EasyHandling – more than just a kit of components

The system solution at a glance



The ideal system solution for the ideal application



**4 EasyHandling –
more than just a kit of components**

6 Applications

- 8 Key parameters for system design
 - 10 Pick & place
 - 12 Linear gantry
 - 14 X-Y table
 - 16 Cantilever gantry
 - 18 H-type gantry
-

20 Components

- 22 Highlights and options
- 24 Linear modules
- 28 Compact modules
- 30 Bridge modules
- 32 Precision modules
- 33 Ball rail tables
- 34 Mini slides
- 36 Feed modules
- 38 Rotary compact modules
- 39 Rotary indexing tables
- 40 Grippers
- 42 Pneumatic valves
- 43 Vacuum technology
- 44 Servo motors, linear motors
- 46 Compact electric drives
- 48 Compact controls
- 49 I/O technology
- 50 Visualization
- 51 Further components and systems

52 Engineering

- 54 Project planning
 - 55 Mounting
 - 56 Parameter input
 - 58 Programming
-

60 Services

- 62 Consulting
 - 64 Training
 - 66 Technical customer service
-

68 Further information

EasyHandling – more than just a kit of components

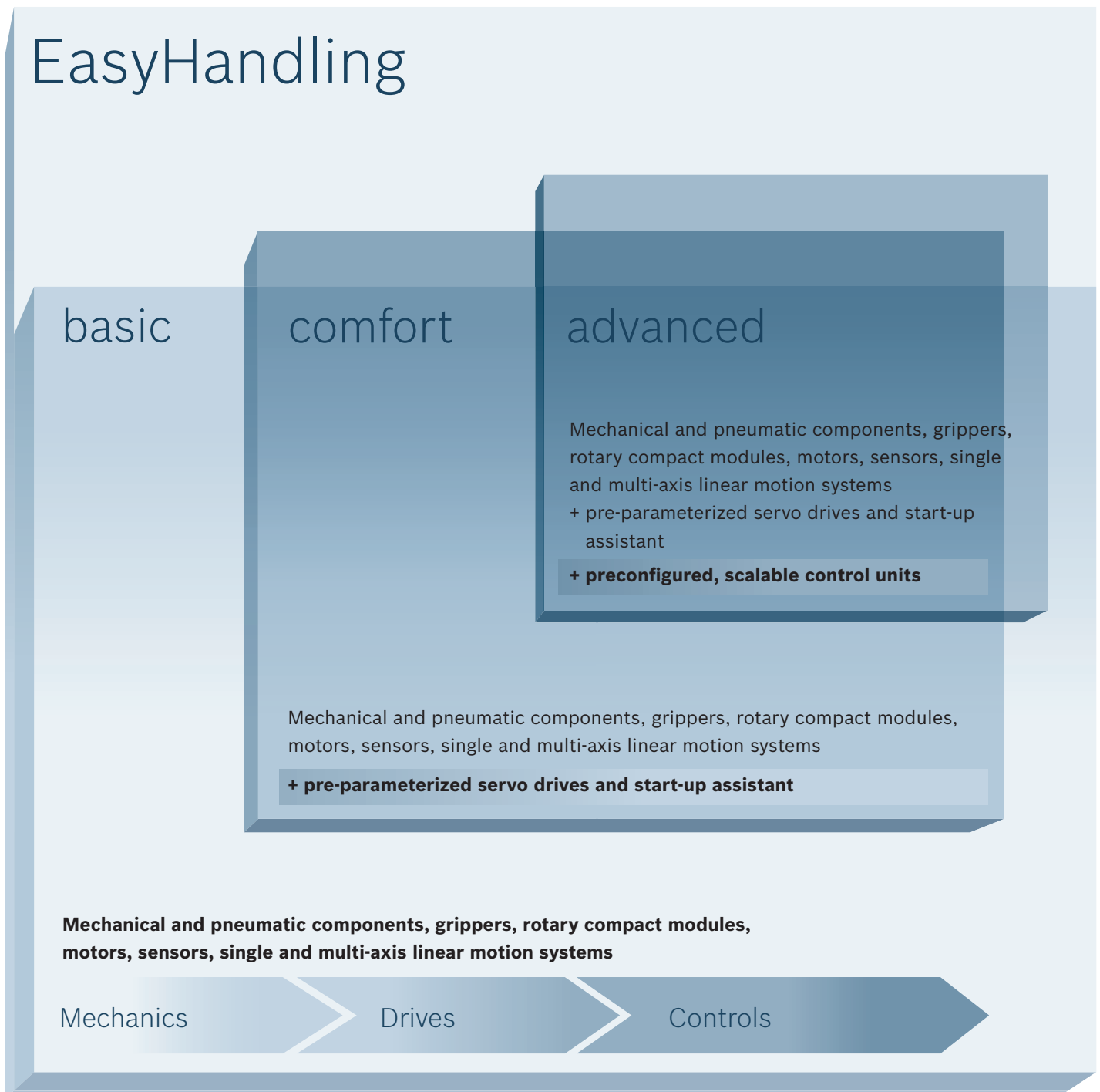

With EasyHandling, Rexroth is making the automation of handling systems significantly easier, faster and more economical. EasyHandling is more than just a modular collection of mechanical components – it takes an evolutionary step forward by providing all-inclusive building systems. Its drive and control technologies, standardized interfaces, and the novel start-up assistant are all precisely matched. The perfect interaction of all these elements reduces project planning, installation and start-up times by up to 80 percent.



basic – made-to-measure mechatronics

EasyHandling Basic includes single and multi-axis linear motion systems for all mechanical drive types. The modules are delivered complete with the matching motors or pneumatic drives. Grippers, rotary compact modules and sensors ideally complement the range.



comfort – getting started even faster

EasyHandling Comfort expands the Basic component range by adding pre-parameterized servo drives with multiple protocol capability. It also features the uniquely convenient start-up assistant EasyWizard, so that the system is ready to use after entering the data for just a few application-specific details.



advanced – for demanding requirements

With the scalable, preconfigured motion logic control system, EasyHandling Advanced makes configuration and handling even easier. Predefined functions covering more than 90 percent of all handling applications eliminate the need for lengthy programming.



Applications

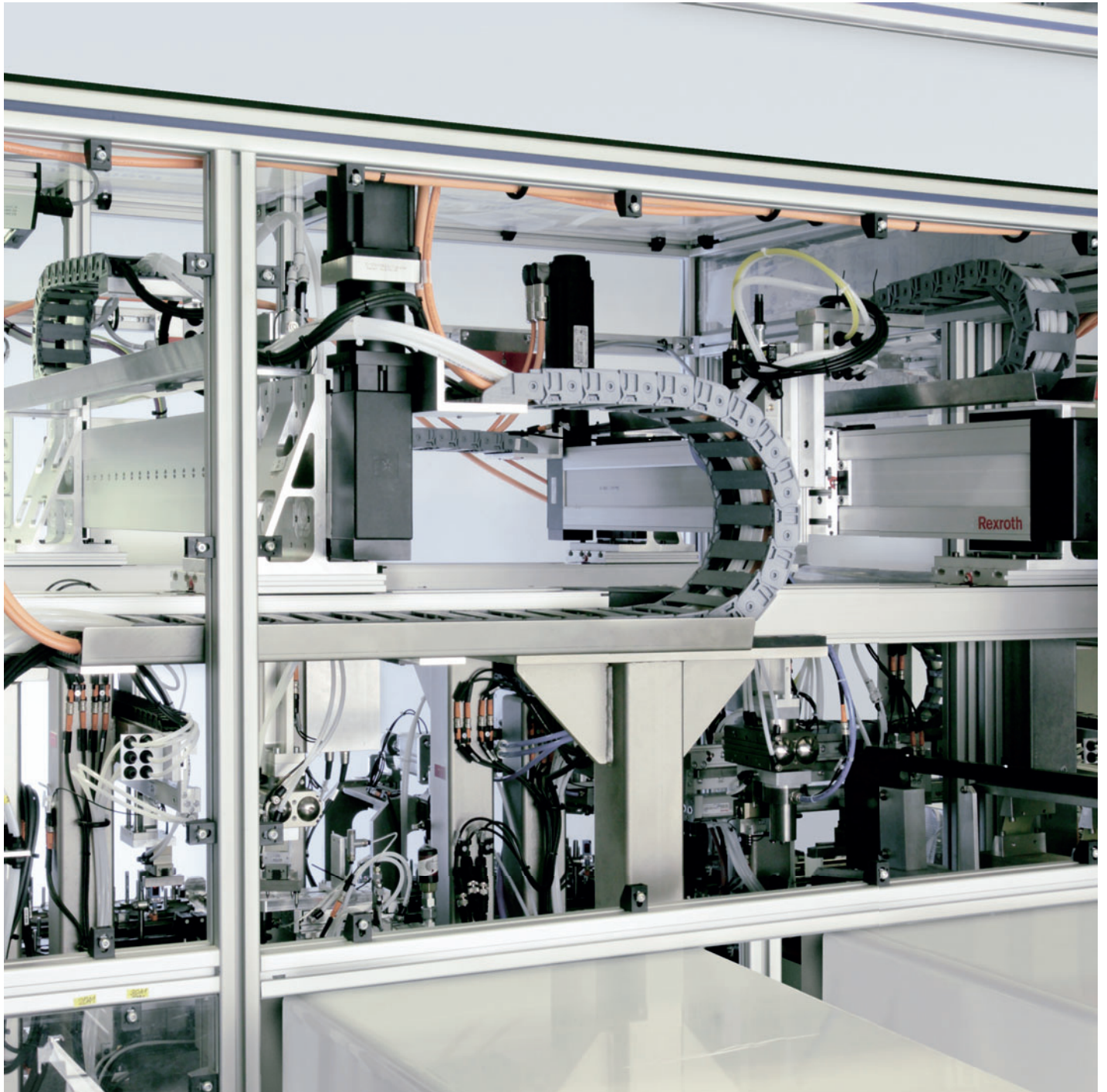

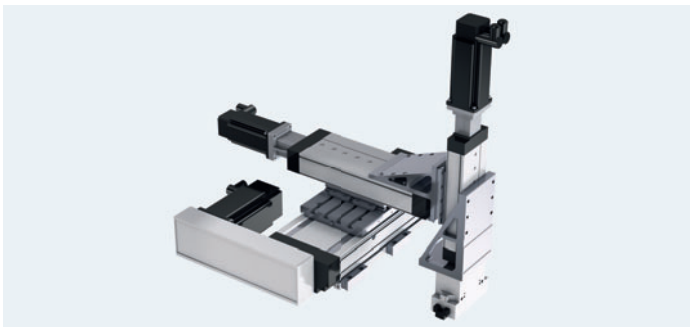
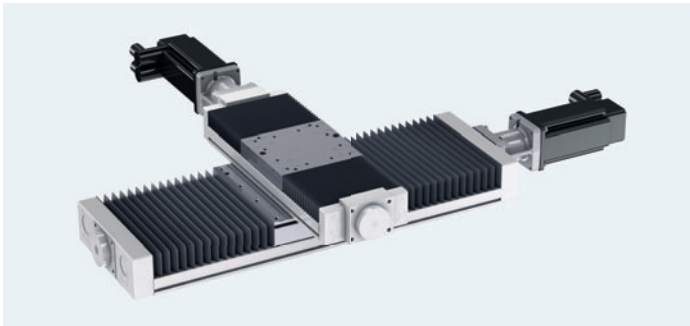

6 Applications

- 8 Key parameters for system design
- 10 Pick & place
- 12 Linear gantry
- 14 X-Y table
- 16 Cantilever gantry
- 18 H-type gantry

Key parameters for system design

To make sure your handling system delivers top performance, both technically and economically, the right decisions have to be made as early as the planning phase. There are five key parameters that have a decisive influence on the choice of system and its structural design:

- ▶ Geometry
- ▶ Load
- ▶ Dynamics
- ▶ System accuracy
- ▶ Environmental conditions

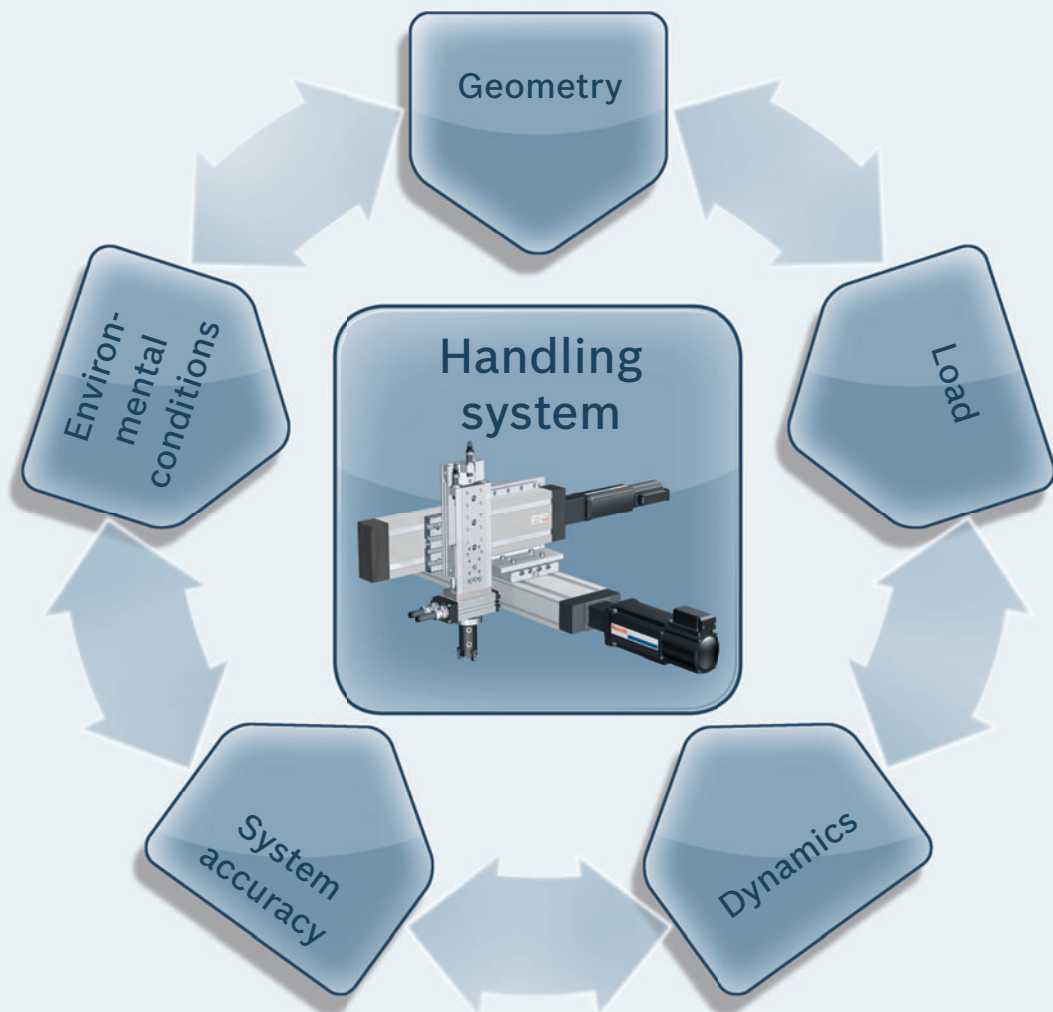

Geometry

- ▶ Work space
- ▶ Installation space
- ▶ Ergonomics
- ▶ Degrees of freedom
- ▶ Stroke length
- ▶ Obstructing contours
- ▶ etc.

Load

- ▶ Service life
- ▶ Moment loads
- ▶ Process force
- ▶ Load capacities
- ▶ Payload
- ▶ etc.

Dynamics

- ▶ Acceleration
- ▶ Travel speed
- ▶ Jerk
- ▶ Cycle time
- ▶ etc.

System accuracy

- ▶ Path accuracy
- ▶ Synchronism
- ▶ Positioning accuracy
- ▶ Rigidity
- ▶ Repeatability
- ▶ Compliance
- ▶ etc.

Environmental conditions

- ▶ EMC
- ▶ Humidity
- ▶ Material characteristics
- ▶ Contamination
- ▶ Temperature
- ▶ etc.

A linear system that matches your needs in just six steps

On the following pages you will find the five most common types of application in handling technology – pick & place, linear gantry, X-Y table, cantilever gantry, and H-type gantry.

The tables and charts will help you to identify the optimal Rexroth linear system for your application, while considering the key parameters of load, dynamics and accuracy in relation to the required stroke.

The procedure:

- 1 Define your application. → e.g. linear gantry
- 2 Define the key parameter that you will focus on most when implementing your application. → e.g. load
- 3 Define your requirements for stroke/length per axis, basing them on the work-piece to be handled. → e.g. Z-axis with a 1,000 mm stroke
- 4 Locate your stroke/length on the curve.
- 5 Draw an imaginary line vertically down from this point until you reach the key parameter section you have chosen.
- 6 The linear systems closest to this line on the left hand side are the most suitable ones for your application. They are arranged from top to bottom according to their respective load capacities.

1 Example for a linear gantry

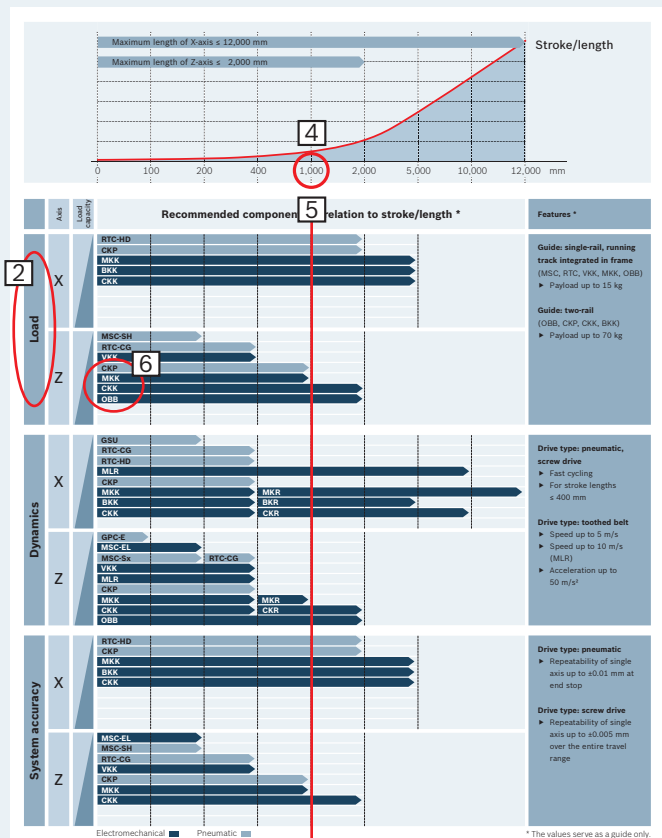

The products are listed here using their short names. You will find the corresponding product descriptions in the “Components” chapter.

Pick & place

Pick & place systems are multi-purpose electrically or pneumatically driven handling systems to accommodate grippers and tools. They have been specially developed for integration into automatic assembly lines. Generally, these are two-axis systems which perform X-Z movements and are used either to feed parts into a system or to transfer and position workpieces.

Application example for a pick & place system with the focus on

- ▶ Fast cycling
- ▶ Compact construction
- ▶ Small parts handling

Application areas

- ▶ Insertion and placement of parts
- ▶ Loading and unloading
- ▶ Re-positioning

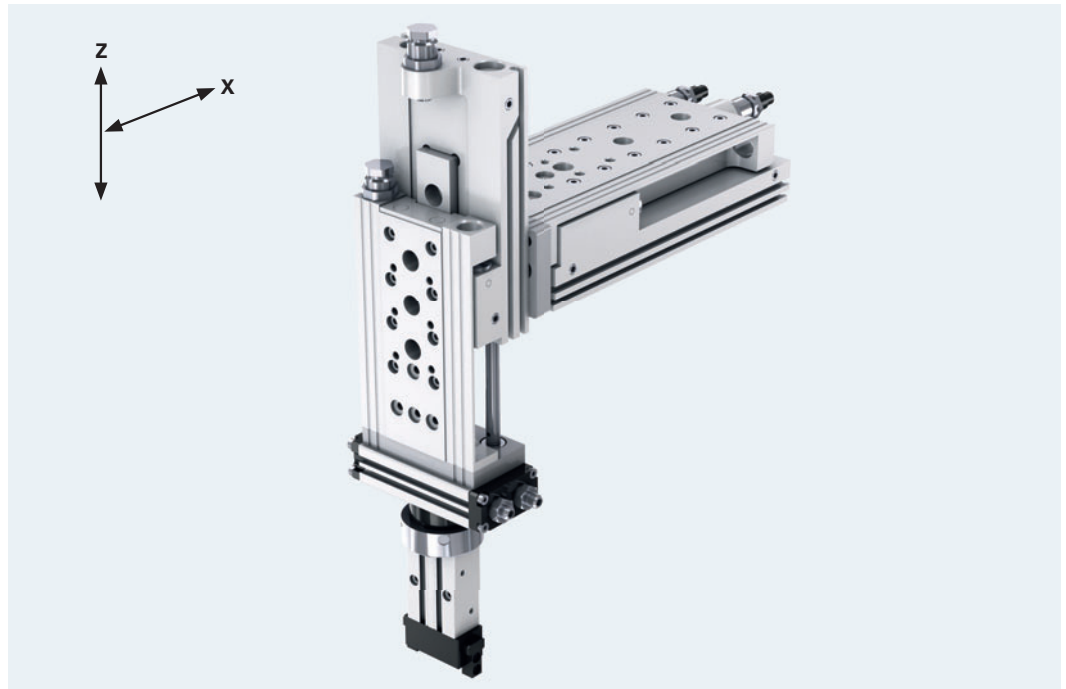

Application example for a pick & place system with the focus on

- ▶ High speeds
- ▶ Large work zone
- ▶ Bulky, difficult-to-handle workpieces
- ▶ Large-format workpieces
- ▶ Deep penetration into work zones

Application areas

- ▶ Insertion and placement of parts
- ▶ Loading and unloading
- ▶ Re-positioning

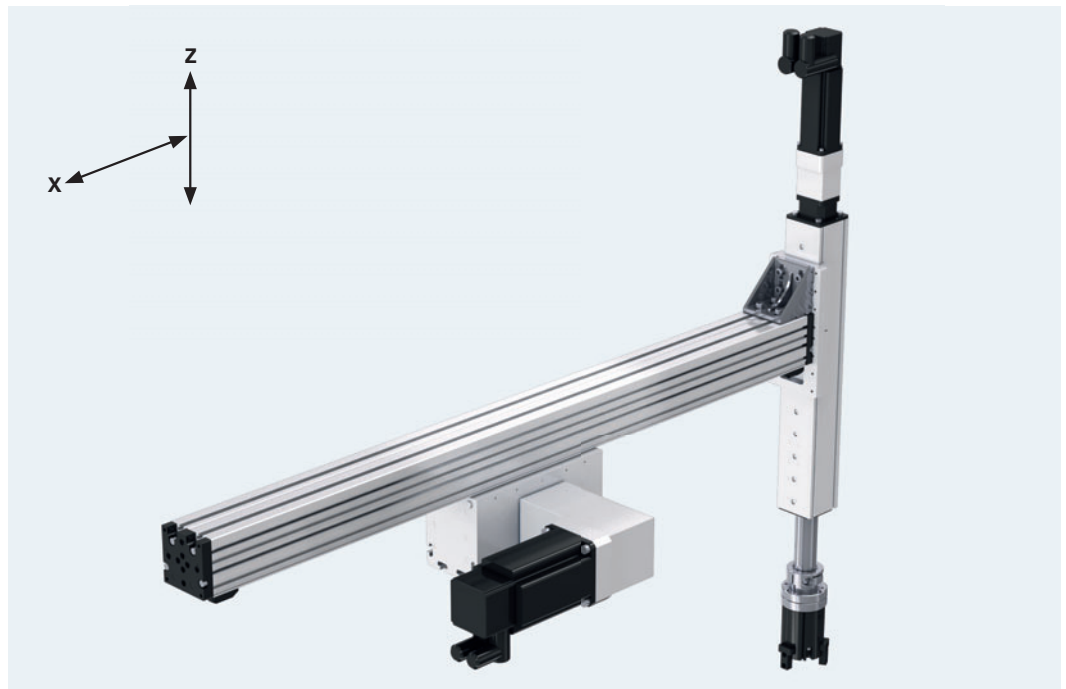

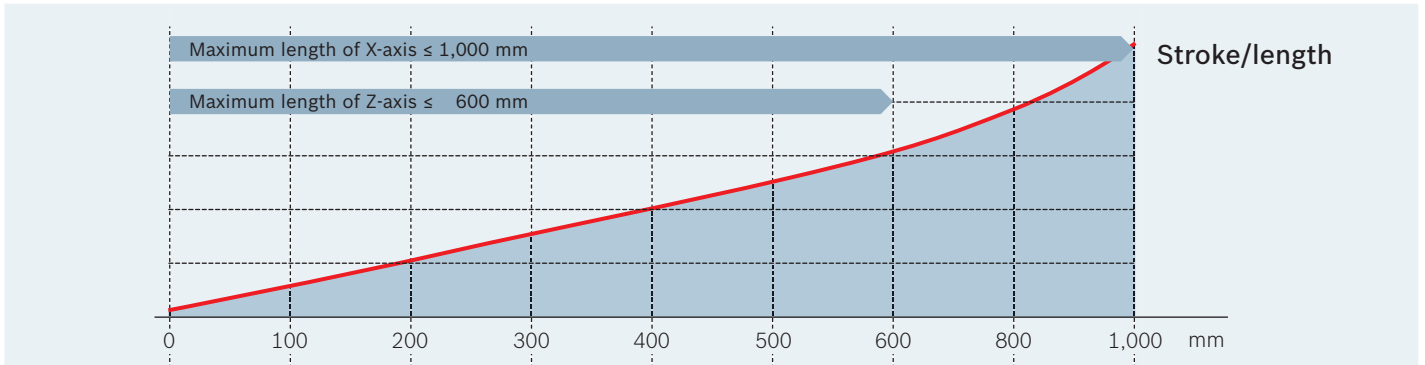

	Axis	Load capacity	Recommended components in relation to stroke/length *	Features *
Load	X		MSC-SH CKP CKK	Guide: single-rail, running track integrated in frame (MSC, VKK, OBB) ▶ Payload up to 10 kg Guide: two-rail (OBB, CKP, CKK) ▶ Payload up to 20 kg
	Z		MSC-SH VKK CKP CKK OBB	
Dynamics	X		GPC-E MSC-EL MSC-Sx OBB CKK CKR	Drive type: pneumatic, screw drive ▶ Fast cycling ▶ For stroke lengths ≤ 400 mm Drive type: toothed belt ▶ Speed up to 5 m/s ▶ Acceleration up to 50 m/s ²
	Z		GPC-E MSC-EL MSC-Sx VKK CKK OBB CKR	
System accuracy	X		MSC-EL MSC-SH CKP CKK	Drive type: pneumatic ▶ Repeatability of single axis up to ±0.01 mm at end stop Drive type: screw drive ▶ Repeatability of single axis up to ±0.005 mm over the entire travel range
	Z		MSC-EL MSC-SH VKK CKP CKK	

Electromechanical ■ Pneumatic ■

* The values serve as a guide only.

Linear gantry

Linear gantries are classic Cartesian units for X-Z motion that are built using modular components. They are based on a horizontal linear system which carries the vertical Z-axis and guides it in the X direction. This allows two-dimensional motion in the X-Z plane for moving workpieces and other loads. Compared to pick & place systems, linear gantries are designed for longer travel and can handle heavier loads.

Application example for a linear gantry with the focus on

- ▶ High speeds
- ▶ Slim, compact construction
- ▶ Small parts handling
- ▶ Good synchronization capability

Application areas

- ▶ Loading and unloading
- ▶ Feed systems
- ▶ Re-positioning
- ▶ Packing

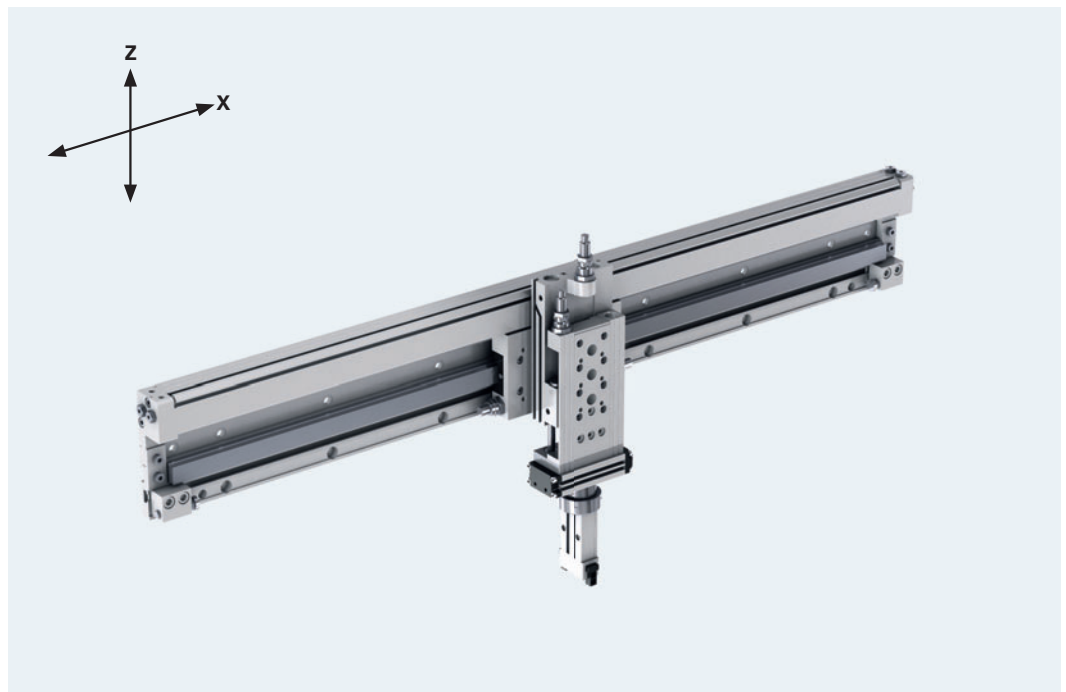

Application example for a linear gantry with the focus on

- ▶ High speeds
- ▶ Very long strokes
- ▶ Bulky, difficult-to-handle workpieces
- ▶ Large-format workpieces
- ▶ Good synchronization capability

Application areas

- ▶ Loading and unloading
- ▶ Feed systems
- ▶ Re-positioning and palletizing
- ▶ Packing
- ▶ Separating
- ▶ Printing and dispensing



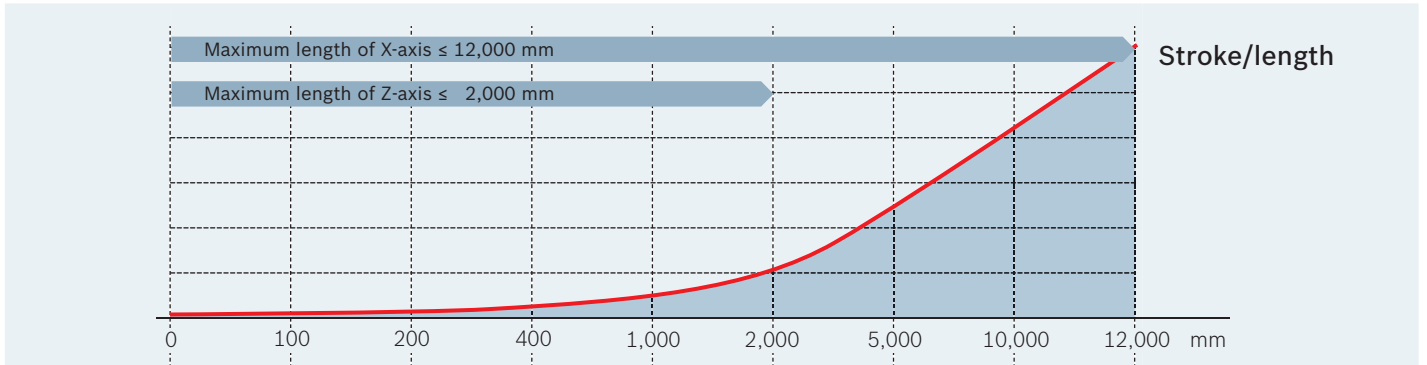

	Axis	Load capacity	Recommended components in relation to stroke/length *	Features *
Load	X		RTC-HD CKP MKK BKK CKK	Guide: single-rail, running track integrated in frame (MSC, RTC, VKK, MKK, OBB) ▶ Payload up to 15 kg Guide: two-rail (OBB, CKP, CKK, BKK) ▶ Payload up to 70 kg
	Z		MSC-SH RTC-CG VKK CKP MKK CKK OBB	
Dynamics	X		GSU RTC-CG RTC-HD MLR CKP MKK BKK CKK MKR BKR CKR	Drive type: pneumatic, screw drive ▶ Fast cycling ▶ For stroke lengths ≤ 400 mm Drive type: toothed belt ▶ Speed up to 5 m/s ▶ Speed up to 10 m/s (MLR) ▶ Acceleration up to 50 m/s ²
	Z		GPC-E MSC-EL MSC-Sx VKK MLR CKP MKK CKK OBB RTC-CG MKR CKR	
System accuracy	X		RTC-HD CKP MKK BKK CKK	Drive type: pneumatic ▶ Repeatability of single axis up to ±0.01 mm at end stop Drive type: screw drive ▶ Repeatability of single axis up to ±0.005 mm over the entire travel range
	Z		MSC-EL MSC-SH RTC-CG VKK CKP MKK CKK	

Electromechanical ■ Pneumatic ■

* The values serve as a guide only.

X-Y table

An X-Y table is a two-axis system which enables objects to be moved horizontally in two dimensions. It consists of two linear systems arranged crosswise, usually at an angle of 90 degrees to each other. This allows a workpiece to be freely positioned anywhere within a square or rectangular area.

Application example for an X-Y table with the focus on

- ▶ Very high precision
- ▶ Low-profile, compact construction

Application area

- ▶ Positioning

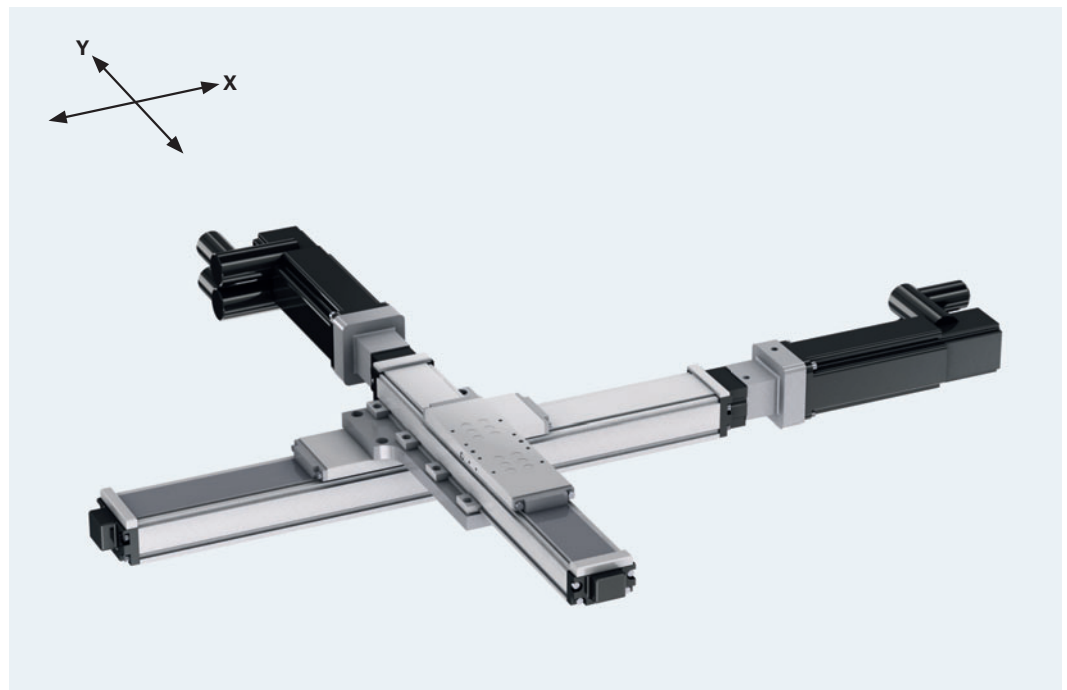

Application example for an X-Y table with the focus on

- ▶ Very high precision
- ▶ Large work zone
- ▶ Heavy loads

Application area

- ▶ Positioning

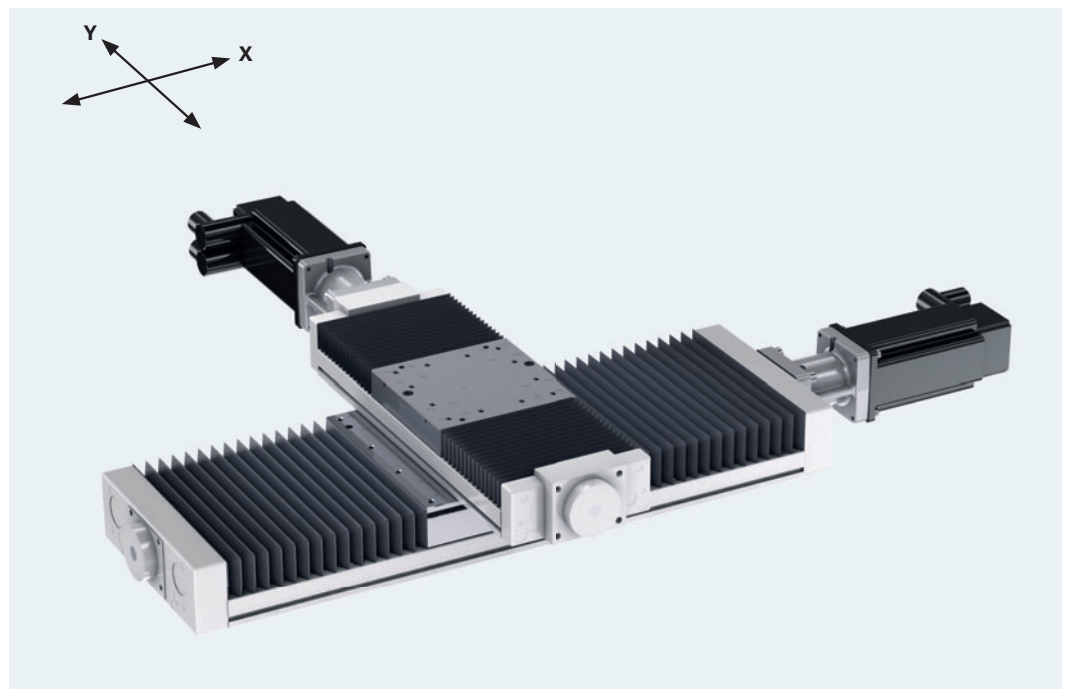

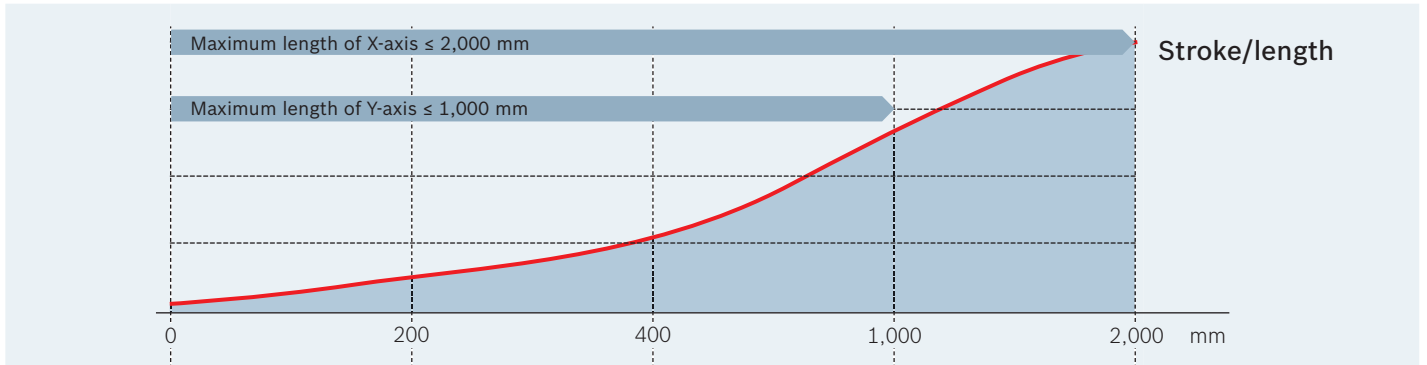

	Axis	Load capacity	Recommended components in relation to stroke/length *	Features *
Load	X	▲	PSK CKK TKK	Guide: running track integrated in frame (PSK) ▶ Payload up to 10 kg Guide: two-rail (CKK, TKK) ▶ Payload up to 100 kg
	Y	▲	PSK CKK TKK	
Dynamics	X	▲	MSC-EL PSK CKK TKK CKR	Drive type: screw drive ▶ Fast cycling ▶ For stroke lengths ≤ 400 mm Drive type: toothed belt ▶ Speed up to 5 m/s ▶ Acceleration up to 50 m/s ²
	Y	▲	MSC-EL PSK CKK TKK CKR	
System accuracy	X	▲	MSC-EL PSK CKK TKK	Drive type: screw drive ▶ Repeatability of single axis up to ±0.005 mm over the entire travel range
	Y	▲	MSC-EL PSK CKK TKK	

Electromechanical ■ Pneumatic ■

* The values serve as a guide only.

Cantilever gantry

A cantilever system is a Cartesian robot capable of moving in the X, Y and Z axes, whose Y-axis is an extendable boom and is carried by a linear system that can travel in the X direction. The Z-axis is then mounted on the boom, thus creating a cuboid work zone with few obstructing contours, as the Y-axis can be retracted. The design of the systems allows long travel in the X direction, while travel in the Y direction is restricted due to the boom axis.

Application example for a cantilever system with the focus on

- ▶ Fast cycling
- ▶ Compact construction
- ▶ Small parts handling

Application areas

- ▶ Insertion and placement of parts
- ▶ Loading and unloading
- ▶ Re-positioning

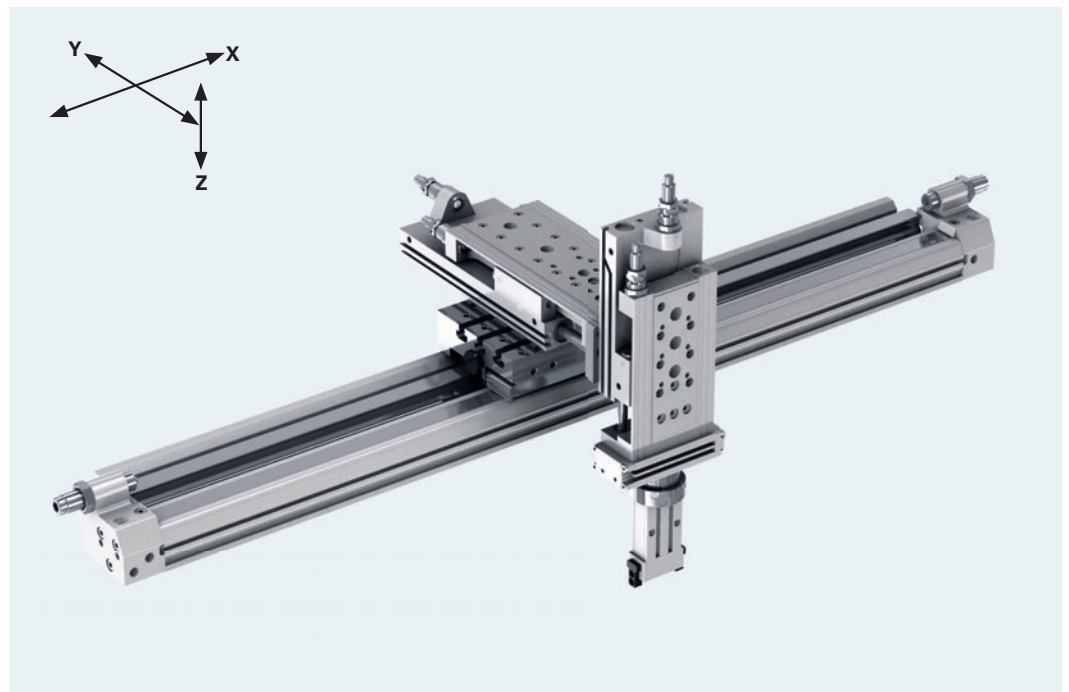

Application example for a cantilever system with the focus on

- ▶ High speeds
- ▶ Large work zone
- ▶ Bulky, difficult-to-handle workpieces
- ▶ Large-format workpieces

Application areas

- ▶ Insertion and placement of parts
- ▶ Loading and unloading
- ▶ Re-positioning

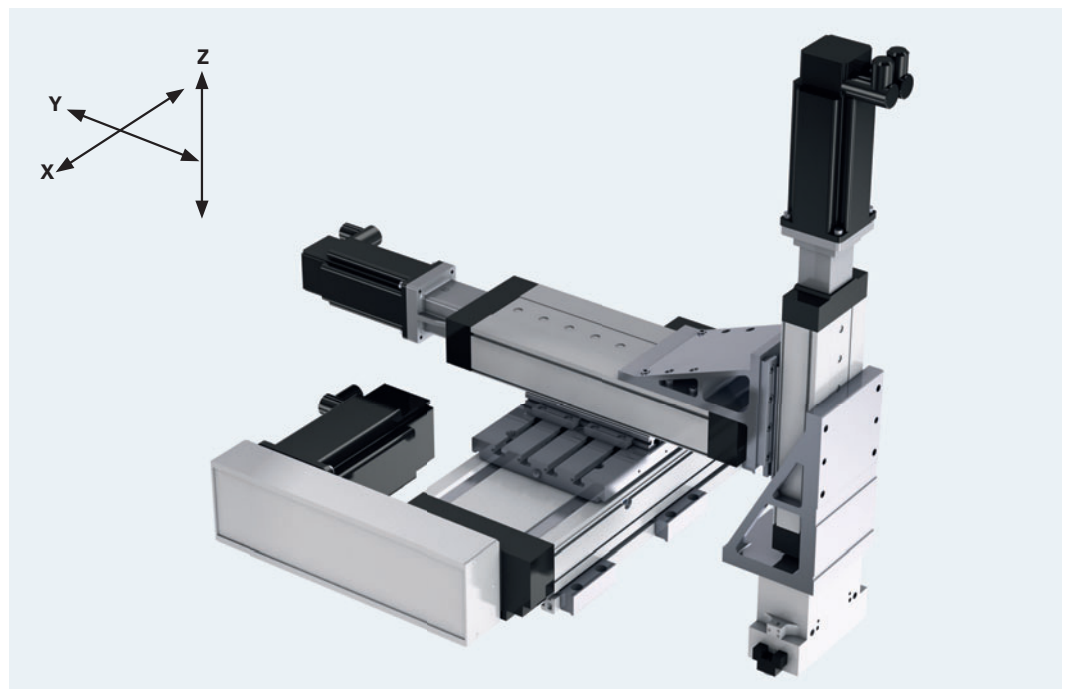

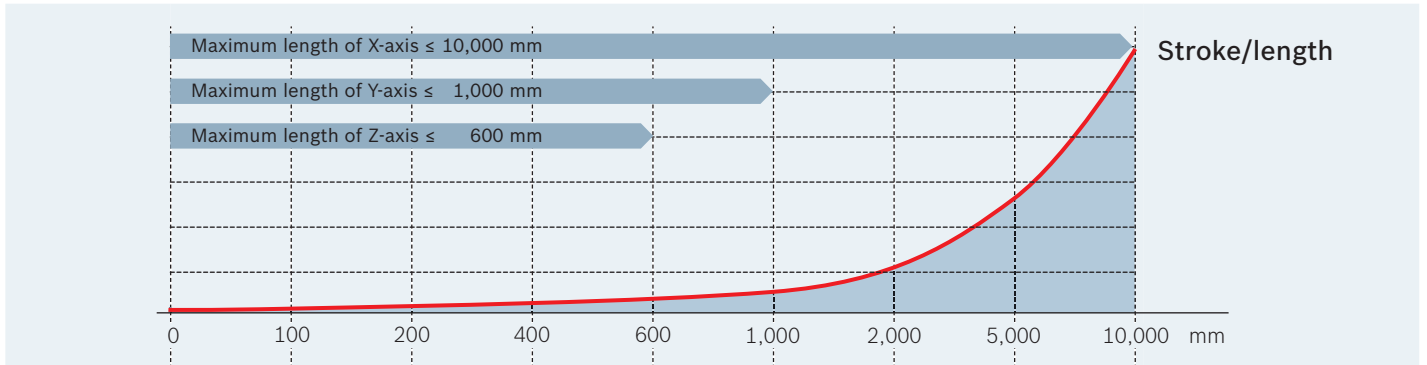

	Axis	Load capacity	Recommended components in relation to stroke/length *	Features *
Load	X		RTC-HD CKP BKK CKK	Guide: single-rail, running track integrated in frame (MSC, VKK, RTC, OBB) ▶ Payload up to 10 kg Guide: two-rail (OBB, CKP, BKK, CKK) ▶ Payload up to 30 kg
	Y		MSC-SH CKP CKK	
	Z		MSC-SH VKK CKP CKK OBB	
Dynamics	X		GSU RTC-CG RTC-HD BKK CKK BKR CKR	Drive type: pneumatic, screw drive ▶ Fast cycling ▶ For stroke lengths ≤ 400 mm Drive type: toothed belt ▶ Speed up to 5 m/s ▶ Acceleration up to 50 m/s ²
	Y		GPC-E MSC-EL MSC-Sx CKP OBB CKK CKR	
	Z		GPC-E MSC-EL MSC-Sx VKK CKK OBB CKR	
System accuracy	X		RTC-HD CKP BKK CKK	Drive type: pneumatic ▶ Repeatability of single axis up to ±0.01 mm at end stop Drive type: screw drive ▶ Repeatability of single axis up to ±0.005 mm over the entire travel range
	Y		MSC-EL MSC-SH CKP CKK	
	Z		MSC-EL MSC-SH VKK CKP CKK	

Electromechanical ■ Pneumatic ■

* The values serve as a guide only.

H-type gantry

H-type gantries are Cartesian robots that can travel in the X, Y and Z directions and are based on a linear axis system that moves in the X-Y plane and carries a vertical Z-axis. The X-axes are mechanically or electrically synchronized. It is also possible to have a master-slave version. This results in a cuboid work zone in which workpieces can be moved in all three directions by grippers or other tools. Rotary axes or multiple grippers can also be installed. H-type gantries enable parts to be carried large distances and can handle heavy loads with very high precision.

Application example for an H-type gantry with the focus on

- ▶ 3D handling
- ▶ Compact construction
- ▶ Small parts handling

Application areas

- ▶ Loading and unloading
- ▶ Re-positioning
- ▶ Packing
- ▶ Dispensing

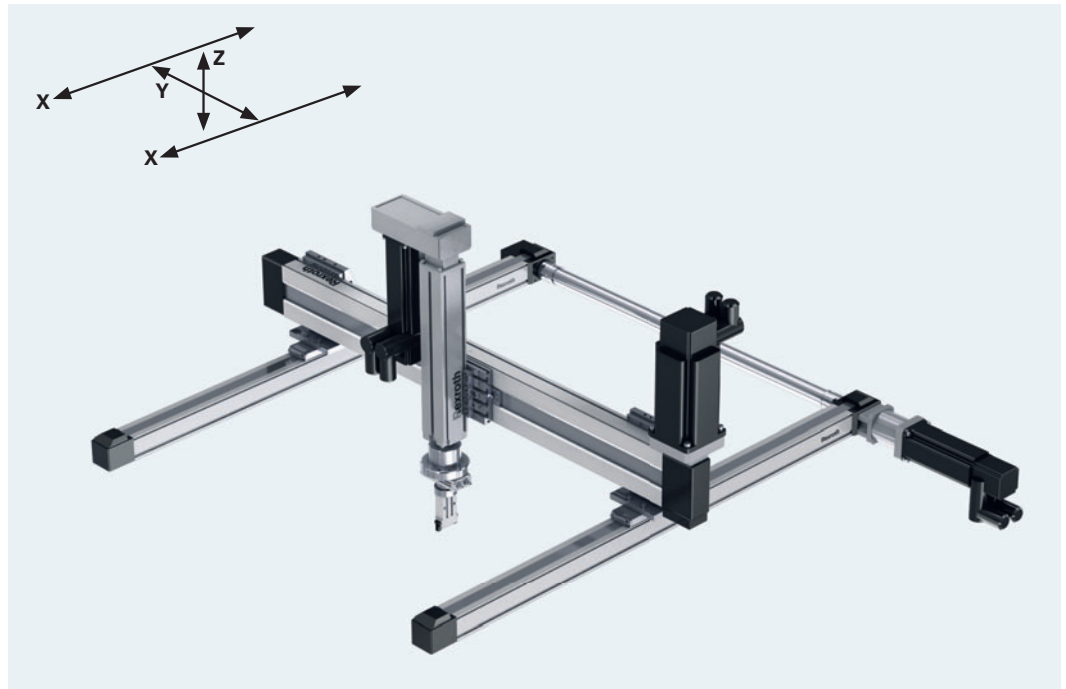

Application example for an H-type gantry with the focus on

- ▶ 3D handling
- ▶ Large work zone
- ▶ High loads
- ▶ Bulky, difficult-to-handle workpieces
- ▶ Large-format workpieces

Application areas

- ▶ Loading and unloading
- ▶ Re-positioning
- ▶ Palletizing
- ▶ Packing
- ▶ Dispensing

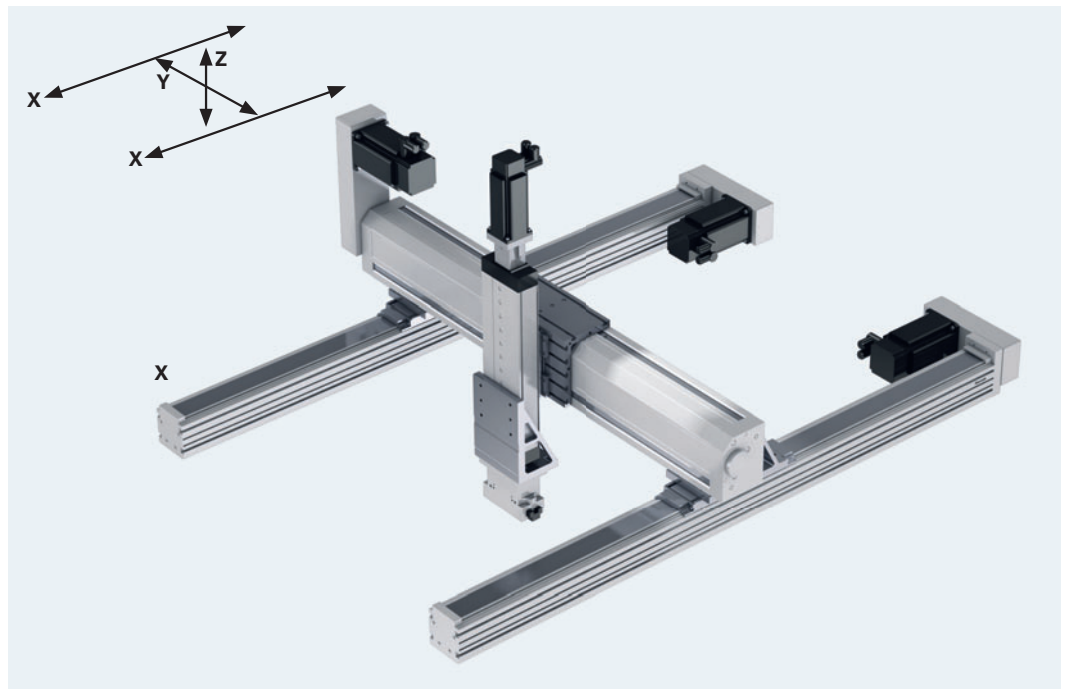

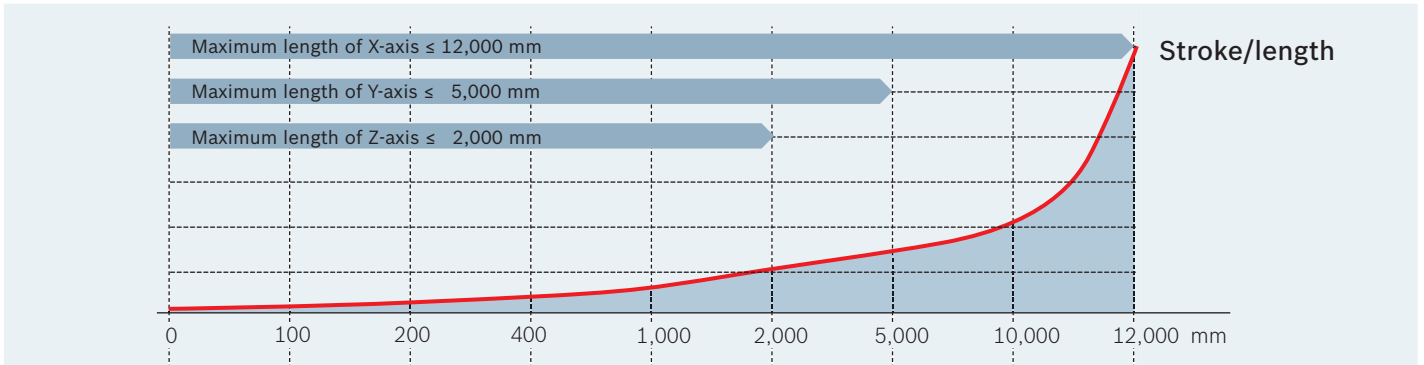

	Axis	Load capacity	Recommended components in relation to stroke/length *	Features *
Load	X		MKR MKK CKR CKK	Guide: single-rail, running track integrated in frame (MSC, VKK, OBB) ▶ Payload up to approx. 15 kg Guide: two-rail (2x MKK, 2x MKR, CKK, CKR, BKK, OBB) ▶ Payload up to 70 kg
	Y		CKP CKK BKK	
	Z		MSC-SH VKK CKP CKK OBB	
Dynamics	X		MKR CKR	Drive type: pneumatic, screw drive ▶ Fast cycling ▶ For stroke lengths ≤ 400 mm Drive type: toothed belt ▶ Speed up to 5 m/s ▶ Acceleration up to 50 m/s ²
	Y		CKP CKK BKK CKR BKR	
	Z		MSC-EL MSC-Sx CKK OBB CKR	
System accuracy	X		MKK CKK	Drive type: pneumatic ▶ Repeatability of single axis up to ±0.01 mm at end stop Drive type: screw drive ▶ Repeatability of single axis up to ±0.005 mm over the entire travel range
	Y		CKP CKK BKK	
	Z		MSC-EL MSC-SH VKK CKP CKK	

Electromechanical ■ Pneumatic ■

* The values serve as a guide only.

Components



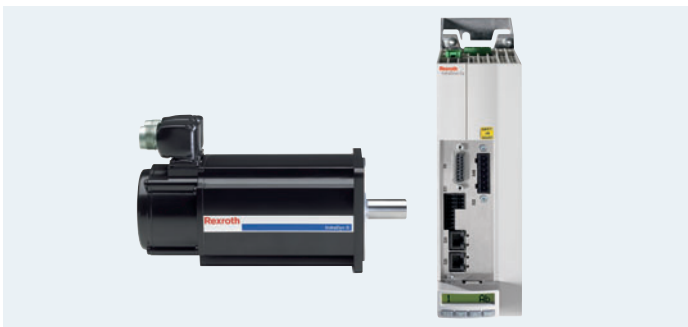

20 Components

- 22 Highlights and options
- 24 Linear modules (MKK, MKR, MLR, OBB, RTC-CG/-HD, GSU)
- 28 Compact modules (CKK, CKR, CKP)
- 30 Bridge modules (BKK, BKR)
- 32 Precision Modules (PSK)
- 33 Ball rail tables (TKK)
- 34 Mini slides (MSC-EL, MSC-Sx)
- 36 Feed modules (VKK, GPC-E)
- 38 Rotary compact modules
- 39 Rotary indexing tables
- 40 Grippers
- 42 Pneumatic valves
- 43 Vacuum technology
- 44 Servo motors, linear motors
- 46 Compact electric drives
- 48 Compact controls
- 49 I/O technology
- 50 Visualization
- 51 Further components and systems

Highlights and options

Versatile linear systems to meet every need

Our linear systems offer a large variety of configuration options, allowing you to choose the ones that precisely match your application requirements:

- ▶ Ready-to-install linear systems in any length up to 12 m
- ▶ Application-optimized design styles
- ▶ Motor attachment to any side of the linear system
- ▶ Variable feed/lead constants
- ▶ Long, short and multiple carriage designs
- ▶ Screw supports for very long strokes
- ▶ Different covers and sealing options

- ▶ Mechanical interfaces for attaching an extensive range of accessories, such as switches, linear encoders and connection technology

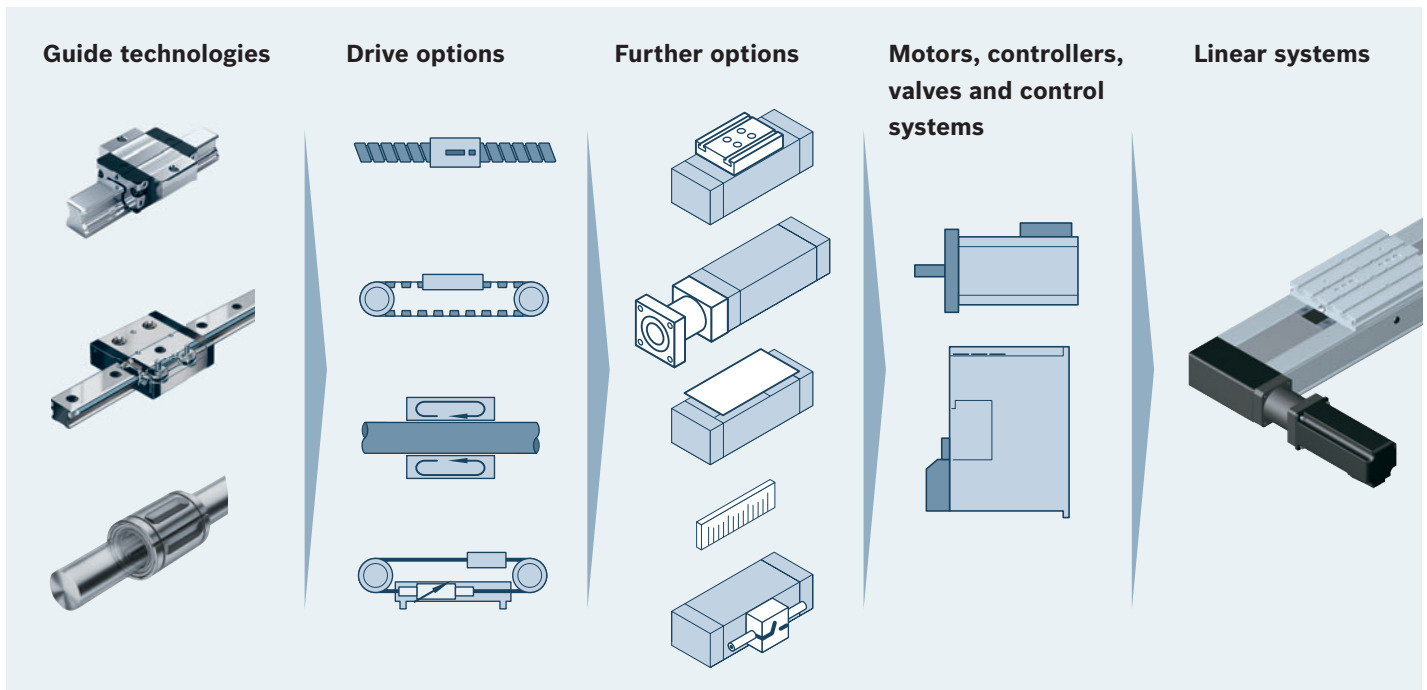

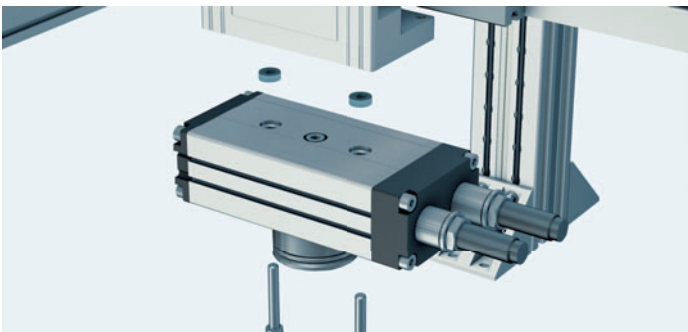

**Easy-2-Combine interface –
precise and rapid mounting**

Easy-2-Combine considerably reduces your assembly effort as the mechanical modules have positive-locking interfaces. Direct connection without intermediate plates results in accurate assembly, high structural integrity, minimal space requirement, minimal weight, and high dynamics.



**EasyWizard –
fast start-up for greater flexibility**

Configuring the electrical components couldn't be easier: All the axis-specific electrical and mechanical data are already stored in the smart EasyWizard start-up assistant. That reduces the time needed to configure and start up complete axes to just a few minutes.



**Multiple-protocol interface –
for flexible communication**

The newly developed compact drives with multiple protocol capability fulfill rising demands for openness and compatibility. Connection of the Ethernet-based interfaces is done using universal communication hardware that is easily configured with the software provided. Available interfaces are: sercos III, PROFINET IO, EtherNet/IP, EtherCat.

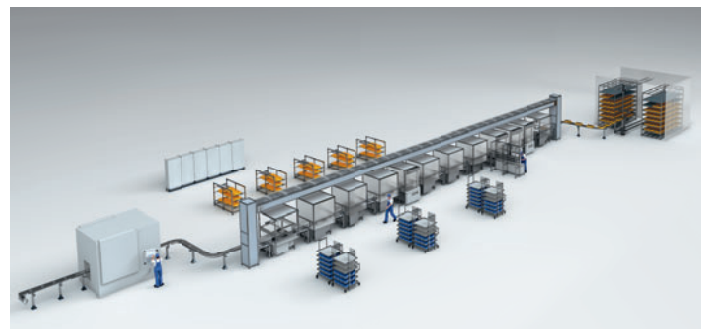

**IndraMotion for Handling –
turnkey automation solution**

IndraMotion for Handling is the ideal system solution for efficient coordination of axis movements in fully automated production processes. The intelligent concept is based on standardized control and drive platforms and international software standards. Precise synchronization of all components gives you the freedom to implement your handling application exactly the way you planned it.

Linear modules

Linear modules are ready-to-install, field-proven linear systems in single-rail design with extremely compact dimensions. High load capacities and optimal travel performance enable the integrated, zero-clearance guides to move large loads at high speed. The wide range of available drive types and the high system rigidity that allows self-supporting installation give you maximum leeway for designing custom handling applications.

MKK – linear module with ball screw drive and ball rail system

Advantages

- ▶ High positioning accuracy and repeatability
- ▶ Slim design

Features

- ▶ Drive type: ball screw drive
- ▶ Guide: ball rail system
- ▶ Positioning: free
- ▶ Frame: extruded, anodized aluminum profile
- ▶ Motor attachment: direct or via timing belt side drive
- ▶ Screw: available in various leads and with screw supports
- ▶ Protection: various sealing strips and longitudinal seals available
- ▶ Options: customized switch mounting arrangements possible; also available without drive as a slave axis



MKR – linear module with toothed belt drive and ball rail system

Advantages

- ▶ High speeds
- ▶ High acceleration
- ▶ Slim design

Features

- ▶ Drive type: toothed belt
- ▶ Guide: ball rail system
- ▶ Positioning: free
- ▶ Frame: extruded, anodized aluminum profile
- ▶ Motor attachment: direct or via gear unit
- ▶ Gear unit: choice of gear ratios
- ▶ Protection: various sealing strips and longitudinal seals available
- ▶ Options: second drive journal, customized switch mounting arrangements possible; also available without drive as a slave axis





MLR – linear module with toothed belt drive and cam roller guide

Advantages

- ▶ Very high speeds
- ▶ High acceleration
- ▶ Slim design

Features

- ▶ Drive type: toothed belt
- ▶ Guide: cam roller guide
- ▶ Positioning: free
- ▶ Frame: extruded, anodized aluminum profile
- ▶ Motor attachment: direct or via gear unit
- ▶ Gear unit: choice of gear ratios
- ▶ Protection: sealing via belt guided in slots
- ▶ Options: second drive journal, customized switch mounting arrangements possible; also available without drive as a slave axis



OBB – linear module with omega toothed belt and ball rail system

Advantages

- ▶ High dynamics and speeds through reduction of moved frame mass
- ▶ Deep penetration into work zones and long travel in vertical and horizontal directions
- ▶ Multiple, independently movable carriages possible

Features

- ▶ Drive type: omega toothed belt
- ▶ Guide: ball rail system
- ▶ Positioning: free
- ▶ Frame: extruded, anodized aluminum profile
- ▶ Motor attachment: direct or via gear unit
- ▶ Gear unit: choice of gear ratios
- ▶ Options: several carriages per frame, clamping unit to hold a position, second drive journal, customized switch mounting arrangements possible

RTC-CG / RTC-HD – linear module with rodless pneumatic drive and ball rail system

Advantages

- ▶ High speeds
- ▶ Long strokes possible

Features

- ▶ Drive type: rodless pneumatic drive
- ▶ Guide: ball rail system
- ▶ Positioning: via adjustable end stop
- ▶ Frame: extruded, anodized aluminum profile
- ▶ Air ports: on both sides
- ▶ Options: sensors for flexible position detection, flexible switch mounting arrangements possible, pneumatic and hydraulic shock absorbers, adjustable cushioning



Linear module *		MKK	MKR	MLR
Sizes		5	6	2
Drive unit		Ball screw drive	Toothed belt	Toothed belt
Guide		Ball rail system	Ball rail system	Cam roller guide
Max. length	mm	4,900	12,000	10,000
Max. stroke	mm	–	–	–
Max. travel speed	m/s	2.5	5	10
Repeatability up to	mm	±0.005	±0.1	±0.1
Max. moment load M_L	Nm	2,085	7,300	302
Max. moment load M_T	Nm	723	2,850	49
Max force in direction of travel	N	19,790	5,250	1,740
Max. permissible drive torque	Nm	140	367	80
Typical use		X-axis in a linear gantry	X-axis in a linear gantry	X-axis in a linear gantry
		X-axes in an H-type gantry	X-axes in an H-type gantry	X-axes in an H-type gantry

* The stated maximum values apply to all sizes of that type.



GSU – linear module with rodless pneumatic drive and ball rail system

Advantages

- ▶ High speeds
- ▶ Very low profile

Features

- ▶ Drive type: rodless pneumatic drive
- ▶ Guide: ball rail system
- ▶ Positioning: via adjustable end stop
- ▶ Frame: extruded, anodized aluminum profile
- ▶ Air ports: on both sides
- ▶ Options: sensors for flexible position detection, customized switch mounting arrangements possible, hydraulic shock absorbers, self-adjusting cushioning

OBB	RTC-CG / RTC-HD	GSU
3	4 / 6	2
Omega toothed belt	Rodless pneumatic drive	Rodless pneumatic drive
Ball rail system	Ball rail system	Ball rail system
5,500	–	–
–	2,000 / 4,300	1,000
5	2	1.5
±0.1	±0.01	±0.01
8,560	284 / 1,120	65
970	36 / 254	55
2,844	792 / 1,964 (at 6.3 bar)	309 (at 6.3 bar)
154	–	–
X/Z-axis in a pick & place system	X/Z-axis in a linear gantry	X-axis in a linear gantry
Z-axis in a linear gantry	X-axis in a cantilever gantry	X-axis in a cantilever gantry
Y/Z-axis in a cantilever gantry		
Z-axis in an H-type gantry		

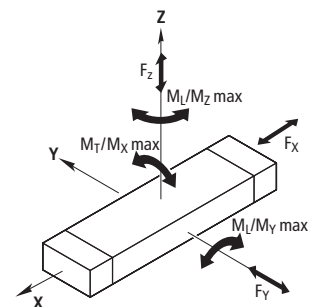

Compact modules

Compact modules are characterized by their high power density. They have two ball rail systems arranged in parallel and can be equipped with one carriage or – if needed to accommodate higher loads – with two carriages. All compact modules have a low profile with a width/height to side ratio of 2:1. In comparison to linear modules with the same size of ball rails, they can carry higher loads although their profile cross-section is smaller.

CKK – Compact module with ball screw drive and ball rail systems

Advantages

- ▶ High positioning accuracy and repeatability
- ▶ High moment load capacity
- ▶ High thrust forces possible
- ▶ High load capacities

Features

- ▶ Drive type: ball screw drive
- ▶ Guide: 2 ball rail systems arranged in parallel
- ▶ Positioning: free
- ▶ Frame: extruded, anodized aluminum profile
- ▶ Motor attachment: direct or via timing belt side drive
- ▶ Screw: available in various leads and with screw supports
- ▶ Protection: gap seal made of polyurethane strip
- ▶ Options: customized switch mounting arrangements possible; an economy version eCKK with reduced performance is also available



CKR – Compact module with toothed belt drive and ball rail systems

Advantages

- ▶ High speeds
- ▶ High acceleration
- ▶ High moment load capacity
- ▶ High load capacities

Features

- ▶ Drive type: toothed belt
- ▶ Guide: 2 ball rail systems arranged in parallel
- ▶ Positioning: free
- ▶ Frame: extruded, anodized aluminum profile
- ▶ Motor attachment: direct or via gear unit
- ▶ Gear unit: choice of gear ratios
- ▶ Protection: sealing via belt guided in slots
- ▶ Options: second drive journal, customized switch mounting arrangements possible, available without drive as a slave axis; an economy version eCKR with reduced performance is also available





CKP – Compact module with rodless pneumatic drive and ball rail systems

Advantages

- ▶ High speeds
- ▶ High moment load capacity
- ▶ High load capacities

Features

- ▶ Drive type: rodless pneumatic drive
- ▶ Guide: 2 ball rail systems arranged in parallel
- ▶ Positioning: via adjustable end stop
- ▶ Frame: extruded, anodized aluminum profile
- ▶ Air ports: on both sides
- ▶ Options: sensors for flexible position detection, flexible switch mounting arrangements possible, adjustable pneumatic cushioning

Compact modules *	CKK	CKR	CKP
Sizes	5	5	3
Drive unit	Ball screw drive	Toothed belt	Rodless pneumatic drive
Guide	2 ball rail systems arranged in parallel	2 ball rail systems arranged in parallel	2 ball rail systems arranged in parallel
Max. length	mm 5,500	10,000	–
Max. stroke	mm –	–	3,500
Max. travel speed	m/s 2.53	5	2
Repeatability up to	mm ±0.005	±0.1	±0.01
Max. moment load M_L	Nm 2,999	3,000	867
Max. moment load M_T	Nm 2,228	2,230	687
Max force in direction of travel	N 7,240	2,830	507 (at 6.3 bar)
Max. permissible drive torque	Nm 41	112.7	–
Typical use	X/Z-axis in a pick&place system X/Z-axis in a linear gantry X/Y-axis for X-Y table X/Y/Z-axis in a cantilever gantry X/Y/Z-axis in an H-type gantry	X/Z-axis in a pick&place system X/Z-axis in a linear gantry X/Y-axis for X-Y table X/Y/Z-axis in a cantilever gantry X/Y/Z-axis in an H-type gantry	X/Z-axis in a pick&place system X/Z-axis in a linear gantry X/Y/Z-axis in a cantilever gantry Y/Z-axis in an H-type gantry

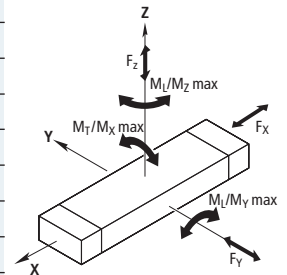

* The stated maximum values apply to all sizes of that type.

Bridge modules

Bridge modules are ready-to-install, highly integrated linear systems with two guide rails for self-supporting bridging of long distances, such as needed in H-type gantries. They provide neat solutions for applications that could otherwise only be served by costly custom designs. Thanks to their torsional stiffness and load-bearing capability, they are ideal for moving large masses at high speed. The wide range of available drive options gives maximum leeway for designing custom handling applications.

BKK – Bridge module with ball screw drive and ball rail systems

Advantages

- ▶ High positioning accuracy and repeatability
- ▶ High moment load capacity
- ▶ High load capacities
- ▶ Self-supporting bridging of long distances

Features

- ▶ Drive type: ball screw drive
- ▶ Guide: 2 ball rail systems arranged at an angle of 90°
- ▶ Positioning: free
- ▶ Frame: extruded, anodized aluminum profile
- ▶ Carriage: angled carriage
- ▶ Motor attachment: direct or via timing belt side drive
- ▶ Screw: available in various leads and with screw supports
- ▶ Protection: gap-type seals
- ▶ Options: customized switch mounting arrangements possible



BKR – Bridge module with toothed belt drive and ball rail systems

Advantages

- ▶ High speeds
- ▶ High acceleration
- ▶ High moment load capacity
- ▶ High load capacities
- ▶ Self-supporting bridging of long distances

Features

- ▶ Drive type: toothed belt
- ▶ Guide: 2 ball rail systems arranged at an angle of 90°
- ▶ Positioning: free
- ▶ Frame: extruded, anodized aluminum profile
- ▶ Carriage: angled carriage
- ▶ Motor attachment: direct or via gear unit
- ▶ Gear unit: choice of gear ratios
- ▶ Protection: gap seal made of polyurethane strip
- ▶ Options: second drive journal, customized switch mounting arrangements possible



Bridge module *		BKK	BKR
Sizes		2	2
Drive unit		Ball screw drive	Toothed belt
Guide		2 ball rail systems arranged at an angle of 90°	2 ball rail systems arranged at an angle of 90°
Max. length	mm	5,000	5,800
Max. travel speed	m/s	1.6	5
Repeatability up to	mm	±0.005	±0.1
Max. moment load M_L	Nm	1,830	1,690
Max. moment load M_T	Nm	1,410	1,370
Max force in direction of travel	N	6,530	2,783
Max. permissible drive torque	Nm	37	151
Typical use		X-axis in a linear gantry	X-axis in a linear gantry
		X-axis in a cantilever gantry	X-axis in a cantilever gantry
		Y-axis in an H-type gantry	Y-axis in an H-type gantry

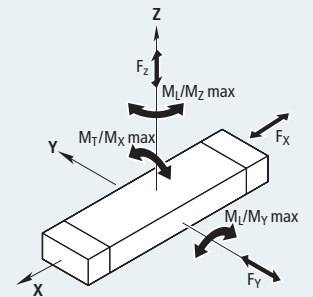

* The stated maximum values apply to all sizes of that type.

Precision modules

In addition to their outstanding performance features and small dimensions, precision modules will convince you with their superior accuracy. The compact design and rigidity is due to the precision steel profiles of the frame with integrated Rexroth guideway geometry. Equipped with high-quality ball screws with backlash-free nut systems, these modules achieve exceptionally high positioning accuracy and repeatability in tolerance grade 7 – and at high travel speeds.

PSK – Precision module with ball screw drive and integrated guideway geometry

Advantages

- ▶ High positioning accuracy and repeatability
- ▶ Highly rigid steel profile
- ▶ Easy alignment

Features

- ▶ Drive type: ball screw drive
- ▶ Guide: steel frame with integrated guideway geometry
- ▶ Positioning: free
- ▶ Frame: steel profile
- ▶ Motor attachment: direct or via timing belt side drive
- ▶ Screw: various leads available
- ▶ Protection: choice of plate covers and sealing strips
- ▶ Options: customized switch mounting arrangements possible



Precision module *	PSK
Sizes	4
Drive unit	Ball screw drive
Guide	Steel frame with integrated guideway geometry
Max. length	mm 940
Max. travel speed	m/s 1.6
Repeatability up to	mm ± 0.005
Max. moment load M_L	Nm 1,228
Max. moment load M_T	Nm 739
Max force in direction of travel	N 1,830
Max. permissible drive torque	Nm 5.2
Typical use	X/Y-axis for X-Y table

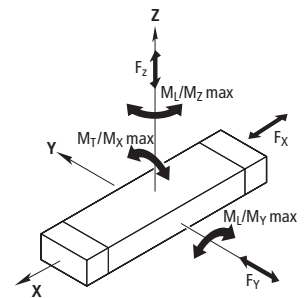

* The stated maximum values apply to all sizes of that type.

Ball rail tables

Our ready-to-install ball rail tables will help you solve demanding linear motion tasks rapidly and cost-effectively – from simple single-axis systems to multi-axis configurations. Incorporating ball rail systems with four long high-precision runner blocks per carriage, they offer exceptional load-bearing capacity and rigidity. Moreover, they also achieve high travel speeds over long distances thanks to large screw diameters and leads, and double floating bearings. Their internal components are protected by high-quality, welded bellows that are resistant to oil, moisture and temperature.



TKK – Ball rail table with ball screw drive and ball rail systems

Advantages

- ▶ High positioning accuracy and repeatability
- ▶ Very high load capacity
- ▶ High torsional and longitudinal moment capability due to widely spaced guide rails and runner block arrangement
- ▶ Easy alignment

Features

- ▶ Drive type: ball screw drive
- ▶ Guide: two parallel ball rail systems, each with two long runner blocks
- ▶ Positioning: free
- ▶ Frame: base plate made of machined aluminum profile or steel with reference edge
- ▶ Motor attachment: direct or via timing belt side drive
- ▶ Screw: various leads available
- ▶ Protection: polyurethane bellows
- ▶ Options: customized switch mounting arrangements and linear position sensing systems possible

Ball rail table *	TKK
Sizes	4
Drive unit	Ball screw drive
Guide	Two parallel ball rail systems, each with two long runner blocks
Max. length	mm 2,860
Max. travel speed	m/s 1.5
Repeatability up to	mm ± 0.005
Max. moment load M_L	Nm 13,930
Max. moment load M_T	Nm 13,210
Max force in direction of travel	N 19,360
Max. permissible drive torque	Nm 137
Typical use	X/Y-axis for X-Y table

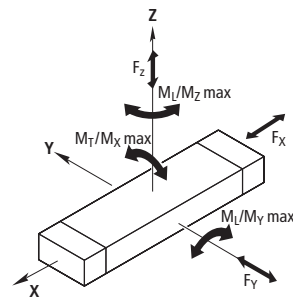

* The stated maximum values apply to all sizes of that type.

Mini slides

The ready-to-install mini slides come with their own, integrated electric drive. A maintenance-free, brushless, electronically commutated DC motor, the timing belt side drive and the ball screw drive are completely embedded inside the linear system. This reduces the start-up effort to a few simple actions. As an alternative to the electrically driven mini slide there is a pneumatically driven model which has the same connection dimensions and mounting hole pattern.

MSC-EL – Mini slide with ball screw drive and ball rail system

Advantages

- ▶ High repeatability
- ▶ Very compact design

Features

- ▶ Drive type: ball screw drive
- ▶ Guide: ball rail system with steel insert
- ▶ Positioning: free
- ▶ Frame: extruded, anodized aluminum profile
- ▶ Motor: integrated
- ▶ Options: customized switch mounting arrangements possible



MSC-Sx – Mini slide with pneumatic drive and ball rail system

Advantages

- ▶ Fast cycling
- ▶ Low profile
- ▶ Compact design
- ▶ High power density due to dual-piston drive

Features

- ▶ Drive type: pneumatic
- ▶ Guide: ball rail system
- ▶ Positioning: adjustable end stop
- ▶ Cushioning: hydraulic or elastomer
- ▶ Air ports: on both sides
- ▶ Options: electromagnetic sensors for flexible position sensing



Mini slides *		MSC-EL	MSC-Sx
Sizes		4	5
Drive unit		Ball screw drive	Pneumatic drive
Guide		Ball rail system with steel insert	Ball rail system
Max. stroke	mm	200	200
Max. travel speed	m/s	0.38	0.8
Repeatability up to	mm	±0.01	±0.01
Max. moment load M_L	Nm	47	236
Max. moment load M_T	Nm	47	145
Max force in direction of travel	N	140	619 (at 6.3 bar)
Typical use		X/Z-axis in a pick & place system	X/Z-axis in a pick & place system
		Z-axis in a linear gantry	Z-axis in a linear gantry
		X/Y-axis for X-Y table	
		Y/Z-axis in a cantilever gantry	Y/Z-axis in a cantilever gantry
		Z-axis in an H-type gantry	Z-axis in an H-type gantry

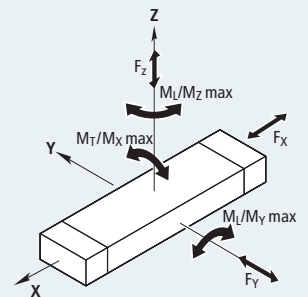

* The stated maximum values apply to all sizes of that type.

Feed modules

Rexroth's neatly-sized feed modules are especially suitable for handling tasks requiring high precision, high thrust and torque transfer capabilities, and high positioning accuracy and repeatability. Because of their low moved mass, they are ideal for vertical motion in Z-axes.

VKK – Feed module with ball screw drive and ball rail system

Advantages

- ▶ High repeatability
- ▶ System with low moved mass
- ▶ Deep penetration into work zones
- ▶ Compact design

Features

- ▶ Drive type: ball screw drive
- ▶ Guide: ball guide rails made of wrought aluminum alloy with running tracks of hardened antifriction bearing steel
- ▶ Positioning: free
- ▶ Frame: extruded, anodized aluminum profile
- ▶ Motor attachment: direct or via timing belt side drive
- ▶ Screw: various leads available
- ▶ Options: customized switch mounting arrangements possible



GPC-E – Feed module with pneumatic drive and linear bushing guide

Advantages

- ▶ Fast cycling
- ▶ Low profile
- ▶ Compact design

Features

- ▶ Drive type: pneumatic drive
- ▶ Guide: 2 linear bushing guides arranged in parallel
- ▶ Positioning: adjustable end stop
- ▶ Cushioning: hydraulic and elastomer
- ▶ Air ports: on both sides
- ▶ Options: electromagnetic sensors for flexible position sensing



Feed module *		VKK	GPC-E
Sizes		3	3
Drive unit		Ball screw drive	Pneumatic drive
Guide		Ball rail system with steel insert	2 linear bushing guides arranged in parallel
Max. stroke	mm	400	150
Max. travel speed	m/s	1.2	0.5
Repeatability up to	mm	±0.01	±0.01
Max. moment load M_L	Nm	360	-
Max. moment load M_T	Nm	100	-
Max force in direction of travel	N	7,200	198 (at 6.3 bar)
Max. permissible drive torque	Nm	25.5	-
Typical use		Z-axis in a pick & place system	X/Z-axis in a pick & place system
		Z-axis in a linear gantry	Z-axis in a linear gantry
		Z-axis in a cantilever gantry	Y/Z-axis in a cantilever gantry
		Z-axis in an H-type gantry	

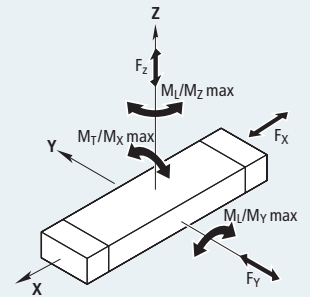

* The stated maximum values apply to all sizes of that type.

Rotary compact modules

Series RCM rotary compact modules cover practically all applications requiring standard rotary and swivel movements. The modules can be directly mounted to linear systems and fitted with mechanical grippers. With functions like pneumatic intermediate positions, integrated elastomer or hydraulic end-position cushioning and metal stops at the end positions, they provide multiple options for achieving maximum precision and great flexibility.

RCM – Rotary compact module with pneumatic drive

Advantages

- ▶ High repeatability thanks to backlash-free rotary table bearing
- ▶ Flexible swivel angle thanks to adjustable end positions
- ▶ Optional, steplessly adjustable intermediate position-setting function
- ▶ Direct movement to intermediate position from both end positions
- ▶ Elimination of interfering tubing due to direct air feed-through

Features

- ▶ Drive type: pneumatic drive
- ▶ Kinematics: rack and pinion
- ▶ Guide: ball bearing
- ▶ Rotary angle: 0° to 180°
- ▶ Positioning: adjustable end positions
- ▶ Cushioning: hydraulic or elastomer
- ▶ Air feed-through: with/without
- ▶ Intermediate position: with/without
- ▶ Options: extensive range of sensors for a variety of polling functions as well as position monitoring



Rotary compact module *	RCM	
Sizes		6
Swivel angle	°	90, 180
Max. torque (6 bar)	Nm	6.5
Repeatability up to	°	±0.025
Cushioning		Elastomer
		Hydraulic

* The stated maximum values apply to all sizes of that type.

Rotary indexing tables

Pneumatically driven rotary indexing tables of the RWT series make it easy to accomplish indexed positioning tasks. The units rotate clockwise or counterclockwise with an angle of rotation of 45°, 60° or 90°. The indexing tables can be equipped with sensors for reliable position monitoring.



RWT – Rotary indexing table with pneumatic drive

Advantages

- ▶ Fast swiveling
- ▶ Easy to install
- ▶ Robust mechanics

Features

- ▶ Drive type: pneumatic
- ▶ Kinematics: ratchet mechanism
- ▶ Guide: ball bearing
- ▶ Rotary angle: 45°, 60°, 90°
- ▶ Mounting: countersunk locating features for fixing
- ▶ Options: extensive range of sensors for a variety of polling functions as well as position monitoring

Rotary indexing tables *		RWT
Sizes		1
Rotation angle	°	45, 60, 90
Direction of rotation		Clockwise/counterclockwise
Max. torque (6 bar)	Nm	1.2
Repeatability	°	±0.1

* The stated maximum values apply to all sizes of that type.

Grippers

With its extensive range of grippers Rexroth offers a wealth of choices to master the different tasks in handling technology. Each model comes in several sizes, thus covering the requirements of nearly all standard applications. With precise and robust guidance of the gripper fingers, these pneumatic grippers provide high accuracy and reliability in continuous operation.



GSP-A – Angular gripper for small to medium-sized workpieces

Advantages

- ▶ Robust kinematics for high force transmission and synchronized gripping
- ▶ Hard-anodized or hardened functional elements for long life

- ▶ Jaws equipped with centering sleeves for adaptation to workpiece-specific gripper fingers
- ▶ Compact dimensions minimize interfering contours

Features

- ▶ Drive type: pneumatic
- ▶ Kinematics: involute gears
- ▶ Working principle: double-acting
- ▶ Options: extensive range of sensors for a variety of polling functions as well as position monitoring



GSP-P – Parallel gripper for small to medium-sized workpieces

Advantages

- ▶ With/without gripping force retention
- ▶ Robust, ground T-slot sliding guides for maximum precision and synchronized gripping
- ▶ Hard-anodized or hardened functional elements for long life

- ▶ Jaws equipped with centering sleeves for adaptation to workpiece-specific gripper fingers
- ▶ Compact dimensions minimize interfering contours

Features

- ▶ Drive type: pneumatic
- ▶ Kinematics: inclined plane / wedge-hook
- ▶ Working principle: double-acting; double-acting, pressureless when closed; double-acting, pressureless when open
- ▶ Options: extensive range of sensors



GSP-R – Radial gripper for small to medium-sized workpieces

Advantages

- ▶ Robust kinematics for high force transmission and synchronized gripping
- ▶ Hard-anodized or hardened functional elements for long life

- ▶ Jaws equipped with centering sleeves for adaptation to workpiece-specific gripper fingers
- ▶ Compact dimensions minimize interfering contours

Features

- ▶ Drive type: pneumatic
- ▶ Kinematics: cam disc
- ▶ Working principle: double-acting
- ▶ Options: extensive range of sensors for a variety of polling functions as well as position monitoring



GSP-Z – Centric gripper for small to medium-sized workpieces

Advantages

- ▶ Robust, ground T-slot sliding guides for maximum precision and synchronized gripping
- ▶ Hard-anodized or hardened functional elements for long life

- ▶ Jaws equipped with centering sleeves for adaptation to workpiece-specific gripper fingers
- ▶ Compact dimensions minimize interfering contours

Features

- ▶ Drive type: pneumatic
- ▶ Kinematics: inclined plane / wedge-hook
- ▶ Working principle: double-acting
- ▶ Options: extensive range of sensors for a variety of polling functions as well as position monitoring



GSP-P – Large-stroke parallel gripper

Advantages

- ▶ High moment load capability
- ▶ For long gripper fingers
- ▶ Round guides protected against contamination
- ▶ Jaws equipped with centering sleeves for adaptation to workpiece-specific gripper fingers

Features

- ▶ Drive type: pneumatic
- ▶ Kinematics: rack and pinion
- ▶ Guide: round guides
- ▶ Working principle: double-acting

- ▶ Options: extensive range of sensors for a variety of polling functions as well as position monitoring



GSP-P – Heavy duty parallel gripper

Advantages

- ▶ With/without gripping force retention
- ▶ Robust, ground T-slot sliding guides for synchronized gripping
- ▶ Suitable for high gripping forces and moment loads

Features

- ▶ Drive type: pneumatic
- ▶ Kinematics: rack and pinion
- ▶ Guide: sliding guides
- ▶ Working principle: double-acting; double-acting, pressureless when closed; double-acting, pressureless when open

- ▶ Options: extensive range of sensors for a variety of polling functions as well as position monitoring

	Multipurpose grippers *				Large-stroke and heavy-duty grippers *	
	GSP-A	GSP-P	GSP-R	GSP-Z	GSP-P	GSP-P
Design	Angular gripper	Parallel gripper	Radial gripper	Centric gripper	Parallel gripper	Parallel gripper
Sizes	5	6	5	3	2	2
Max. closing force (6 bar)	N	–	1,178	–	1,320	1,760
Max. opening force (6 bar)	N	–	1,090	–	1,140	1,760
Max. closing torque (6 bar)	Nm	8.6	–	12	–	–
Stroke per gripper finger	mm	–	2 to 13	–	3 to 7	28 to 64
Opening angle per gripper finger	°	20	–	90	–	–
Repeatability	mm	±0.01	±0.01	±0.01	±0.01	±0.05
Recommended workpiece weight**	kg	0.08 to 0.85	0.13 to 4.2	0.08 to 1.15	0.6 to 5.7	1.6 to 8.8

* The stated maximum values apply to all sizes of that type.

** The recommended workpiece weight for frictional engagement is calculated for force closure with a static friction coefficient of 0.1 and a safety factor of 2 against slipping of the workpiece under the force of gravity g. For positive engagement, the workpiece weights can be significantly higher.

Pneumatic valves

The pneumatic valves of the LS04 series have a very slimline profile of just 10 mm and offer outstanding power density. The XS and AF models are made using advanced, innovative plastics. Thanks to their small size and lightweight design, these valves can be mounted directly on moved parts, thus meeting handling technology demands for weight reduction and fast response.

LS04-XS

Despite its neat size, the maintenance-free compact valve LS04-XS covers all modern valve technology requirements for flow rates up to 200 L/min. As a 5/2-way valve it serves the most commonly needed valve requirements and can be operated with lubricated or unlubricated compressed air.

- ▶ Compressed air connection: integrated plug connector for 4 mm hose diameter
- ▶ Electrical connections: M8 (3-pin, IP65) or standard plug (IP50)
- ▶ Operating voltage: 24 VDC
- ▶ Switching time: 9 ms / 24 ms
- ▶ Dimensions: 57.7 x 10.8 x 44.7 mm
- ▶ Weight: 30 g
- ▶ Status display: LED
- ▶ Manual override: detent, jogging
- ▶ Mounting: metal-reinforced fastening points



LS04-AF

The standard valve LS04-AF has all the basic system characteristics of the LS04-XS, but offers a higher nominal flow rate of 330 L/min and the entire range of pneumatic functions as well. In addition to 5/2 and 5/3-way directional functions, it also covers all double 3/2-way needs.

- ▶ Compressed air connection: integrated plug connector for 4 and 6 mm hose diameters
- ▶ Electrical connections: M8 (3-pin, IP65) or standard plug (IP50)
- ▶ Operating voltage: 24 VDC
- ▶ Switching time: 12 ms / 30 ms
- ▶ Dimensions: 76.2 x 10.8 x 60 mm
- ▶ Weight: 51 g
- ▶ Status display: LED
- ▶ Manual override: detent, jogging
- ▶ Mounting: metal-reinforced fastening points



Vacuum technology

Rexroth's vacuum technology offers everything you need for safe and gentle handling of delicate or soft workpieces. The compact and powerful ejectors for vacuum generation can be installed directly in the hoses or close to the suction grippers. The extensive range of flat and bellows-type suction grippers, which come in a variety of sizes, shapes, materials and surface finishes, and the non-contacting transport unit NCT ensure that each workpiece can be safely transported.



EBS

The wear- and maintenance-free ejectors of the EBS series work on the Venturi principle, generating a vacuum with the help of a compressed air flow. EBS-PI ejectors are extremely compact inline models which have an axial compressed air and vacuum connection. They are designed for direct integration into the vacuum line. The compact ejectors EBS-PT and -ET combine several functions – e.g. vacuum generator, control valve, filter, switches – into one unit which can be mounted directly alongside the suction gripper.

- ▶ Suction capacity: 7 to 223 L/min
- ▶ Compressed air connection: plug connector for 4 to 8 mm hose diameter
- ▶ Optimal operating pressure: 4.5 to 5.4 bar.



FSx, BSx

To serve all the many requirements in handling in the best way possible, Rexroth offers a comprehensive spectrum of suction grippers in different designs and sizes. Flat suction grippers FSx are available in round or oval shapes, while the bellows-type BSx models have 1.5 to 2.5 folds. With diameters and sizes ranging from 1 to 300 mm, there is a model for every kind of application. The following materials are available:

- ▶ Acrylonitrile butadiene rubber (NBR)
- ▶ Fluoromethyl polysiloxane (silicon)
- ▶ Polyurethane (Vulkollan®)
- ▶ Chloroprene rubber (CR)
- ▶ Hydrogenated acrylonitrile butadiene rubber (HNBR)

NCT

The NCT from Rexroth allows you to gently lift and move porous or air-permeable objects as well as soft material or very delicate workpieces. Working on the Bernoulli principle, it transports workpieces with no surface contact. Aluminum versions are available, as well as polyether ether ketone (PEEK) versions for transporting food or silicon, in diameters up to 60 mm and with holding forces of up to 12 N.

Servo motors, linear motors

Rexroth's IndraDyn range offers you a comprehensive selection of motors that deliver convincing performance, no matter which of the many designs, versions, options and ratings you choose. The broad portfolio of compact rotary synchronous servo motors MSK and MSM satisfies all requirements in terms of dynamics, torque and speed. Ironless synchronous linear motors of the MCL series excel with their exceptionally high synchronization accuracy at maximum acceleration and force.

MSK

The MSK range of servo motors has an especially wide power spectrum with narrow size increments. The high torque density of these synchronous servo motors allows a particularly compact design with high torques.

- ▶ Maximum torque up to 43.5 Nm
- ▶ Maximum speed up to 9,000 min⁻¹
- ▶ Multiturn Hiperface® encoder with 128 increments
- ▶ Plain shaft with shaft seal ring
- ▶ Protection class IP65
- ▶ Electrically released holding brake (optional)



MSM

Maintenance-free MSM synchronous servo motors are available in different ratings. Thanks to their high power density combined with short length and minimal flange size they are ideal for use in a wide variety of high-dynamic applications in the most varied of process environments.

- ▶ Maximum torque up to 7.1 Nm
- ▶ Maximum speed up to 5,000 min⁻¹
- ▶ Multiturn absolute encoder
- ▶ Plain shaft without shaft seal ring
- ▶ Protection class IP54
- ▶ Electrically released holding brake (optional)



MCL

Ironless MCL linear motors come in graded lengths and sizes. Their compact design with different mounting planes provides exceptional flexibility for system construction. The U-shaped secondary part contains permanent magnets and encloses the primary component. This design ensures that there will be no attraction or cogging force between the primary and secondary part and the force constant will remain linear. Unlike other types of construction, there is no additional load on the linear guides. Integrated Hall sensors assure highest precision.

- ▶ Maximum force up to 1,712 N
- ▶ Maximum speed up to 1,400 m/min
- ▶ Excellent synchronism, no cogging forces
- ▶ Low intrinsic weight, high acceleration and dynamics
- ▶ Easy integration thanks to different mounting planes

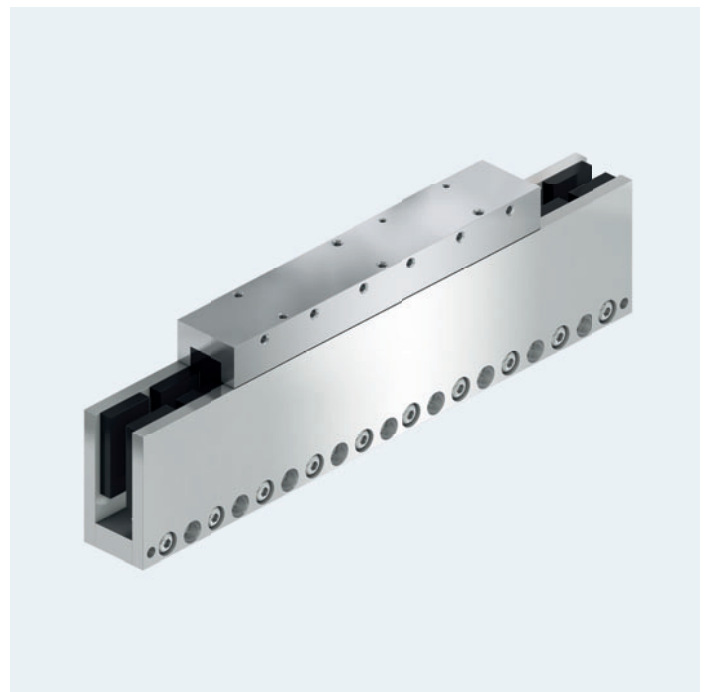

Motor *	MSK	MSM	MCL
Design type	Rotary synchronous servo motor	Rotary synchronous servo motor	Linear synchronous servo motor
Sizes/increments	6/22	3/5	4/26
Standstill torque	0.4 to 12 Nm	0.16 to 2.4 Nm	–
Max. continuous rated force	–	–	26 to 428 N
Max. torque	43.5 Nm	7.1 Nm	–
Max. force	–	–	1,712 N
Max. rotary speed	9,000 min ⁻¹	5,000 min ⁻¹	–
Max. linear speed	–	–	1,400 m/min
Measuring system	Optical, absolute multturn encoder ▶ Hiperface® ▶ EnDat	Optical absolute multturn encoder	Customer preference
Protection class	IP65	IP54	Customer preference
Options	With/without holding brake	With/without holding brake	Analog/digital Hall sensors

* The stated maximum values apply to all sizes of that type.

Compact electric drives

IndraDrive Cs electric drives stand out especially for their space-saving design, excellent performance data and finely-graded size increments. Since they also have outstanding control loop characteristics, they are ideal for mechatronic handling applications. With their broad range of Ethernet-based interface options for control communication and their multi-encoder interface, they offer the greatest possible flexibility and open architecture capability. The IndraDrive Cs can, of course, also be equipped with a conventional communication interface such as PROFIBUS.

HCS01 – Features

- ▶ 3 series for direct mains connection to 110 - 230 VAC or 200 - 500 VAC
- ▶ Suitable for motors with a continuous power rating of 0.05 to 9 kW
- ▶ Unit depth < 300 mm
- ▶ Smart operating panel with programming module function (hot plug capable)
- ▶ DC bus coupling possible
- ▶ Power-dependent fan control
- ▶ Brake resistor integrated in heat sink (external resistor possible)
- ▶ Protection class IP20

Interfaces

- ▶ Ethernet-based protocols: sercos III, PROFINET IO, EtherNet/IP, EtherCat
- ▶ Field buses: PROFIBUS DP, CANopen
- ▶ Multi-encoder interface: absolute encoder (EnDat 2.1, Hiperface®, Rexroth MSM motors), incremental encoder (1 V_{pp}, 5 V TTL), SSI encoder, resolver, combination encoder (1 V_{pp} + Hall sensor, TTL + Hall sensor)
- ▶ Encoder emulation
- ▶ On-board digital inputs/outputs and analog input
- ▶ Cross-communication: sercos III

Operating modes

- ▶ Torque control
- ▶ Force control
- ▶ Speed control
- ▶ Position control
- ▶ Drive-internal interpolation
- ▶ Drive-controlled positioning
- ▶ Position block mode

Safety functions

(Category 4, PL e as per EN ISO 13849-1 and SIL 3 as per EN 62061)

- ▶ STO – Safe Torque Off
- ▶ SBC – Safe Brake Control

Protection functions

- ▶ Motor temperature monitoring
- ▶ Torque monitoring
- ▶ Lag error monitoring
- ▶ Low-voltage monitoring
- ▶ Soft limit switches



Compensation functions

- ▶ Frictional torque compensation
- ▶ Axis error correction
- ▶ Quadrant error correction
- ▶ Cogging torque compensation
- ▶ Correction of torque/force constant

Control functions

- ▶ Runtime system compliant with IEC 61131-3
- ▶ Program organization per IEC 61131-3
- ▶ Programming languages: FBD, ST, IL, LD, SFC, CFC
- ▶ 8 freely programmable tasks (cyclic, free running, event-controlled, externally event-controlled)
- ▶ Motion control functions for handling and positioning tasks via PLCopen function blocks

Version		ECONOMY	BASIC UNIVERSAL	ADVANCED
Ethernet-based interfaces		sercos III	sercos III PROFINET IO EtherNet/IP EtherCat	sercos III PROFINET IO EtherNet/IP EtherCat
Field buses	Option	–	PROFIBUS DP CANopen	PROFIBUS DP CANopen
Cross-communication	Option	–	sercos III	sercos III
I/O interfaces		Digital 7I/1IO Analog 1I	Digital 7I/1IO Analog 1I	Digital 7I/1IO Analog 1I
Multi-encoder interface		EnDat 02.1 Hiperface® MSM motor encoder 1 V _{pp} 5 V TTL SSI Resolver	EnDat 02.1 Hiperface® MSM motor encoder 1 V _{pp} 5 V TTL SSI Resolver Combination encoder (1 V _{pp} + Hall sensor) Combination encoder (TTL + Hall sensor)	EnDat 02.1 Hiperface® MSM motor encoder 1 V _{pp} 5 V TTL SSI Resolver Combination encoder (1 V _{pp} + Hall sensor) Combination encoder (TTL + Hall sensor)
Encoder emulation	Option	–	Yes	Yes
Safety functions	Option	STO SBC	STO SBC	STO SBC
Integrated motion logic	Option	–	Single axis	Single axis Multi-axis

Performance data	Mains supply voltage [V]	Size	Dimensions H x W x D [mm]	Continuous current [A _{eff}]	Maximum current [A _{eff}]	DC bus continuous power without/with mains choke [kW]
HCS01.1E-W0003-A-02	3 AC 110 ... 230 V ¹⁾	1	215 x 50 x 220	1.4	3.3	0.15 / –
HCS01.1E-W0006-A-02				2.4	6.0	0.25 / –
HCS01.1E-W0009-A-02				3.0	9.0	0.46 / –
HCS01.1E-W0013-A-02				4.4	13.0	0.80 / –
HCS01.1E-W0018-A-02				7.6	18.0	1.80 / –
HCS01.1E-W0005-A-03	3 AC 200 ... 500 V	1	215 x 50 x 220	2.0	5.0	0.46 / –
HCS01.1E-W0008-A-03				2.7	8.0	0.86 / –
HCS01.1E-W0018-A-03				7.6	18.0	1.70 / –
HCS01.1E-W0028-A-03				11.5	28.0	2.60 / 4.00
HCS01.1E-W0054-A-03				21.0	54.0	9.00 / 14.00

¹⁾ Single-phase operation possible, derating in the case of HCS01.1E-W0013 and -W0018.

Compact controls

The controller-based IndraControl L control platform from Rexroth is distinguished by its open communication capability, compact design and its range of options and add-ons. The core unit with terminals is simply mounted on a top-hat rail without the need for tools. Add-on function modules, I/O modules and a choice of different communication interfaces allow the controls to be adapted to match each specific application.



CML 25

- ▶ Interfaces: Ethernet TCP/IP (for link-up to HMI, engineering and master computers)
- ▶ Field buses: sercos III (for integration of drives and distributed I/O modules)
- ▶ I/O: local I/O expansion of controls with up to 63 add-on I/O modules
- ▶ Function modules: max. 2 (for communication and technology expansion)
- ▶ Slot: CompactFlash
- ▶ Protection class: IP20
- ▶ Mounting: top-hat rail



CML 45

- ▶ Interfaces: Ethernet TCP/IP (for link-up to HMI, engineering and master computers)
- ▶ Field buses: sercos III, PROFINET IO, EtherNet/IP, PROFIBUS (for integration of drives and distributed I/O modules)
- ▶ I/O:
 - on-board I/O (8 inputs, 8 outputs)
 - local I/O expansion of controls with up to 63 add-on I/O modules
- ▶ Function modules: max. 4 (for communication and technology expansion)
- ▶ Slot: CompactFlash
- ▶ Protection class: IP20
- ▶ Mounting: top-hat rail

Control unit		CML25	CML45
Hardware			
Processor		SH4-compatible	x86-compatible
Memory	Application	128 MB	256 MB
	Flash	1 GB	1 GB
Interfaces	Standard	Ethernet TCP/IP, "Ready" contact	Ethernet TCP/IP, "Ready" contact
Field buses	Standard	-	PROFIBUS DP
	Optional	sercos III	sercos III, PROFINET IO, EtherNet/IP
I/O	On board	-	8E/8A
	Local add-on	Max. 63 IP20 I/O modules	Max. 63 IP20 I/O modules
	Distributed	Via field bus	Via field bus
Function modules	Local add-on	Max. 2	Max. 4
Dimensions	H x W x D	120 x 175 x 76 mm	120 x 175 x 97.5 mm
Functions			
Program organization		IEC 61131-3	IEC 61131-3
Programming languages		FBD, ST, IL, LD, SFC, CFC	FBD, ST, IL, LD, SFC, CFC
Tasks	Cyclic, free running, event-controlled, externally event-controlled	8 freely programmable	8 freely programmable

I/O technology

Rexroth I/O technology ensures reliable and safe integration of sensors and actuators, no matter where they are located – locally in a control cabinet or distributed. The I/O modules in IP20 protection class are available with different functions and scalability. They can be added on directly to the control unit or grouped into separate I/O stations and linked up via a bus coupler. IP20 block I/O stations with fixed configurations are also available as an alternative. The I/O modules in IP67 are ideal for signal recording near machines, even under extreme environmental conditions. With their high IP65 protection class, the modular pneumatic valve systems can be installed close to the application as well as in the control cabinet.



R-IL/R-IB

This modular I/O technology in IP20 offers multiple opportunities for customized signal processing. The modules can be added on directly to CML control units or grouped into separate I/O stations and linked up via a bus coupler.

In addition to digital and analog I/O modules, there are communication, temperature and function modules, e.g. for pulse width modulation.

- ▶ Bus coupler: sercos III, PROFINET IO, PROFIBUS DP
- ▶ Digital I/O modules
- ▶ Analog I/O modules
- ▶ Communication modules
- ▶ Function modules
- ▶ Temperature modules
- ▶ Power supply/segment modules
- ▶ Relay modules

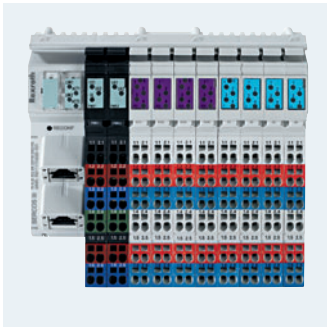

R-ILB

The fixed-configuration block I/O modules with IP20 protection are ideal for applications with low-complexity I/O needs. The integrated bus coupler is compatible with all common types of field bus, and the modules come with either digital or analog I/Os for signal processing.

With their compact construction, these block modules are ideal for installation in small control cabinets.

- ▶ Bus coupler: sercos III, PROFINET IO, PROFIBUS DP
- ▶ Digital I/Os
- ▶ Analog I/Os



S67

With their high degree of protection – IP67 – these I/O modules can be installed in harsh industrial environments. Up to 64 I/O modules can be operated through one fieldbus coupler.

Other convenient features are fast, simple installation, a choice of fieldbus options, and M12 and M8 connection technology.

- ▶ Bus coupler: PROFINET IO, PROFIBUS
- ▶ Digital I/O modules
- ▶ Analog I/O modules
- ▶ Power supply modules



HF04

The powerful valve systems of the HF04 series with IP65 protection have nominal flow rates of up to 400 L/min. Their modular design accommodating up to 32 valves allows easy system expansion.

If modifications are required or a valve needs to be replaced, this can be done easily without having to de-install the entire system thanks to the base-plate design principle. Various bus systems are available for linking up the systems to the controls.

- ▶ Functions: double 3/2-way directional valve, bi- and monostable 5/2 directional valve with closed or open neutral position
- ▶ Bus systems: sercos III, PROFINET IO, EtherNet/IP, EtherCat, PROFIBUS DP, CANopen, DeviceNet, DDL
- ▶ Options: integrated pressure regulators, rotary fittings

Visualization

Rexroth's IndraControl V range offers you a comprehensive HMI device portfolio for customized visualization, operator control and monitoring. The scalable program ranges from controller-based compact operator terminals and ergonomic handheld devices to highly integrated embedded PCs. The VCP compact operator terminals with keypad or touchscreen input allow you to change production data easily directly at the machine. For frequent changes in setup, the handheld VCH operator panel is the perfect choice. Its optimized ergonomics, integrated handwheels and accept and stop keys are designed to ensure reliable, fatigue-free handling. The highly integrated embedded PCs of the VEP series are especially suited for visualization of complex multi-axis applications.



VCP 08

- ▶ Display: 3.8" (9.7 cm), 320 x 240, FSTN, 5 gray tones
- ▶ Processor: 200 MHz
- ▶ Memory: 3 MB (application), 16 MB (flash)
- ▶ Operation: 15 function keys, 24 system keys
- ▶ Communication: Ethernet TCP/IP, 2 x USB 2.0
- ▶ Protection class: IP65 (front)
- ▶ Dimensions: 205x155x55 mm (H x W x D)



VCP 11

- ▶ Display: 3.5" (8.5 cm), 320 x 240, TFT, 256 colors
- ▶ Processor: 200 MHz
- ▶ Memory: 3 MB (application), 16 MB (flash)
- ▶ Operation: touchscreen
- ▶ Communication: Ethernet TCP/IP, 2 x USB 2.0
- ▶ Protection class: IP65 (front)
- ▶ Dimensions: 130x96x58 mm (H x W x D)



VCH 08

- ▶ Display: 3.8" (9.7 cm), 320 x 240, FSTN, 5 gray tones
- ▶ Processor: 416 MHz
- ▶ Memory: 64 MB (application), 64 MB (flash)
- ▶ Operation: 15 function keys, 25 system keys, 2 accept keys (2-circuit, 3-step), stop key (2-circuit), handwheel, override potentiometer
- ▶ Communication: Ethernet TCP/IP (via junction box VAC)
- ▶ Protection class: IP65
- ▶ Dimensions: Ø 250x55 mm + 37 mm handle
- ▶ Weight: 1.1 kg
- ▶ Connecting cable: 8 m

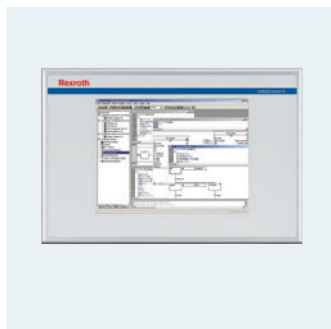

VEP 30

- ▶ Display: 8.4" (21.3 cm), 800 x 600, SVGA, 262,144 colors
- ▶ Processor: Intel Ultra Low Voltage Celeron 600 MHz
- ▶ Memory: 512 MB (application), min. 128 MB (flash, 2 x CompactFlash card)
- ▶ Operation: touchscreen (virtual keyboard)
- ▶ Communication: Ethernet TCP/IP, 2 x USB 2.0, RS232
- ▶ Protection class: IP65 (front)
- ▶ Dimensions: 200x296x75 mm (H x W x D)

Further components and systems

Beyond EasyHandling, Rexroth also provides everything else you need for smart automation and linking of all your machines and production processes.

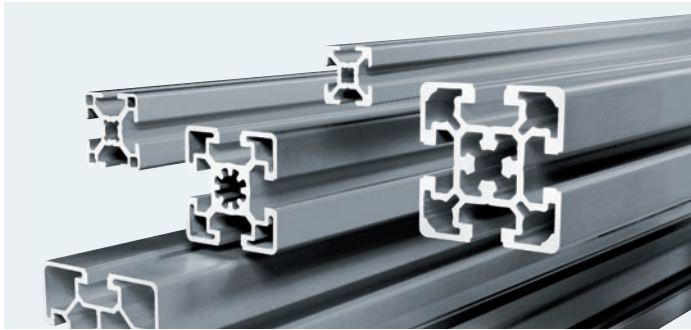

Basic mechanical elements

With well over 100 different strut profiles, Rexroth offers you the world's most comprehensive framing system for basic constructions such as racks, enclosures, workbenches or protective barriers. Lightweight, well designed aluminum components reduce the planning and assembly cost and effort and can be easily re-used or re-configured.

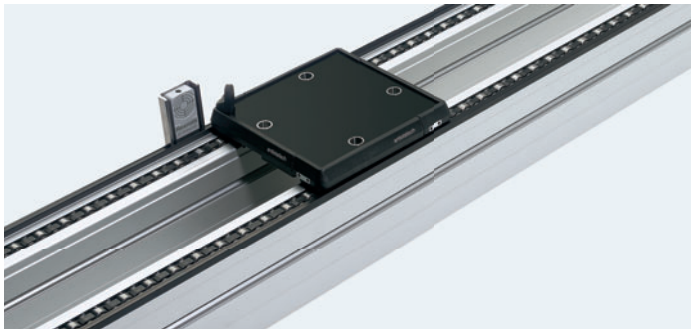

Transfer systems with integrated identification systems

Rexroth dual belt and accumulation roller systems can handle weights from a few grams up to 300 kg. Identification systems recognize and store object-related data, thus assuring optimally managed production and conveying processes.



Powerful chain conveyor systems

Chain conveyor systems from Rexroth achieve a tensile force of up to 1,250 N and can be very easily adapted to specific tasks. Furthermore, they are among the most economical solutions on the market in terms of purchase price and operating costs.



Innovative tightening systems

Compact, precise and reliable – the innovative tightening control systems with integrated logics, high-performance tightening spindles and ergonomic handheld nutrunners fulfill every task with top quality results.

Engineering



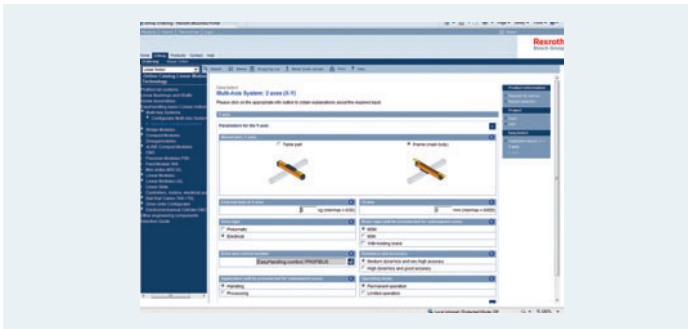

- 52 **Engineering**
- 54 Project planning
- 55 Mounting
- 56 Parameter input
- 58 Programming

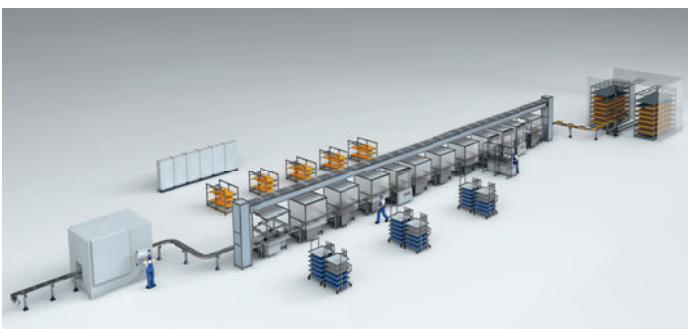
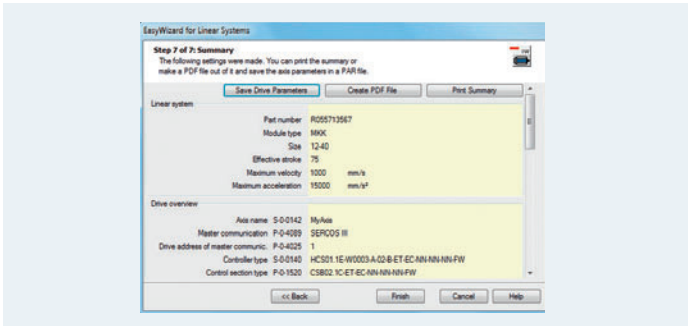
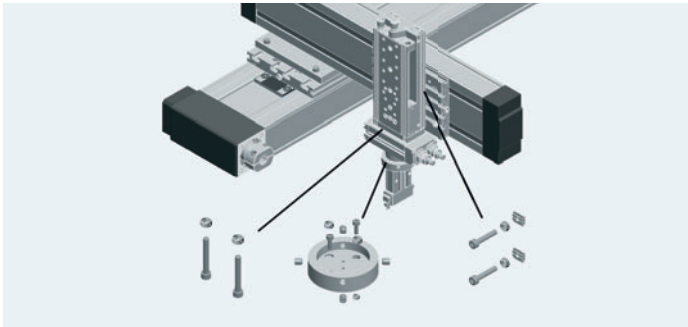

Project planning

EasySelect

EasySelect is the online selection guide for easy and rapid generation of a virtual single-axis or multi-axis system. All you need to do is to enter a few key parameters such as geometry, workpiece weight, stroke and dynamics, and the system will output a solution proposal together with a parts list.

► www.boschrexroth.com/easyselect

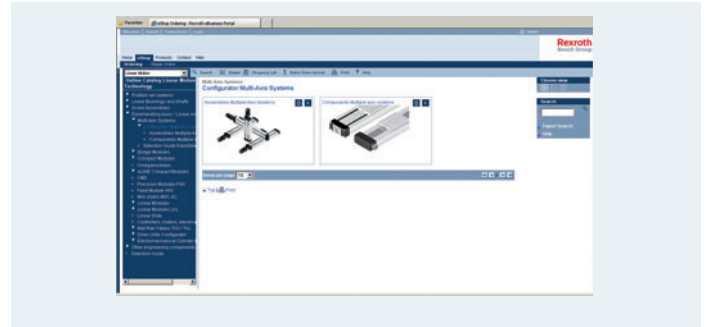

CAD Configurator

At the end of the EasySelect procedure you can switch by mouse-click to the Rexroth CAD Configurator for single- and multi-axis systems. Here you will find a CAD model of the solution proposal you generated, which you can then adapt and modify as required. To generate your own custom model, you can also go directly to the CAD Configurator. The results can be generated as downloadable 2D or 3D CAD files in common formats as a basis for requesting consultation or designing your machine.

► www.boschrexroth.com/easycad



The CAD data for individual Rexroth products are also available for download from our online catalog.

► www.boschrexroth.com/technologies

IndraSize

The convenient IndraSize program for drive sizing is the quick and easy way to find the best drive for your handling system. No matter whether you are looking for a conventional servo axis or a direct drive, you can define the ideal motor-controller combination in just a few steps. The program allows you to generate a complete motion profile yourself by inputting individual motion sequences, or you can use a pre-defined, optimized travel profile.

► www.boschrexroth.com/indrasize

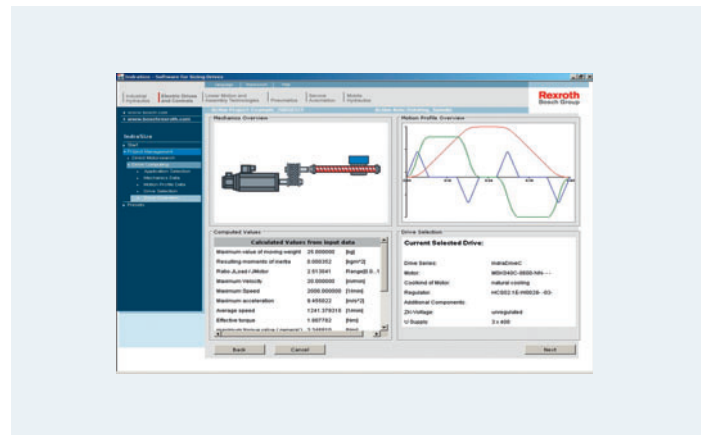

Mounting

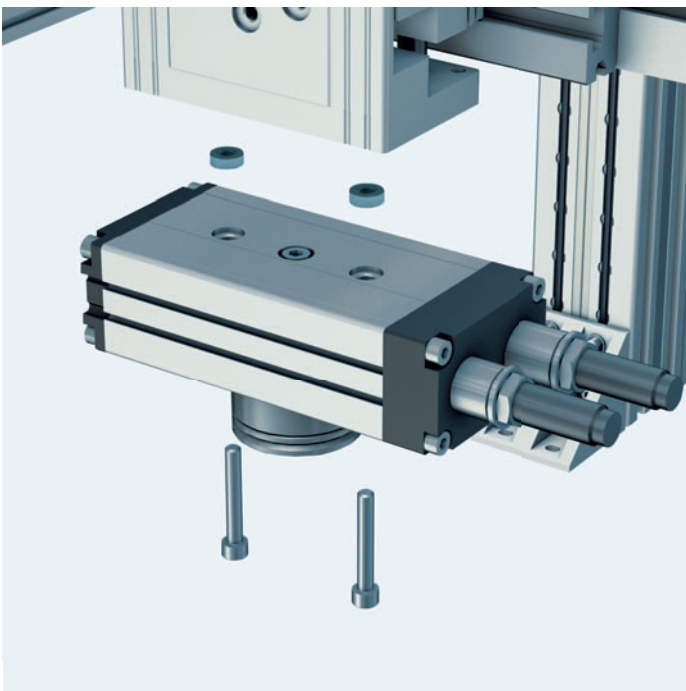
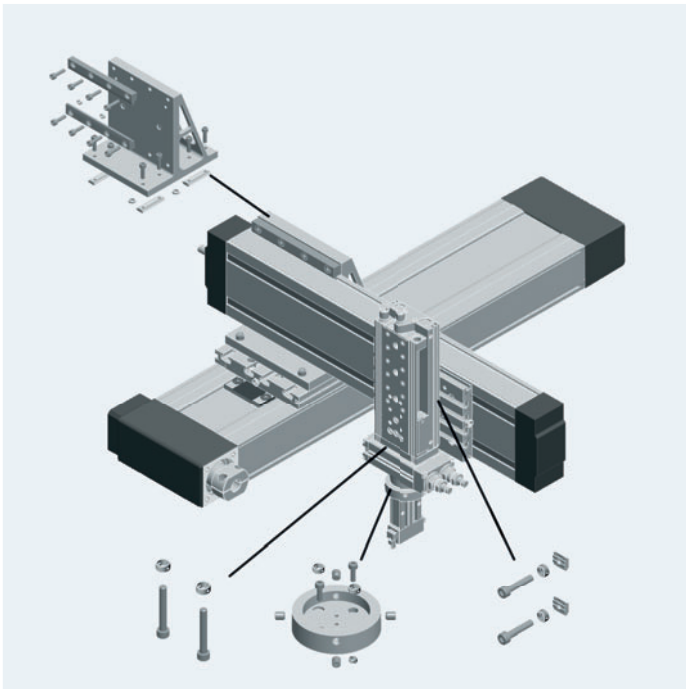

Form-fit connection technology for easy mounting

EasyHandling reduces your effort significantly at the installation stage as well. The mechanical and pneumatic modules have positive-locking Easy-2-Combine interfaces. With this innovative locating and centering technology, all components are perfectly aligned and accurately connected right away, making it unnecessary to build expensive custom-designed constructions.

Rexroth offers an extensive range of connecting elements – brackets, adapter plates, clamping fixtures, sliding blocks, T-nuts, etc. – designed to meet all handling application needs.

Advantages

- ▶ Direct connection without intermediate plates results in high structural integrity, minimal space requirement, minimal weight and high dynamics
- ▶ Standardized, positive-locking connection elements
- ▶ Easy to install
- ▶ Easy reproducibility
- ▶ Standardization through fixed dimensional increments
- ▶ Reduced parts complexity thanks to multiple combination options using the same connection kit
- ▶ Endless combination possibilities

More information on connection technology can be found in Rexroth's media directory. Simply search for document number R310EN2606.

- ▶ www.boschrexroth.com/mediadirectory

Parameter input

Easy start-up thanks to integrated assistant

EasyWizard is an assistant that is integrated as a standard feature of Rexroth's engineering framework IndraWorks DS. It was designed to help users start-up linear systems easily, rapidly and safely. Starting up electromechanical axes often used to be a complicated, time-consuming and error-prone procedure. EasyWizard has changed all that – preconfigured data sets and component nameplates designed to dovetail with the assistant take the hassle out of getting your linear systems up and running.

Advantages

- ▶ Fast, simple and intuitive start-up
- ▶ Online help texts and supporting graphics guide you through the input fields
- ▶ Plausibility checks for free data input
- ▶ Suitable for all Rexroth linear systems
- ▶ Parameter input errors are minimized by having the data on the nameplate and in the Wizard input mask arranged in a similar order.
- ▶ For system optimization after parameter input, the axis can be run in the test mode.

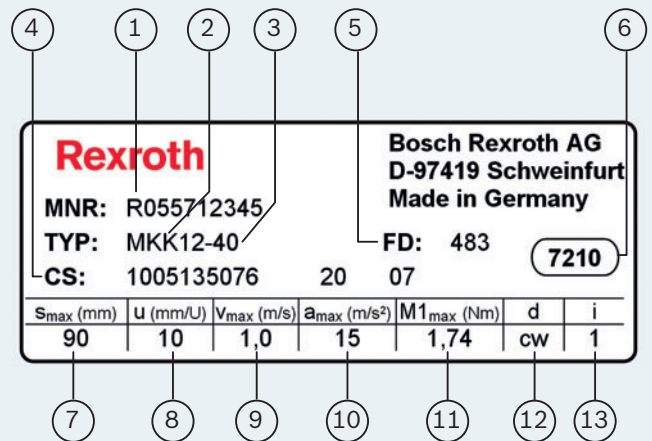

- 1 Part number
- 2 Type designation
- 3 Size
- 4 Customer information
- 5 Date of manufacture
- 6 Manufacturing location
- 7 s_{\max} – max. travel range [mm]
- 8 u – feed/lead constant without gear unit [mm/rev]
- 9 v_{\max} – max. linear speed without gear unit [m/s]
- 10 a_{\max} – max. acceleration without gear unit [m/s²]
- 11 $M1_{\max}$ – max. drive torque at motor journal [Nm]
- 12 d – motor torque for travel in positive direction
- 13 i – gear ratio

Starting up an axis in just six steps:

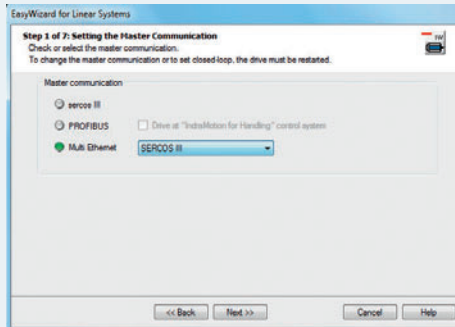

- 1. Define the communication interface

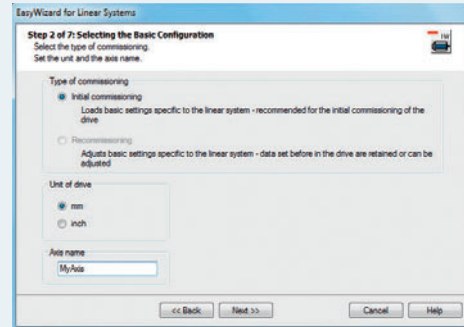

- 2. Select the basic configuration

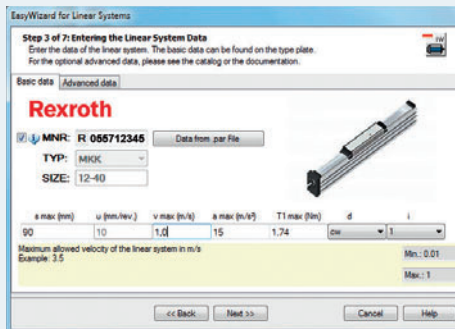

- 3. Enter mechanical data

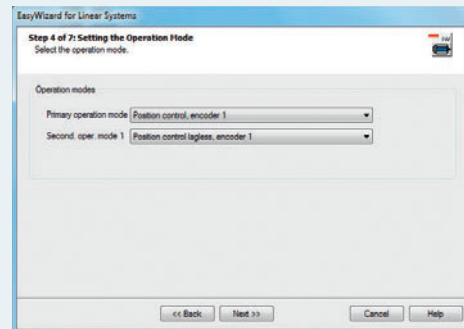

- 4. Select the operating mode

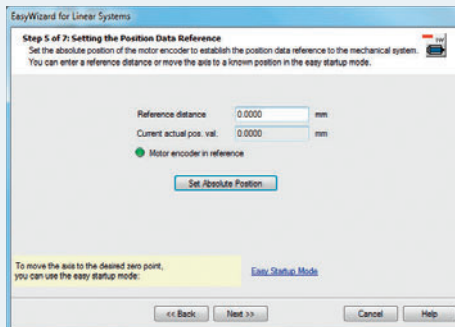

- 5. Set the reference dimension

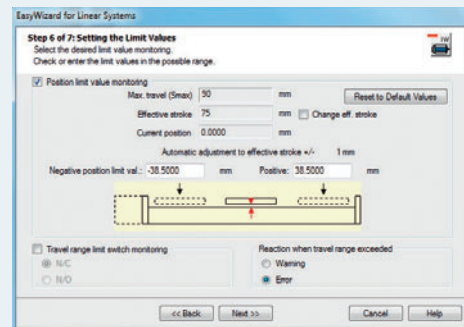

- 6. Set the limit values

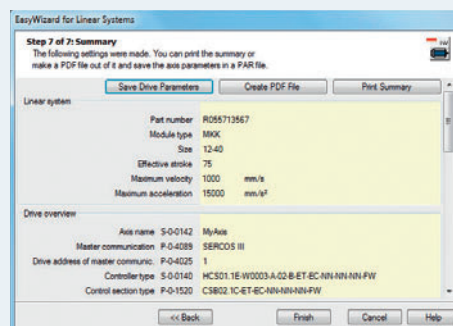

Summary of your data settings with save and print options.

Programming

Pre-defined program modules simplify application programming

IndraMotion for Handling is a preconfigured, open motion logic solution for drive and controller based handling applications. With its predefined program code it covers almost all applications and replaces time-consuming programming with rapid configuration. All functionalities for efficient coordination of axis movements are provided:

- ▶ Defined PLC libraries and basic program structures for motion programming and visualization
- ▶ Multi-kinematics function for controlling up to 4 kinematic configurations with one control system and up to 6 axes per configuration
- ▶ Time-optimized point-to-point motion, path-optimized linear travel and blended motion
- ▶ Master/slave axes in gantries
- ▶ Reliable monitoring of axes using soft limit switches
- ▶ 4 freely definable protective zones
- ▶ Recording and visualizing mileage and duty cycles and necessary maintenance intervals
- ▶ Transparent drive diagnostics with clear text messages
- ▶ Ready-made visualization projects

IndraMotion for Handling uses the standard command syntax found in most robotics applications. The number of commands has been minimized. Together with the intuitive input masks, this helps to speed up user familiarization.

Functions

- ▶ Commands for single and multi-axis movements
- ▶ Event-based cancelling of movements
- ▶ Predefining travel speeds and acceleration
- ▶ Direct access to inputs/outputs
- ▶ Switching of outputs during a movement
- ▶ Structuring of motion programs using subroutine technology
- ▶ Comments for greater transparency
- ▶ Integer and real variables
- ▶ Conditional jumps
- ▶ Free adaptation of syntax, point names and input/output names
- ▶ Incremental and continuous jogging of axes
- ▶ Easy teach-in and programming using handheld devices
- ▶ Variable speed override

IndraMotion for Handling	Drive-based	Controller-based	Controller-based
Control hardware	HCS01	CML25	CML45
Number of axes			
No. of axes per kinematic configuration	6	6	6
No. of kinematic configurations	1	4	4
HMI device			
VCP 08	0	0	0
VCP 11	0	0	0
VCH 08	0	0	0
VEP 30	-	0	0

0 = Option - = Not possible

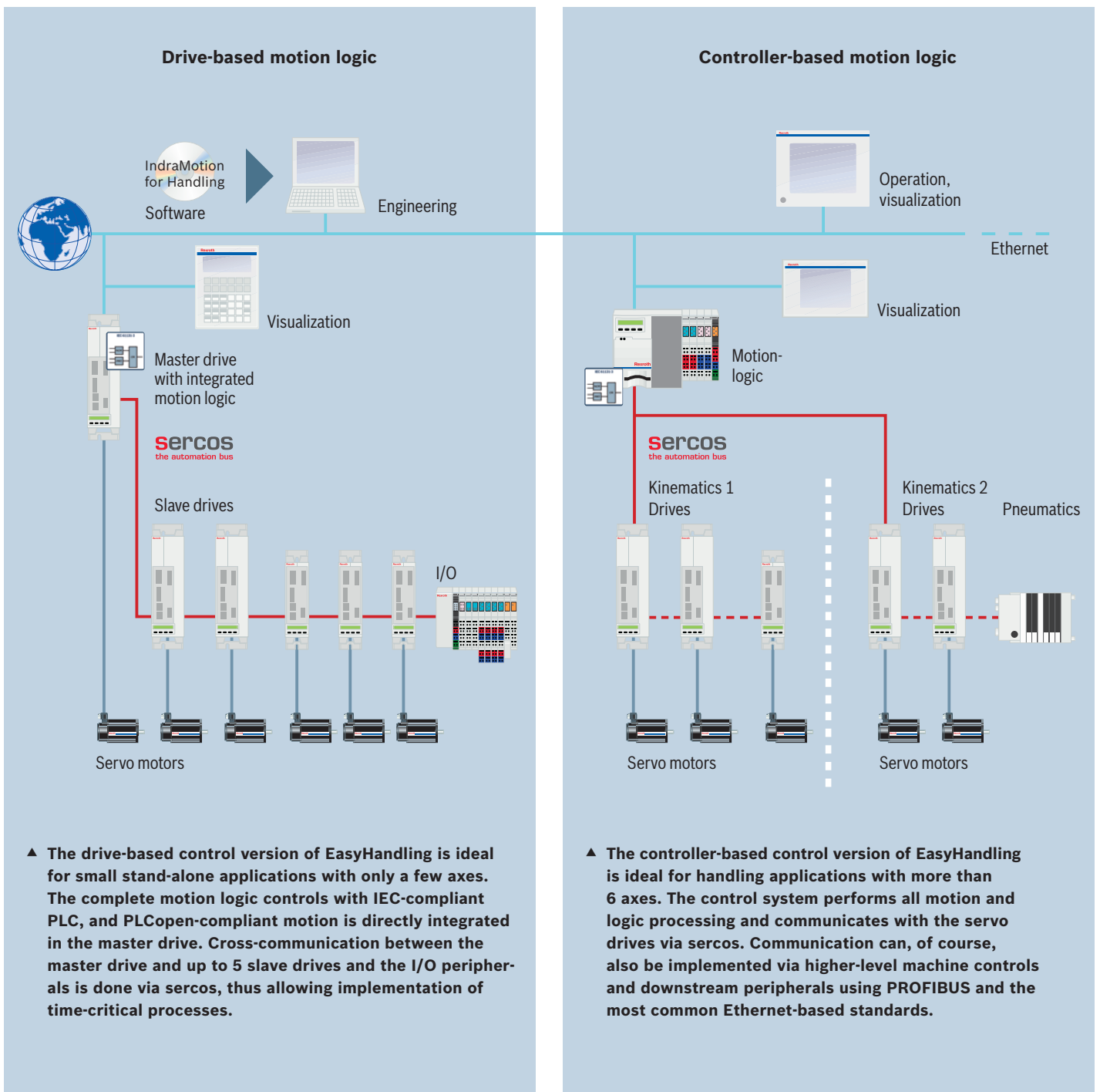

Services





60	Services
62	Consulting
64	Training
66	Technical customer service

Consulting

Rexroth offers you extensive project planning and application support as early as the engineering and design phase. Our experts operate internationally, specialize in specific industries and are familiar with local needs. You can depend on them to provide first-class advice on every aspect of your new project – across all technologies.



For more information, visit:

www.boschrexroth.com/contact



Application consulting

Together with you, we determine the solution approaches and concepts that will allow you to implement your plans with the highest degree of process reliability and flexibility.

- ▶ Identifying typical customer-specific applications
- ▶ Selecting and proposing suitable combinations of automation components for specific projects
- ▶ Specifying and providing mechanical and electrical interfaces

Technical documentation

Detailed descriptions and manuals for the drive, control and motion technology used.

**Energy efficiency consulting**

Rexroth's energy efficiency experts analyze production processes and systems from start to finish. In addition to optimizing details, they look at the overall facility, developing all-encompassing strategies and accompanying you from the initial analysis through to implementation. Our uniquely systematic 4EE approach enables us to consider all technologies when identifying opportunities to improve energy efficiency.

CAD support

We supply complete CAD models, from standard components through to customer-specific multi-axis systems. This enables you to simplify your development and design processes and get results faster.

Training

Rexroth offers a wide-ranging training and education program with a practical focus that covers all drive, control and motion technologies. The main emphasis lies on integrating specialized knowledge from different disciplines and conveying it in the most appropriate way to audiences with different needs, such as customers, our own employees, and educational institutions. Our courses are designed above all for developers and design engineers, machine operators and maintenance personnel at machine manufacturers and industrial users.



For more information, visit:

www.boschrexroth.com/training



Training seminars

By continuously developing new seminars and optimizing existing ones, we keep the content up to date at all times. The program includes personal presence seminars, e-learning, practical training courses, and blended learning, which combines the advantages of personal presence seminars with those of e-learning.



Training systems

Rexroth's training systems give both beginners and advanced users practical insights into hydraulics, pneumatics, electric drives and controls, mechatronics and automation. They are equipped with industrial-grade series components and use internationally standardized programming languages and open interfaces.



Training materials

The software-based teaching and learning materials have high practical relevance. They include e-learning modules, technology and application training tools, component and system animations, and simulation-aided learning units. All of these are supplemented by glossaries, textbooks, manuals and work aids.



Knowledge portal

The newly created multimedia knowledge portal complements our industrial and educational training programs. With a global network contributing to it, this portal offers users high-quality information and opportunities to share knowledge and experience.

Technical customer service

We stay at your side throughout the lifetime of your machine or system. Whether you need assistance during start-up and operation or need advice on how to prolong your machine's life, our local technical service teams will be ready to provide expert support in all respects. By interacting closely with our development and application departments, you gain additional technical insights and the assurance that your systems will perform with utmost reliability.



For more information, visit:

www.boschrexroth.com/service

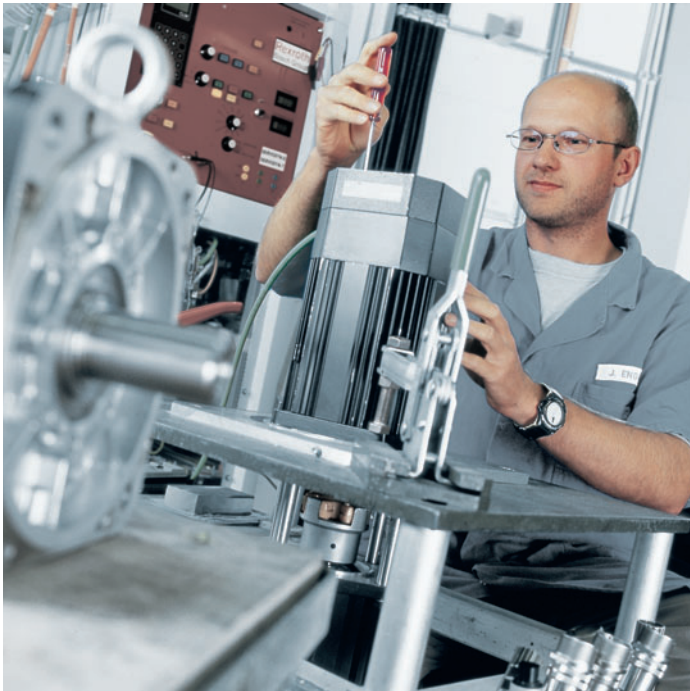

Start-up assistance

- ▶ System start-up according to customer specifications
- ▶ Parameter input and drive optimization
- ▶ Integration into higher-level control systems

Machine safety

- ▶ Line inspections
- ▶ Risk assessment
- ▶ Safety concepts

Helpdesk and hotline

- ▶ Troubleshooting and fault clearance
- ▶ Remote support capability
- ▶ Service hotline for emergencies

Field service

- ▶ On-site support to deal with any application problems, troubleshooting and fault clearance
- ▶ System optimization to prolong equipment life and enhance productivity
- ▶ Maintenance and repair work

Repair service

- ▶ Fast, professional repairs, carried out in accordance with internationally applicable specifications and quality standards
- ▶ Replacement of all wear parts during product overhauls, including warranties for new parts
- ▶ Use of original spare parts

**Spare parts service**

- ▶ 24-hour shipment for standard replacement parts
- ▶ Guaranteed quality due to use of original spare parts
- ▶ Extensive inventory to cover your specific needs

Preventive maintenance

- ▶ Longer machine life
- ▶ Reduction of unplanned downtime
- ▶ Manageable maintenance budget

**Retrofitting and modernization**

- ▶ Cost-effective modernization and modification of machines and systems
- ▶ Capacity increase through installation of state-of-the-art components
- ▶ Adaptation to meet changing legal or environmental requirements

Further information



EasyHandling

To find complete information on EasyHandling, visit www.easy-handling.com



Request for advice/consulting
www.boschrexroth.com/contact



Assembly and handling

For information on Rexroth products and system solutions for assembly and handling, visit www.boschrexroth.com/assembly_handling



Training programs
www.boschrexroth.com/training



Rexroth online

To learn more about Bosch Rexroth AG and our technologies and system solutions, visit www.boschrexroth.com



Technical customer service
www.boschrexroth.com/service

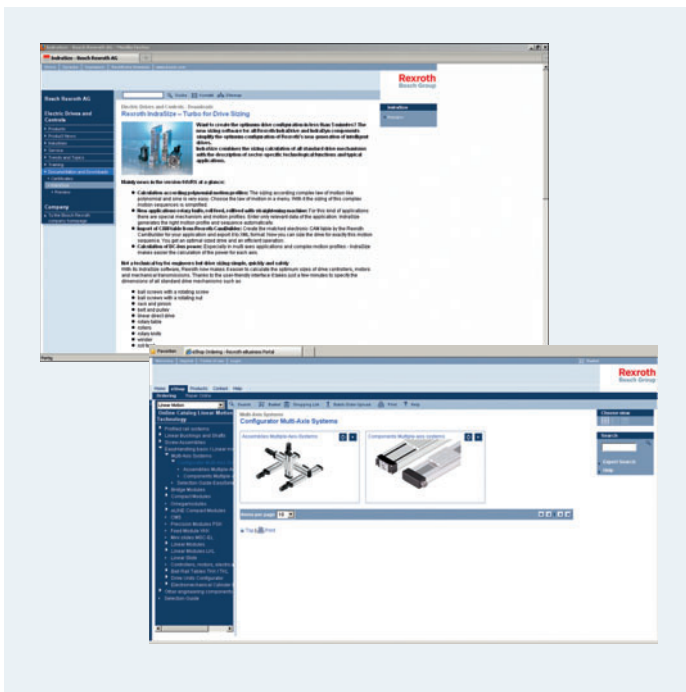

EasySelect

You will find the online selection guide for generating a virtual single-axis or multi-axis system at www.boschrexroth.com/easyselect



Components online

Up-to-date technical data, information and CAD data for all EasyHandling components can be found at www.boschrexroth.com/technologies



CAD Configurator

To find the configurator for generating CAD models of single-axis or multi-axis systems, visit www.boschrexroth.com/easycad



Documentation online

Current documentation on all EasyHandling components is available at www.boschrexroth.com/mediadirectory



IndraSize

This program for dimensioning electric drives can be downloaded from www.boschrexroth.com/indrasize

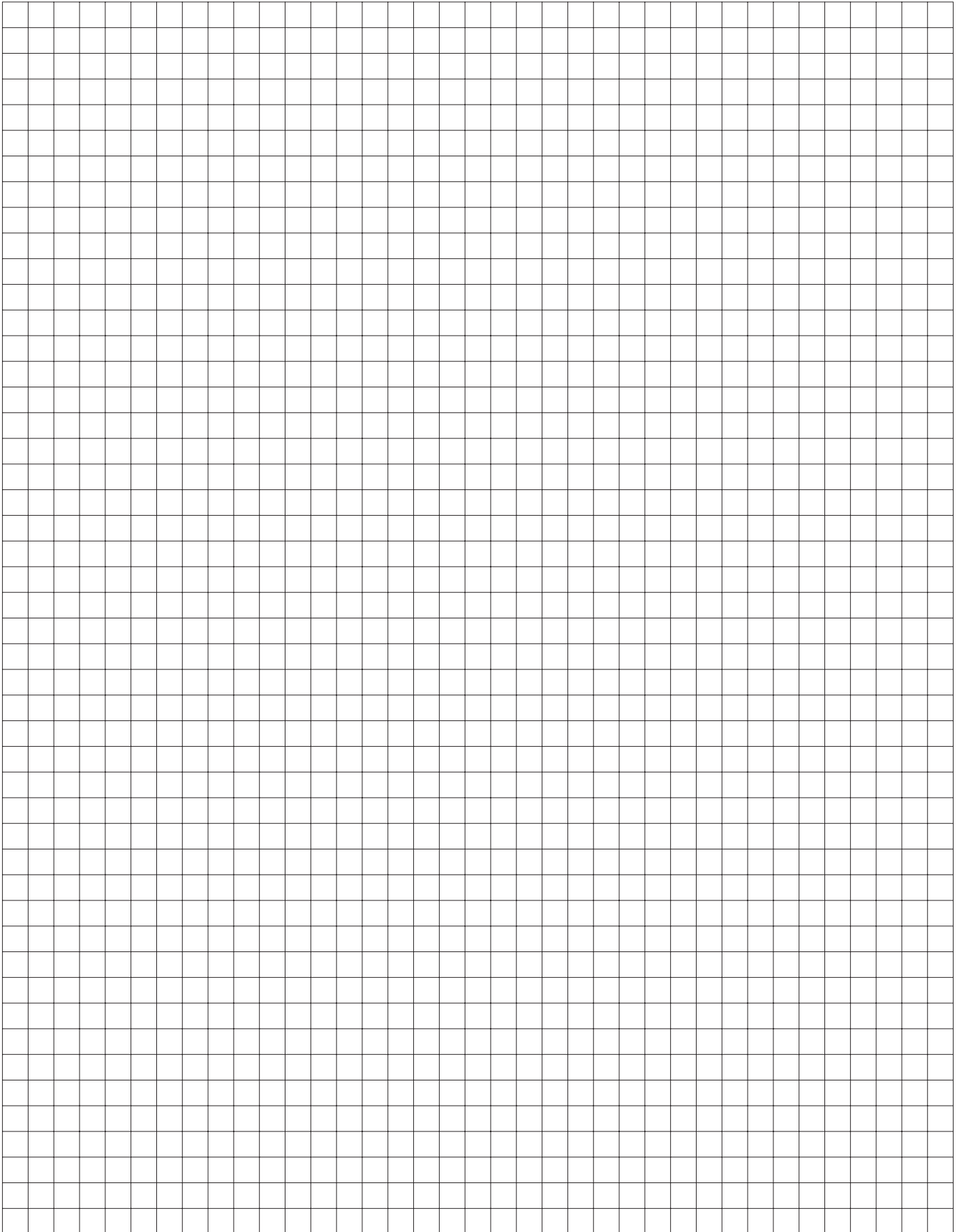

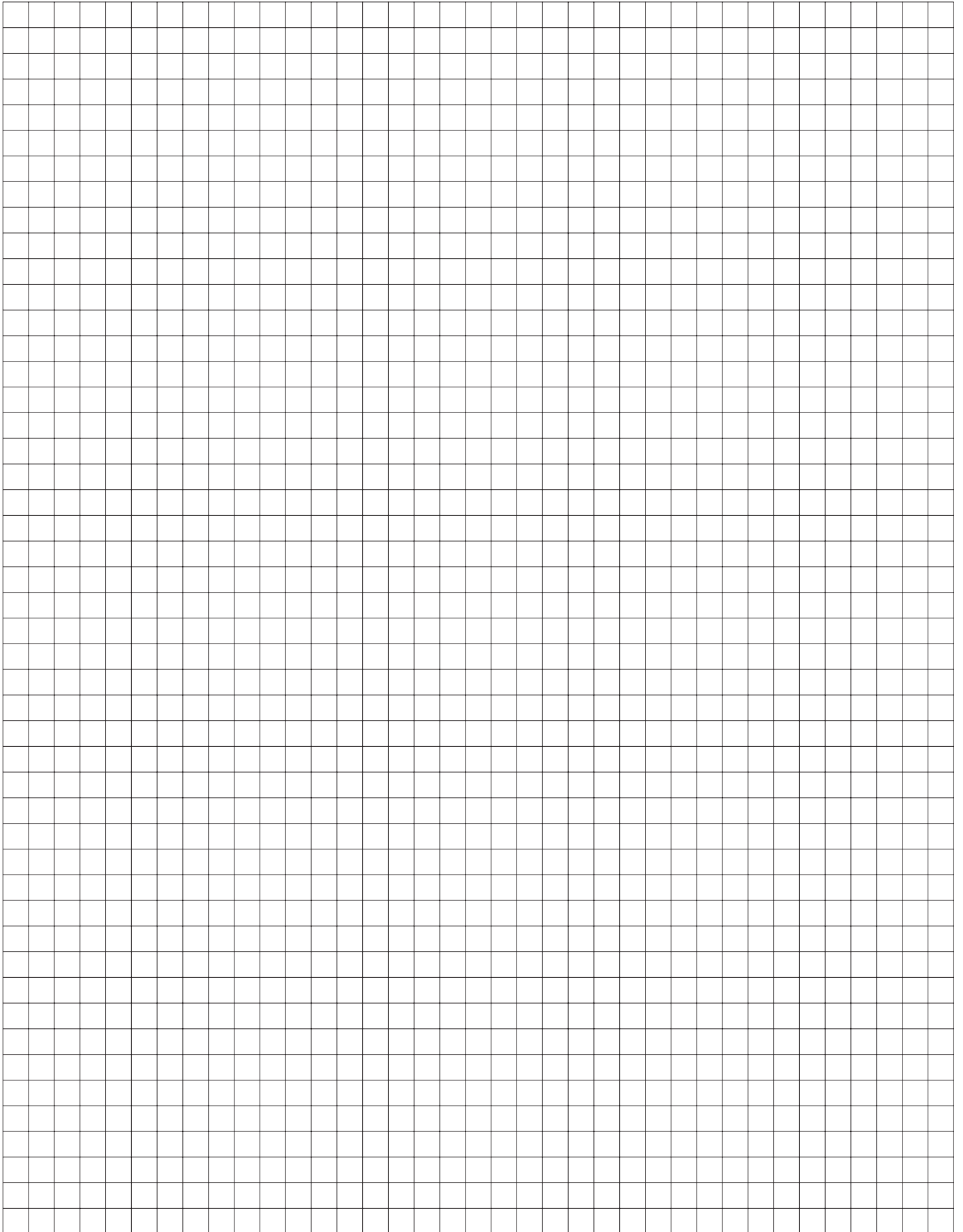

Bosch Rexroth AG

P.O. Box 13 57
97803 Lohr, Germany
Bgm.-Dr.-Nebel-Str. 2
97816 Lohr, Germany
Phone +49 9352 18-0
Fax +49 9352 18-8400

www.boschrexroth.com

Find your local contact person here:

www.boschrexroth.com/addresses-dcl