

Axial Piston Variable Pump A4VG (US-Version)

RA-A 92004/06.12 1/66
Replaces: 12.11

Data sheet

Series 40
Size 45 to 280
Nominal pressure 6500 psi (450 bar)
Maximum pressure 7250 psi (500 bar)
Closed circuit

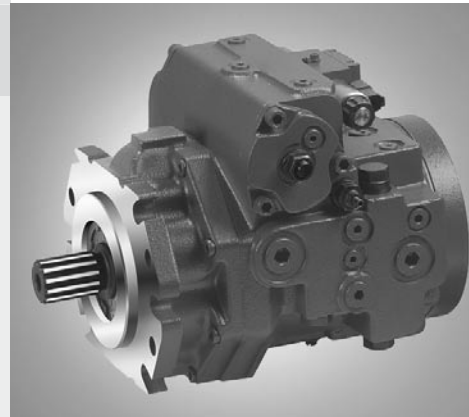

Contents

Ordering code for standard program	2
Technical data	6
HP – Proportional control hydr., pilot-pressure related	12
HW – Proportional control hydraulic, mechanical servo	13
EP – Proportional control electric	14
EZ – Two-point control electric	15
DA – Automatic control speed-related	16
HT – Hydraulic control, direct controlled	18
EV – Electric control, direct controlled	19
Dimensions size 45 to 280	20
Through drive dimensions	48
Overview of mounting options	51
Combination pumps A4VG + A4VG	52
Pressure cut-off	53
Bypass function	53
High-pressure relief valves	54
Mechanical stroke limiter	55
Ports X ₃ and X ₄ for stroking chamber pressure	55
Filtration boost circuit / external supply	56
Connector for solenoids	60
Speed sensor	60
Swivel angle sensor	61
Installation dimensions for coupling assembly	62
Installation instructions	63
General instructions	65

Features

- Variable axial piston pump of swashplate design for hydrostatic drives in closed circuit
- The flow is proportional to the drive speed and displacement.
- The flow can be infinitely varied by adjusting the swashplate angle.
- Flow direction changes smoothly when the swashplate is moved through the neutral position.
- A wide range of highly adaptable control devices with different control and regulating functions, for all important applications.
- Two pressure-relief valves are provided on the high-pressure side to protect the hydrostatic transmission (pump and motor) from overload.
- The high-pressure relief valves also function as boost valves.
- The integrated boost pump acts as a feed pump and control pressure supply.
- The maximum boost pressure is limited by a built-in low-pressure relief valve.
- High pressure level for high power density and good efficiency

Ordering code for standard program

A4V	G									/	40	A								A	0		-	
01	02	03	04	05	06	07	08	09			10	11	12	13	14	15	16	17	18	19	20	21	22	23

Axial piston unit

01	Swashplate design, variable, nominal pressure 6500 psi (450 bar), maximum pressure 7250 psi (500 bar)	A4V
----	---	------------

Operating mode

02	Pump, closed circuit	G
----	----------------------	----------

Sizes (NG)

03	Geometric displacement, see table of values on page 9	in cm ³	045	065	085	110	145	175	210	280
		in in ³ /rev	2.75	3.97	5.19	6.71	8.85	10.68	12.81	17.09

Control devices

			045	065	085	110	145	175	210	280		
04	Proportional control hydraulic	pilot-pressure related	○	●	○	○	○	○	○	○	HP1	
		mechanical servo, hexagon shaft with lever, free position ¹⁾	p = 90 to 260 psi (6 to 18 bar)	●	●	●	●	●	●	●	●	HW2
			with neutral position switch	●	●	●	●	●	●	●	●	HW8
04	Proportional control electric	U = 12 V DC	●	●	●	●	●	●	●	●	EP1	
		U = 24 V DC	●	●	●	●	●	●	●	●	EP2	
04	Two-point control electric	U = 12 V DC	●	●	●	●	●	●	●	●	EZ1	
		U = 24 V DC	●	●	●	●	●	●	●	●	EZ2	
04	Automatic control speed-related	U = 12 V DC	●	●	●	●	●	●	●	●	DA1	
		U = 24 V DC	●	●	●	●	●	●	●	●	DA2	
04	Hydraulic control, direct controlled		●	●	●	●	●	●	○	○	HT1	
04	Electric control, direct controlled, with one pressure reducing valve (DRE) and 4/3-directional valve	U = 12 V DC	●	●	●	●	●	●	-	-	EV1	
		U = 24 V DC	●	●	●	●	●	●	-	-	EV2	

Pressure cut-off (see page 53)

			045	065	085	110	145	175	210	280	
05	Without pressure cut-off	without bypass	●	●	●	●	●	●	●	●	0
		with bypass	○	○	●	●	●	●	○	○	C
	Pressure cut-off	with bypass	●	●	●	●	●	●	●	●	D

Connector for solenoids²⁾ (see page 60)

			045	065	085	110	145	175	210	280	
06	Without connector (without solenoid, only with hydraulic controls)		●	●	●	●	●	●	●	●	0
	DEUTSCH - molded connector, 2-pin – without suppressor diode		●	●	●	●	●	●	●	●	P

Swivel angle sensor (see page 61)

			045	065	085	110	145	175	210	280	
07	Without swivel angle sensor		●	●	●	●	●	●	●	●	0
	Electric swivel angle sensor mounted ³⁾		●	●	●	●	●	●	●	●	R

Additional functions (see page 55)

			045	065	085	110	145	175	210	280	
08	Without additional functions		●	●	●	●	●	●	●	●	0
	Mechanical stroke limiter, externally adjustable		●	●	●	●	●	●	●	●	M
	Ports X ₃ , X ₄ for stroking chamber pressure		●	●	●	●	●	●	●	●	T
	Mechanical stroke limiter and ports X ₃ , X ₄		●	●	●	●	●	●	●	●	B

● = Available ○ = On request - = Not available

■ = Preferred program

1) On delivery, the position of the lever may differ from that shown in the brochure or drawing. If necessary, the position of the lever can be adjusted by the customer.

2) Connectors for other electric components can deviate.

3) Please contact us if the swivel angle sensor is used for control

Ordering code for standard program

A4V	G									/	40	A		N						A	0		-	
01	02	03	04	05	06	07	08	09			10	11	12	13	14	15	16	17	18	19	20	21	22	23

DA control valve (see page 17)										EZ	EV	HP	HW	HT	DA	EP		
Without DA control valve										●	●	●	●	●	-	●	0	
DA control valve, fixed setting										-	-	●	●	●	●	●	1	
09	DA control valve, mech. adjustable with position lever									Actuating direction	right	-	-	●	●	●	●	2
											left	-	-	●	●	●	●	3
DA control valve, fixed setting and braking inch valve mounted, control with brake fluid										according to ISO 4925, no mineral oil based on mineral oil	-	-	-	-	-	○	-	4
											-	-	-	-	-	○	-	5
DA control valve, fixed setting, ports for pilot control device										-	-	●	●	●	●	●	6	

Series		
10	Series 4, index 0	40

Configuration of ports and fastening threads		
11	ANSI, port threads with O-ring seal according to ISO 11926	A

Directions of rotation			
12	Viewed on drive shaft	clockwise	R
		counter-clockwise	L

Seals		
13	NBR (nitrile-caoutchouc), shaft seal in FKM (fluor-caoutchouc)	N

Mounting flanges			045	065	085	110	145	175	210	280	
14	SAE J744	101-2	●	-	-	-	-	-	-	-	B2
		127-2	●	-	-	-	-	-	-	-	C2
		127-2/4	-	●	●	●	-	-	-	-	C6
		152-2/4	-	-	-	●	●	●	-	-	D6
		165-4	-	-	-	-	-	●	●	●	E4

Drive shafts (permissible input torques see page 11)			045	065	085	110	145	175	210	280	
15	Splined shaft ANSI B92.1a	1 1/4 in 14T 12/24DP	●	●	-	-	-	-	-	-	S7
		1 1/2 in 17T 12/24DP	●	○	-	-	-	-	-	-	S9
		1 3/8 in 21T 16/32DP	-	-	●	●	-	-	-	-	V8
		1 3/4 in 13T 8/16DP	-	-	●	●	●	●	-	-	T1
		2 in 15T 8/16DP	-	-	-	●	●	-	●	●	T2
		2 1/4 in 17T 8/16DP	-	-	-	-	●	●	○	●	T3

Service line ports		045	065	085	110	145	175	210	280	
16	SAE flange ports A and B, on left side (45°)	●	●	●	●	●	●	●	●	1
	SAE flange ports A and B, on right side (45°) ⁴⁾	●	●	-	-	●	●	●	●	2

● = Available ○ = On request - = Not available

■ = Preferred program

4) Only possible without mountable filter.

Ordering code for standard program

A4V	G									/	40	A		N						A	0		-	
01	02	03	04	05	06	07	08	09			10	11	12	13	14	15	16	17	18	19	20	21	22	23

Rotary group configurations and boost pump

		045	065	085	110	145	175	210	280		
17	Standard rotary group	boost pump integrated, through drive convertible									F
		without boost pump, through drive convertible									U
	High-speed rotary group	boost pump integrated, through drive convertible									V
		without boost pump, through drive convertible									W

Through drives (mounting options see page 51)

Flange SAE J744	Mounting variant		Coupling for splined shaft ⁵⁾			045	065	085	110	145	175	210	280		
	Diameter	Symbol ⁶⁾	Designation	Diameter	Designation										
Without through drive															
82-2 (A)	∅	A1	5/8 in	9T 16/32DP	S2	○	○	●	○	○	○	-	-	A1S2	
			3/4 in	11T 16/32DP	S3	○	○	○	●	-	-	●	-	A1S3	
	∞	A2	5/8 in	9T 16/32DP	S2	●	●	●	●	●	●	-	-	A2S2	
			3/4 in	11T 16/32DP	S3	●	○	-	-	-	-	-	-	A2S3	
101-2 (B)	∅	B1	7/8 in	13T 16/32DP	S4	○	●	●	●	●	●	-	-	B1S4	
			1 in	15T 16/32DP	S5	○	○	●	○	●	●	-	-	B1S5	
	∞	B2	7/8 in	13T 16/32DP	S4	●	●	●	●	●	●	-	-	B2S4	
			1 in	15T 16/32DP	S5	●	●	●	●	●	●	-	-	B2S5	
	♂	B5	7/8 in	13T 16/32DP	S4	○	○	○	○	○	○	-	-	B5S4	
			1 in	15T 16/32DP	S5	○	○	●	●	○	○	-	-	B5S5	
101-4 (B)	⊗	B4	7/8 in	13T 16/32DP	S4	○	○	○	○	●	○	-	-	B4S4	
			1 in	15T 16/32DP	S5	○	○	○	○	●	○	-	-	B4S5	
	∅	C1	1 in	15T 16/32DP	S5	-	-	-	-	○	-	-	-	C1S5	
			1 1/4 in	14T 12/24DP	S7	○	○	●	●	●	○	○	○	C1S7	
		∞	C2	1 in	15T 16/32DP	S5	-	-	-	-	●	○	-	-	C2S5
				1 1/4 in	14T 12/24DP	S7	●	●	●	●	●	●	●	●	C2S7
	♂	C5	1 3/8 in	21T 16/32DP	V8	-	-	●	-	●	●	-	-	C2V8	
			1 3/4 in	13T 8/16DP	T1	-	-	-	-	●	●	-	-	C2T1	
	127-2 (C)	∅	C4	1 in	15T 16/32DP	S5	-	-	-	-	○	-	-	-	C5S5
				1 1/4 in	14T 12/24DP	S7	○	○	○	●	○	○	○	○	C5S7
127-4 (C)	⊗	C4	1 1/4 in	14T 12/24DP	S7	-	-	●	●	●	●	-	-	C4S7	
			1 3/8 in	21T 16/32DP	V8	-	-	●	○	-	-	-	-	C4V8	
152-2 (D)	∞	D2	1 3/4 in	13T 8/16DP	T1	-	-	-	-	●	○	-	-	D2T1	
152-4 (D)	⊗	D4	1 3/8 in	21T 16/32DP	V8	-	-	○	●	-	-	-	-	D4V8	
			1 3/4 in	13T 8/16DP	T1	-	-	-	-	●	●	●	●	D4T1	
165-4 (E)	⊗	E4	1 3/4 in	13T 8/16DP	T1	-	-	-	-	○	●	-	-	E4T1	

● = Available ○ = On request - = Not available = Preferred program

5) Coupling for splined shaft according to ANSI B92.1a
 6) Mounting drillings pattern viewed on through drive with control at top

Ordering code for standard program

A4V	G									/	40	A		N						A	0	-	
01	02	03	04	05	06	07	08	09		10	11	12	13	14	15	16	17	18	19	20	21	22	23

Pressure-relief valves (see page 54)

045 065 085 110 145 175 210 280

19	High-pressure relief valve, direct controlled, fixed setting with low-pressure relief valve, fixed setting	●	●	●	●	●	●	●	●	●	●	●	●	●	●	●	●	●	●	●	●	●	●	A
----	---	---	---	---	---	---	---	---	---	---	---	---	---	---	---	---	---	---	---	---	---	---	---	---

Filtration boost circuit / external supply (see pages 56 to 59)

045 065 085 110 145 175 210 280

20	Filtration in the boost pump suction line	●	●	●	●	●	●	●	●	●	●	●	●	●	●	●	●	●	●	●	●	●	●	S	
	Filtration in the boost pump pressure line:																								
	Ports for external boost circuit filtration (F _e and F _a)	●	●	●	●	●	●	●	●	●	●	●	●	●	●	●	●	●	●	●	●	●	●	●	D
	Filter mounted with cold start valve ⁷⁾	●	●	●	●	●	●	●	●	●	●	●	●	●	●	●	●	●	●	●	●	○	○	○	F
	Filter mounted with cold start valve and electric contamination indicator ⁷⁾	●	●	●	●	●	●	●	●	●	●	●	●	●	●	●	●	●	●	●	●	○	○	○	B
External supply (on version without integrated boost pump)	●	●	●	●	●	●	●	●	●	●	●	●	●	●	●	●	●	●	●	●	○	○	○	E	

Pressure sensor

045 065 085 110 145 175 210 280

21	Without pressure sensor	●	●	●	●	●	●	●	●	●	●	●	●	●	●	●	●	●	●	●	●	●	●	0
----	-------------------------	---	---	---	---	---	---	---	---	---	---	---	---	---	---	---	---	---	---	---	---	---	---	---

Speed sensor (see page 60)

045 065 085 110 145 175 210 280

22	Without speed sensor	●	●	●	●	●	●	●	●	●	●	●	●	●	●	●	●	●	●	●	●	●	●	0
	DSA speed sensor mounted ⁸⁾	○	●	●	●	●	●	●	●	●	●	●	●	●	●	●	●	●	●	●	●	●	●	V

Standard / special version

23	Standard version																							0
	Standard version with installation variants, e. g. T ports against standard open or closed																							Y
	Special version																							S

● = Available ○ = On request - = Not available

■ = Preferred program

⁷⁾ Only for SAE flange ports A and B, on left side (45°)

⁸⁾ Specify ordering code of sensor acc. to data sheet (DSA - RE 95133) separately and observe the requirements on the electronics

Technical data

Hydraulic fluid

Before starting project planning, please refer to our data sheets RE 90220 (mineral oil), RE 90221 (environmentally acceptable hydraulic fluids) and RE 90222 (HFD hydraulic fluids) for detailed information regarding the choice of hydraulic fluid and application conditions.

The variable pump A4VG is not suitable for operation with HFA, HFB and HFC hydraulic fluids. If HFD or environmentally acceptable hydraulic fluids are used, the limitations regarding technical data or other seals must be observed. Please contact us.

Selection diagram

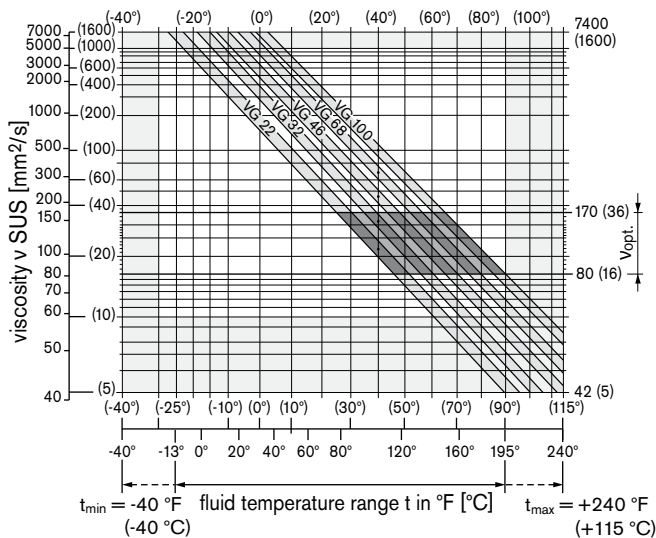

Details regarding the choice of hydraulic fluid

The correct choice of hydraulic fluid requires knowledge of the operating temperature in relation to the ambient temperature: in a closed circuit, the circuit temperature.

The hydraulic fluid should be chosen so that the operating viscosity in the operating temperature range is within the optimum range (v_{opt} see shaded area of the selection diagram). We recommend that the higher viscosity class be selected in each case.

Example: At an ambient temperature of X °F (X °C), an operating temperature of 140 °F (60 °C) is set in the circuit. In the optimum operating viscosity range (v_{opt} , shaded area), this corresponds to the viscosity classes VG 46 or VG 68; to be selected: VG 68.

Note

The case drain temperature, which is affected by pressure and speed, can be higher than the circuit temperature. At no point of the component may the temperature be higher than 240 °F (115 °C). The temperature difference specified below is to be taken into account when determining the viscosity in the bearing.

If the above conditions cannot be maintained due to extreme operating parameters, please contact us.

Viscosity and temperature of hydraulic fluid

	Viscosity [SUS (mm ² /s)]	Temperature	Comment
Transport and storage at ambient temperature		$T_{min} \geq -58$ °F (-50 °C) $T_{opt} = +41$ °F to +68 °F (+5 °C to +20 °C)	factory preservation: up to 12 months with standard, up to 24 months with long-term
(Cold) start-up ¹⁾	$v_{max} = 7400$ (1600)	$T_{St} \geq -40$ °F (-40 °C)	$t \leq 3$ min, without load ($p \leq 725$ psi (50 bar)), $n \leq 1000$ rpm
Permissible temperature difference		$\Delta T \leq 45$ °F (25 °C)	between axial piston unit and hydraulic fluid
Warm-up phase	$v < 7400$ to 1850 (1600 to 400)	$T = -40$ °F to -13 °F (-40 °C to -25 °C)	at $p \leq 0.7 \cdot p_{nom}$, $n \leq 0.5 \cdot n_{nom}$ and $t \leq 15$ min
Operating phase			
Temperature difference		$\Delta T = \text{approx. } 10$ °F (5 °C)	between hydraulic fluid in the bearing and at port T.
Maximum temperature		+240 °F (+115 °C) +230 °F (+110 °C)	in the bearing measured at port T
Continuous operation	$v = 1850$ to 47 (400 to 10) $v_{opt} = 170$ to 74 (36 to 16)	$T = -13$ °F to +195 °F (-25 °C to +90 °C)	measured at port T, no restriction within the permissible data
Short-term operation	$v_{min} \geq 32$ (7)	$T_{max} = +230$ °F (+110 °C)	measured at port T, $t < 3$ min, $p < 0.3 \cdot p_{nom}$
FKM shaft seal ¹⁾		$T \leq +240$ °F (+115 °C)	see page 7

1) At temperatures below -13 °F (-25 °C), an NBR shaft seal is required (permissible temperature range: -40 °F to +195 °F (-40 °C to +90 °C)).

Technical data

Filtration of the hydraulic fluid

Finer filtration improves the cleanliness level of the hydraulic fluid, which increases the service life of the axial piston unit.

To ensure the functional reliability of the axial piston unit, a gravimetric analysis of the hydraulic fluid is necessary to determine the amount of solid contaminant and to determine the cleanliness level according to ISO 4406. A cleanliness level of at least 20/18/15 is to be maintained.

Depending on the system and the application, for the A4VG, we recommend

Filter cartridges $\beta_{20} \geq 100$.

With an increasing differential pressure at the filter cartridges, the β value must not deteriorate.

At very high hydraulic fluid temperatures 195 °F to maximum 240 °F (90 °C to maximum 115 °C), a cleanliness level of at least 19/17/14 according to ISO 4406 is necessary.

If the above classes cannot be achieved, please contact us. For notes on filtration types, see page 56.

Shaft seal

Permissible pressure loading

The service life of the shaft seal is influenced by the speed of the axial piston unit and the case drain pressure (case pressure p_G). The mean differential pressure of 30 psi (2 bar) between the case and the ambient pressure may not be enduringly exceeded at normal operating temperature. For a higher differential pressure at reduced speed, see diagram. Momentary pressure spikes ($t < 0.1$ s) of up to 145 psi (10 bar) are permitted. The service life of the shaft seal decreases with an increase in the frequency of pressure spikes.

The case pressure must be equal to or higher than the ambient pressure.

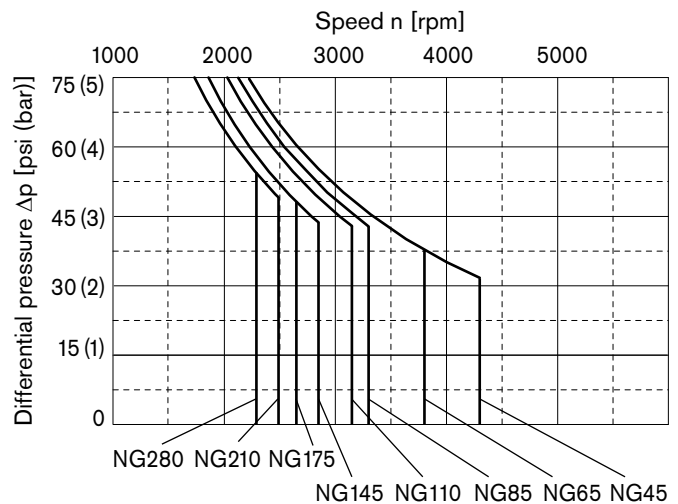

These values are valid for an ambient pressure $p_{abs} = 15$ psi (1 bar).

Temperature range

The FKM shaft seal may be used for case drain temperatures from -13 °F to +240 °F (-25 °C to +115 °C).

Note

For application cases below -13 °F (-25 °C), an NBR shaft seal is required (permissible temperature range: -40 °F to +195 °F (-40 °C to +90 °C)).

State NBR shaft seal in plain text when ordering.

Please contact us.

Technical data

Operating pressure range

(operating with mineral oil)

Pressure at service line port A or B

Nominal pressure p_{nom} _____ 6500 psi (450 bar) absolute

Maximum pressure p_{max} _____ 7250 psi (500 bar) absolute
 Single operating period _____ 10 s
 Total operating period _____ 300 h

Minimum pressure (high-pressure side) _____ 365 psi (25 bar) absolute

Minimum pressure (low-pressure side) _____ 145 psi (10 bar) above p_G
 (boost pressure setting must be higher, depending on system)

Rate of pressure change $R_{A\ max}$ _ 130000 psi/s (9000 bar/s)

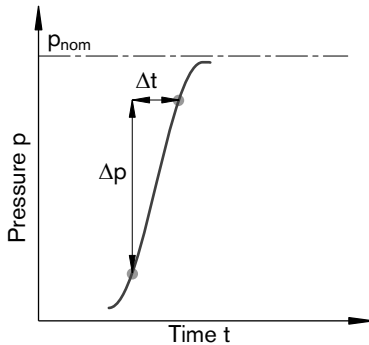

Boost pump

Pressure at suction port S

Continuous $p_{S\ min}$ ($v \leq 140\ SUS$) _____ ≥ 12 psi absolute
 ($v \leq 30\ mm^2/s$) _____ ≥ 0.8 bar absolute)

Short-term, on cold start
 ($t < 3$ min) _____ ≥ 7.5 psi (0.5 bar) absolute

Maximum $p_{S\ max}$ _____ ≤ 75 psi (5 bar) absolute

Nominal pressure $p_{Sp\ nom}$ _____ 365 psi (25 bar) absolute

Maximum pressure $p_{Sp\ max}$ _____ 580 psi (40 bar) absolute

Control pressure

To ensure the function of the control, the following control pressure is required depending on the speed and operating pressure (measuring point, port P_S):

For controls EP, HW and HP

Minimum control pressure
 $p_{St\ min}$ (at $n = 2000$ rpm) _____ 290 psi (20 bar) above p_G

For controls DA, HT, EV, EZ

Minimum control pressure
 $p_{St\ min}$ (at $n = 2000$ rpm) _____ 365 psi (25 bar) above p_G

Note

Values for other hydraulic fluids, please contact us.

p_G = case pressure

Definition

Nominal pressure p_{nom}

The nominal pressure corresponds to the maximum design pressure.

Maximum pressure p_{max}

The maximum pressure corresponds to the maximum operating pressure within the single operating period. The sum of the single operating periods must not exceed the total operating period.

Minimum pressure (high-pressure side)

Minimum pressure at the high-pressure side (A or B) which is required in order to prevent damage to the axial piston unit.

Minimum pressure (low-pressure side)

Minimum pressure at the low-pressure side (A or B), which is required in order to prevent damage to the axial piston unit.

Rate of pressure change R_A

Maximum permissible rate of pressure rise and reduction during a pressure change over the entire pressure range.

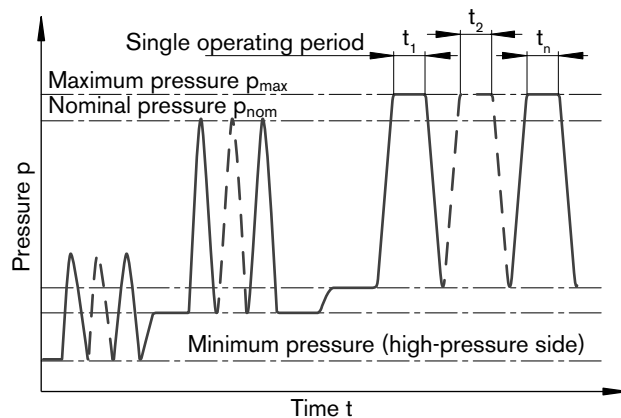

Total operating period = $t_1 + t_2 + \dots + t_n$

Technical data

Table of values (theoretical values, without efficiency levels and tolerances; values rounded)

Size	NG		45	65	85	110	145	175	210	280	
Displacement geometric, per revolution variable pump	$V_{g \max}$	in ³	2.76	3.98	5.21	6.74	8.87	10.70	12.85	17.10	
		cm ³	45.3	65.2	85.4	110.4	145.3	175.4	210.6	280.3	
	$V_{g Sp}$	in ³	0.67	0.88	1.16	1.50	1.95	2.38	2.81	3.66	
boost pump (at p = 290 psi (20 bar))		cm ³	11	14.5	19	24.5	32	39	46	60	
Standard rotary group											
Speed ¹⁾											
maximum at $V_{g \max}$	$n_{nom S}$	rpm	4300	3800	3300	3150	2850	2650	2500	2400	
at $\Delta p \geq 580$ psi (40 bar) (t < 15 s)	$n_{max 40}$	rpm	4500	4000	3500	3350	3000	2800	2650	2550	
minimum	n_{min}	rpm	500	500	500	500	500	500	500	500	
Flow											
at $n_{nom S}$ and $V_{g \max}$	q_v	gpm	51.5	65.5	74.5	91.9	109.4	122.7	139.2	177.8	
		L/min	195	248	282	348	414	465	527	673	
Power ²⁾											
$\Delta p = 6250$ psi	P	hp	188	239	271	334	398	447	506	646	
at $n_{nom S}$, $V_{g \max}$ and $\Delta p = 430$ bar		kW	140	178	202	249	297	333	377	482	
High-speed rotary group											
Speed ¹⁾											
maximum at $V_{g \max}$	$n_{nom H}$	rpm	-	-	-	3400	3050	3000	-	-	
at $\Delta p \geq 580$ psi (40 bar) (t < 15 s)	$n_{max 40}$	rpm	-	-	-	3600	3200	3100	-	-	
minimum	n_{min}	rpm	-	-	-	500	500	500	-	-	
Flow											
at $n_{nom H}$ and $V_{g \max}$	q_v	gpm	-	-	-	99.1	117.0	139.0	-	-	
		L/min	-	-	-	375	443	526	-	-	
Power ²⁾											
$\Delta p = 6250$ psi	P	hp	-	-	-	361	426	506	-	-	
at $n_{nom H}$, $V_{g \max}$ and $\Delta p = 430$ bar		kW	-	-	-	269	318	377	-	-	
Torque ²⁾											
at $V_{g \max}$ and	$\Delta p = 6250$ psi	T	lb-ft	229	329	431	558	733	885	1063	1415
	$\Delta p = 430$ bar		Nm	310	446	584	756	994	1200	1441	1918
	$\Delta p = 1450$ psi	T	lb-ft	53	77	100	130	170	206	247	329
	$\Delta p = 100$ bar		Nm	72	104	136	176	231	279	335	446
Rotary stiffness drive shaft											
1 1/4	S7	c	lb-ft/rad	60568	75294	-	-	-	-	-	-
			kNm/rad	82.1	102	-	-	-	-	-	-
1 1/2	S9	c	lb-ft/rad	69986	97805	-	-	-	-	-	-
			kNm/rad	94.8	133	-	-	-	-	-	-
1 3/8	V8	c	lb-ft/rad	-	-	100167	123593	-	-	-	-
			kNm/rad	-	-	136	168	-	-	-	-
1 3/4	T1	c	lb-ft/rad	-	-	122536	4)	182841	193690	-	-
			kNm/rad	-	-	166	4)	248	263	-	-
2	T2	c	lb-ft/rad	-	-	-	182317	218661	-	294462	342432
			kNm/rad	-	-	-	247	296	-	399	464
2 1/4	T3	c	lb-ft/rad	-	-	-	-	-	273789	349074	421398
			kNm/rad	-	-	-	-	-	371	473	571
Moment of inertia for rotary group											
J_{GR}			lb-ft ²	0.1139	0.2112	0.3322	0.5173	0.7831	1.3526	1.4998	2.3137
			kgm ²	0.0048	0.0089	0.014	0.0218	0.0330	0.0570	0.0632	0.0975
Maximum angular acceleration ³⁾											
α			rad/s ²	28000	22000	18000	14500	12000	10000	8000	5000
Case volume											
V			gal	0.37	0.40	0.61	0.66	0.87	0.82	1.29	1.43
			L	1.4	1.5	2.3	2.5	3.3	3.1	4.9	5.4
Mass approx. (without through drive)											
m			lbs	121	128	170	194	234	254	335	353
			kg	55	58	77	88	106	115	152	160

1) The values are valid: - for the optimum viscosity range from $v_{opt} = 167.04$ to 74.24 SUS (36 to 16 mm²/s)
- with hydraulic fluid based on mineral oils

2) Without boost pump

3) The data are valid for values between the minimum required and maximum permissible speed.

Valid for external excitation (e. g. engine 2 to 8 times rotary frequency; cardan shaft twice the rotary frequency).

The limit value applies for a single pump only. The load capacity of the connection parts must be considered.

4) On request

Note

Operation above the maximum values or below the minimum values may result in a loss of function, a reduced service life or in the destruction of the axial piston unit. We recommend testing the loads by means of experiment or calculation / simulation and comparison with the permissible values.

Technical data

Permissible radial and axial forces of the drive shafts

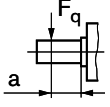
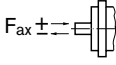
Size	NG		45	45	65	65	85	85	
Drive shaft		in	1 1/4	1 1/2	1 1/4	1 1/2	1 3/8	1 3/4	
Maximum radial force at distance a (from shaft collar)		$F_{q \max}$	lb	781	668	1231	1050	1515	1204
			N	3474	2970	5474	4670	6740	5356
		a	in	0.94	1.06	0.94	1.06	0.94	1.32
			mm	24	27	24	27	24	33.5
Maximum axial force		+ $F_{ax \max}$	lb	785	785	967	967	1323	1323
			N	3490	3490	4300	4300	5885	5885
		- $F_{ax \max}$	lb	519	519	607	607	835	835
			N	2310	2310	2700	2700	3715	3715

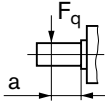
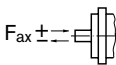
Size	NG		110	110	110	145	145	175	175	
Drive shaft		in	1 3/8	1 3/4	2	1 3/4	2	1 3/4	2 1/4	
Maximum radial force at distance a (from shaft collar)		$F_{q \max}$	lb	2141	1682	1472	2077	1818	2282	1819
			N	9524	7483	6548	9241	8086	10151	8090
		a	in	0.94	1.32	1.57	1.32	1.57	1.32	1.57
			mm	24	33.5	40	33.5	40	33.5	40
Maximum axial force		+ $F_{ax \max}$	lb	1417	1417	1417	1520	1520	1630	1630
			N	6305	6305	6305	6763	6763	7252	7252
		- $F_{ax \max}$	lb	921	921	921	997	997	1067	1067
			N	4095	4095	4095	4437	4437	4748	4748

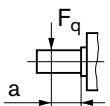
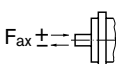
Size	NG		210	210	280	280	
Drive shaft		in	2	2 1/4	2	2 1/4	
Maximum radial force at distance a (from shaft collar)		$F_{q \max}$	lb	2514	2261	3274	2980
			N	11185	10059	14562	13256
		a	in	1.57	1.57	1.57	1.57
			mm	40	40	40	40
Maximum axial force		+ $F_{ax \max}$	lb	1745	1745	1900	1900
			N	7760	7760	8450	8450
		- $F_{ax \max}$	lb	1133	1133	1158	1158
			N	5040	5040	5150	5150

Note

Special requirements apply in the case of belt drive and cardan shaft. Please contact us.

Technical data

Determining the operating characteristics

Flow $q_v = \frac{V_g \cdot n \cdot \eta_v}{231}$ [gpm] $\left(\frac{V_g \cdot n \cdot \eta_v}{1000} \right)$ [L/min] $V_g =$ Displacement per revolution in in³ (cm³)

Torque $T = \frac{V_g \cdot \Delta p}{24 \cdot \pi \cdot \eta_{mh}}$ [[lb-ft]] $\left(\frac{V_g \cdot \Delta p}{20 \cdot \pi \cdot \eta_{mh}} \right)$ [Nm] $\Delta p =$ Differential pressure in psi (bar)

Power $P = \frac{2 \pi \cdot T \cdot n}{33000} = \frac{q_v \cdot \Delta p}{1714 \cdot \eta_t}$ [hp] $\left(\frac{2 \pi \cdot T \cdot n}{60000} = \frac{q_v \cdot \Delta p}{600 \cdot \eta_t} \right)$ [kW] $n =$ Speed in rpm

$\eta_v =$ Volumetric efficiency
 $\eta_{mh} =$ Mechanical-hydraulic efficiency
 $\eta_t =$ Total efficiency ($\eta_t = \eta_v \cdot \eta_{mh}$)

Permissible input and through-drive torques

Size	NG		45	65	85	110	145	175	210	280
Torque at $V_{g \max}$ and $\Delta p = 6250 \text{ psi}^{1)}$	T	lb-ft	229	330	432	559	735	887	1063	1415
		Nm	310	446	584	756	994	1200	1441	1918
Input torque at drive shaft, maximum ²⁾										
S7	1 1/4 in	$T_{E \max}$	lb-ft	444	444	-	-	-	-	-
			Nm	602	602	-	-	-	-	-
S9	1 1/2 in	$T_{E \max}$	lb-ft	830	830	-	-	-	-	-
			Nm	1125	1125	-	-	-	-	-
V8	1 3/8 in	$T_{E \max}$	lb-ft	-	-	715	715	-	-	-
			Nm	-	-	970	970	-	-	-
T1	1 3/4 in	$T_{E \max}$	lb-ft	-	-	1210	1210	1210	1210	-
			Nm	-	-	1640	1640	1640	1640	-
T2	2 in	$T_{E \max}$	lb-ft	-	-	-	1969	1969	-	1969
			Nm	-	-	-	2670	2670	-	2670
T3	2 1/4 in	$T_{E \max}$	lb-ft	-	-	-	-	-	3002	3002
			Nm	-	-	-	-	-	4070	4070
Maximum through-drive torque		$T_{D \max}$	lb-ft	384	384	689	689	1066	1066	1948
			Nm	521	521	934	934	1445	1445	2641

- 1) Efficiency not considered
- 2) For drive shafts without radial force

Torque distribution

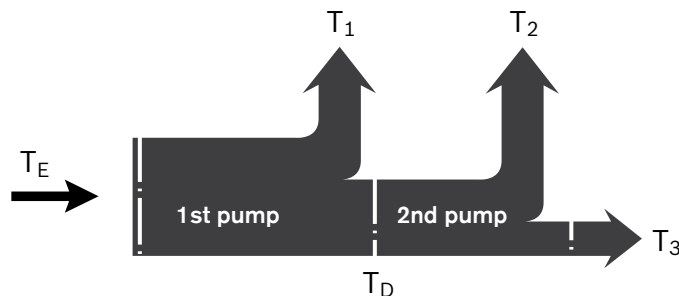

T_E and T_D consists as follows:

$$T_E = T_1 + T_2 + T_3$$

$$T_D = T_2 + T_3$$

$$T_E < T_{E \max}$$

$$T_D < T_{D \max}$$

HP – Proportional control hydraulic, pilot-pressure related

The output flow of the pump is infinitely variable between 0 to 100 %, proportional to the difference in pilot pressure applied to the two control ports (Y₁ and Y₂).

The pilot signal, coming from an external source, is a pressure signal. Flow is negligible, as the pilot signal acts only on the spool of the control valve.

This valve spool then directs control oil into and out of the stroking cylinder to adjust pump displacement as required.

A feedback lever, connected to the stroking piston maintains the pump flow for any given pilot signal within the control range.

If the pump is also equipped with a DA control valve (see page 17), automotive operation is possible for travel drives.

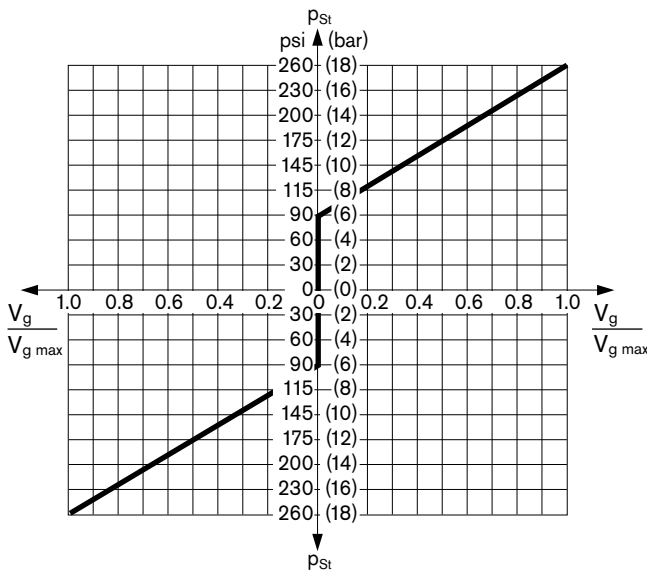

- V_g = Displacement at p_{St}
- V_{g max} = Displacement at p_{St} = 260 psi (18 bar)
- Pilot signal p_{St} = 90 to 260 psi (6 to 18 bar) (at port Y₁, Y₂)
- Beginning of control at 90 psi (6 bar)
- End of control at 260 psi (18 bar) (maximum displacement V_{g max})

Note

In the neutral position, the HP control module must be vented to reservoir via the external pilot control device.

Correlation

Direction of rotation - Control - Flow direction

	Pilot signal	Control pressure	Flow direction	Operating pressure
Direction of rotation cw	Y ₁	X ₁	B to A	M _A
	Y ₂	X ₂	A to B	M _B
Direction of rotation ccw	Y ₁	X ₁	A to B	M _B
	Y ₂	X ₂	B to A	M _A

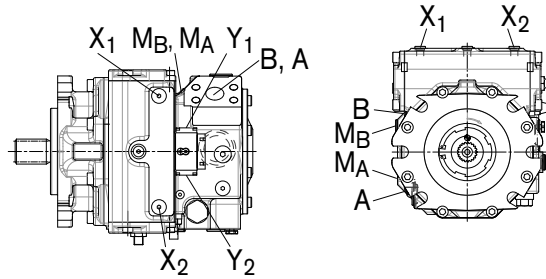

Note

The spring return feature in the control module is not a safety device

The control module can stick in an undefined position by internal contamination (contaminated hydraulic fluid, abrasion or residual contamination from system components). As a result, the control will no longer respond correctly to the operator's commands.

Check whether the application on your machine requires additional safety measures, in order to bring the driven actuator into a controlled and safe position (immediate stop). If necessary, make sure these are properly implemented.

Schematic

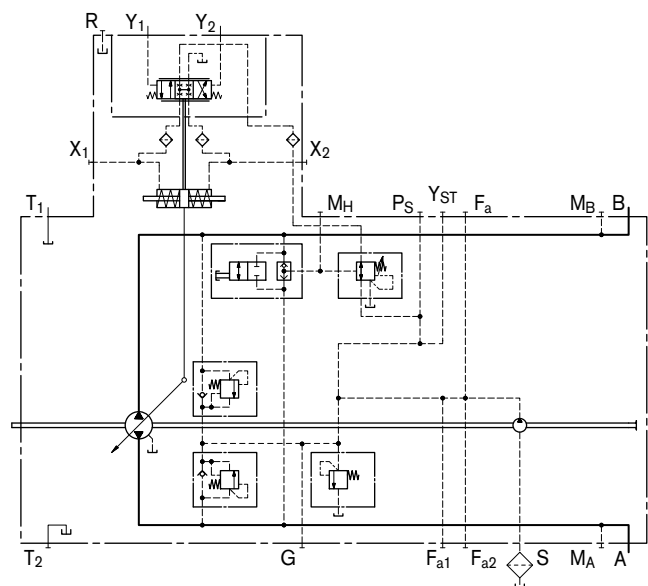

HW – Proportional control hydraulic, mechanical servo

The output flow of the pump is infinitely variable between 0 to 100 %, proportional to the swivel angle of the control lever between 0° and ±29° from the spring centered zero flow position.

A feedback lever, connected to the stroking piston maintains the pump flow for any given position of the control lever between 0° and 29°.

If the pump is also equipped with a DA control valve (see page 17), automotive operation is possible for travel drives.

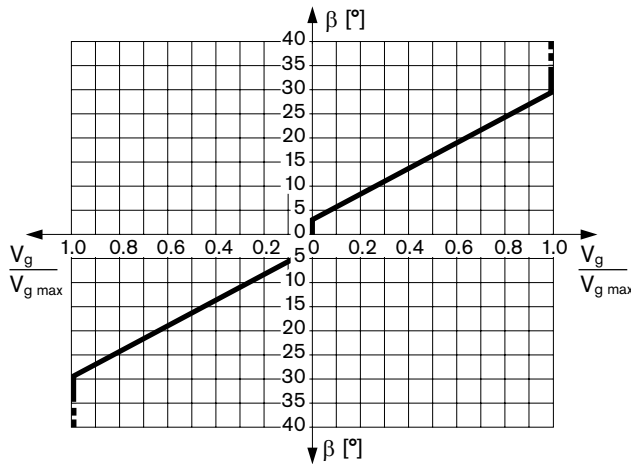

Swivel angle β at the control lever for pump displacement change:

Beginning of control at $\beta = 3^\circ$

End of control at $\beta = 29^\circ$ (maximum displacement $V_{g \text{ max}}$)

Mechanical stop for $\beta: \pm 40^\circ$

The maximum required torque at the lever is 15 lb-in (170 Ncm). To prevent damage to the HW control module, a positive mechanical stop must be provided for the HW control lever.

Note

Spring centering enables the pump, depending on pressure and speed, to move automatically to the neutral position ($V_g = 0$) as soon as there is no longer any torque on the control lever of the HW control module (regardless of deflection angle).

Variation: neutral position switch

The switch contact in the neutral position switch is closed when the control lever on the HW control module is in its neutral position. The switch opens when the control lever is moved out of neutral in either direction.

Thus, the neutral position switch provides a monitoring function for drive units that require the pump to be in the neutral position during certain operating conditions (e. g. starting diesel engines).

Technical data, neutral position switch	
Load capacity	20 A (continuous), without switching operating
Switching capacity	15 A / 32 V (resistive load)
	4 A / 32 V (inductive load)
Connector design	DEUTSCH DT04-2P-EP04 (mating connector, see page 60)

Correlation

Direction of rotation - Control - Flow direction

	Lever direction	Control pressure	Flow direction	Operating pressure
Direction of rotation cw	a	X ₁	B to A	M _A
	b	X ₂	A to B	M _B
Direction of rotation ccw	a	X ₁	A to B	M _B
	b	X ₂	B to A	M _A

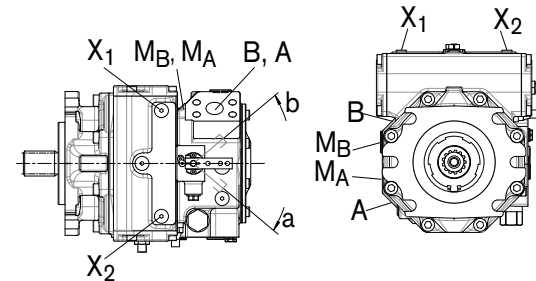

Schematic

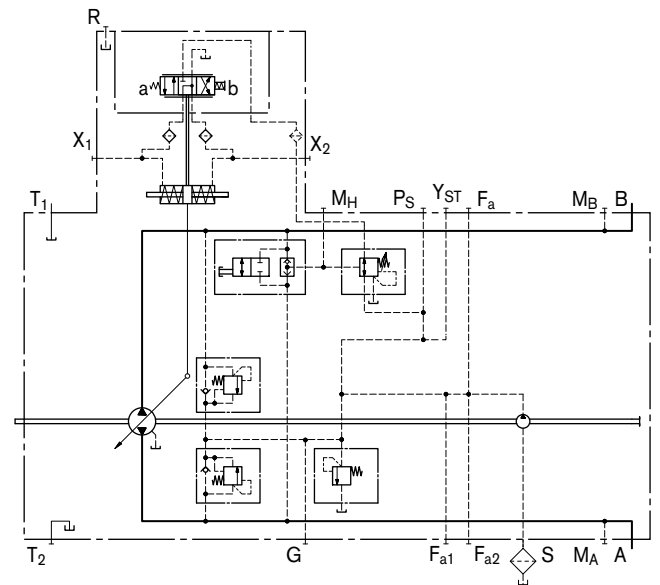

Schematic with neutral position switch

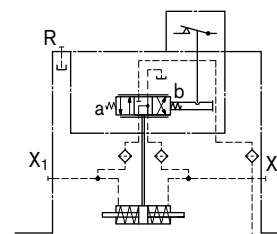

EP – Proportional control electric

The output flow of the pump is infinitely variable between 0 to 100 %, proportional to the electrical current supplied to solenoid a or b.

The electrical energy is converted into a force acting on the spool of the control valve.

This valve spool then directs control oil into and out of the stroking cylinder to adjust pump displacement as required.

A feedback lever, connected to the stroking piston maintains the pump flow for any given current within the control range.

If the pump is also equipped with a DA control valve (see page 17), automotive operation is possible for travel drives.

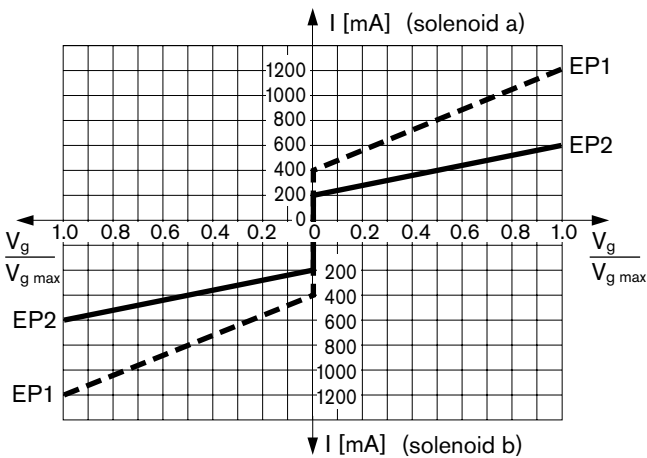

Standard

Proportional solenoid without manual override.

On request

Proportional solenoid with manual override and spring return.

Technical data, solenoid

	EP1	EP2
Voltage	12 V ($\pm 20\%$)	24 V ($\pm 20\%$)
Control current		
Beginning of control at $V_g = 0$	400 mA	200 mA
End of control at $V_g = V_{g,max}$	1200 mA	600 mA
Limiting current	1.54 A	0.77 A
Nominal resistance (at 68 °F (20 °C))	5.5 Ω	22.7 Ω
Dither frequency	100 Hz	100 Hz
Duty cycle	100 %	100 %
Type of protection	see connector design page 60	

The following electronic controllers and amplifiers are available for controlling the proportional solenoids:

- BODAS controller RC
 - Series 20 _____ RE 95200
 - Series 21 _____ RE 95201
 - Series 22 _____ RE 95202
 - Series 30 _____ RE 95203, RE 95204
- and application software
- Analog amplifier RA _____ RE 95230

Further information can also be found on the Internet at www.boschrexroth.com/mobile-electronics.

Note

The spring return feature in the control module is not a safety device

The control module can stick in an undefined position by internal contamination (contaminated hydraulic fluid, abrasion or residual contamination from system components). As a result, the control will no longer respond correctly to the operator's commands.

Check whether the application on your machine requires additional safety measures, in order to bring the driven actuator into a controlled and safe position (immediate stop). If necessary, make sure these are properly implemented.

Correlation

Direction of rotation - Control - Flow direction

	Actuation of solenoid	Control pressure	Flow direction	Operating pressure	
Direction of rotation	cw	a	X ₁	B to A	M _A
		b	X ₂	A to B	M _B
Direction of rotation	ccw	a	X ₁	A to B	M _B
		b	X ₂	B to A	M _A

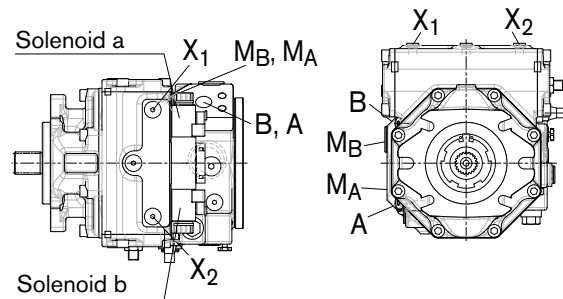

Schematic

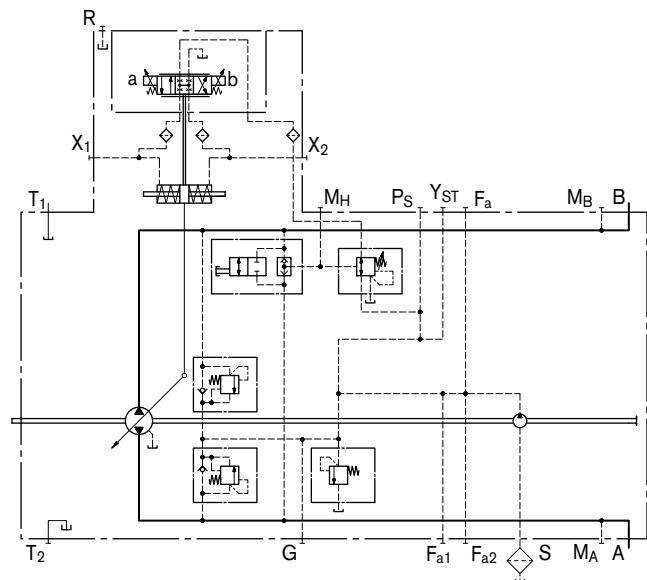

EZ – Two-point control electric

By energizing either switching solenoid a or b, internal control pressure is connected directly to the stroking piston and the pump swivels to maximum displacement. With the EZ control, pump flow is switchable between $V_g = 0$ and $V_{g \max}$. Flow direction is determined by which solenoid is energized.

Technical data, solenoid

	EZ1	EZ2
Voltage	12 V ($\pm 20\%$)	24 V ($\pm 20\%$)
Neutral position $V_g = 0$	de-energized	de-energized
Displacement $V_{g \max}$	energized	energized
Nominal resistance (at 68 °F (20 °C))	5.5 Ω	21.7 Ω
Nominal power	26.2 W	26.5 W
Minimum required current	1.32 A	0.67 A
Duty cycle	100 %	100 %
Type of protection see connector design page 60		

Standard

Switching solenoid without manual override.

On request

Switching solenoid with manual override and spring return.

Correlation

Direction of rotation - Control - Flow direction

	Actuation of solenoid	Control pressure	Flow direction	Operating pressure
Direction of rotation CW	a	X_2	A to B	M_B
	b	X_1	B to A	M_A
Direction of rotation CCW	a	X_2	B to A	M_A
	b	X_1	A to B	M_B

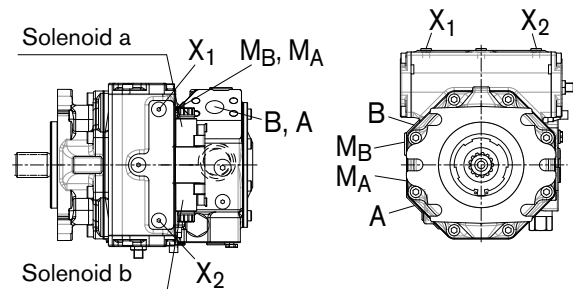

Schematic

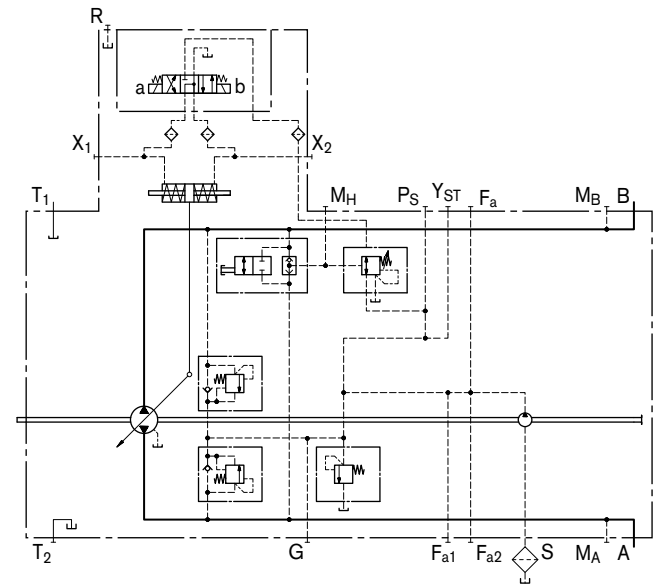

DA – Automatic control speed-related

The DA closed loop control is an engine speed-dependent system for travel drives. The built-in DA control valve generates a control pressure which is proportional to pump (engine) drive speed. This control pressure is directed to the stroking cylinder of the pump by a solenoid actuated 4/3-way directional valve. The pump displacement is infinitely variable in each flow direction and is influenced by both pump drive speed and system pressure. The flow direction (e. g. machine moving forward or backward) is determined by either solenoid a or b being activated.

Increasing pump drive speed generates a higher control pressure from the DA control valve, with a subsequent increase in pump flow.

Depending on the selected pump operating characteristics, increasing system pressure (e. g. machine load) causes the pump to swivel back towards a smaller displacement. Engine overload protection (anti-stall) is achieved by the combination of this pressure-related pump de-stroking, and the reduction of control pressure as the engine speed drops.

Any additional power requirement, e. g. for hydraulic functions from attachments, could cause the engine speed to drop further. This would cause a further reduction in control pressure and thus of pump displacement. Automatic power distribution and full exploitation of the available power are achieved in this way, both for the travel drive and for the implement hydraulics, with priority given to the implement hydraulics.

Various override options are available for the DA control function to allow controlled operation of the implement hydraulics with high rpm at reduced vehicle speed.

The DA control valve can also be used in pumps with EP, HW, HT and HP control module to protect the combustion engine against overload.

DA closed loop control is only suitable for certain types of drive systems and requires review of the engine and vehicle parameters to ensure that the pump is used correctly and that machine operation is safe and efficient. We recommend that all DA applications be reviewed by a Bosch Rexroth application engineer.

Technical data, solenoid

	DA1	DA2
Voltage	12 V (±20 %)	24 V (±20 %)
Neutral position $V_g = 0$	de-energized	de-energized
Displacement $V_{g \max}$	energized	energized
Nominal resistance (at 68 °F (20 °C))	5.5 Ω	21.7 Ω
Nominal power	26.2 W	26.5 W
Minimum required current	1.32 A	0.67 A
Duty cycle	100 %	100 %
Type of protection	see connector design page 60	

Standard

Switching solenoid without manual override.

On request

Switching solenoid with manual override and spring return.

Correlation

Direction of rotation - Control - Flow direction

Direction of rotation		Actuation of solenoid	Control pressure	Flow direction	Operating pressure
cw	a	X ₂	X ₂	A to B	M _B
	b	X ₁	X ₁	B to A	M _A
ccw	a	X ₂	X ₂	B to A	M _A
	b	X ₁	X ₁	A to B	M _B

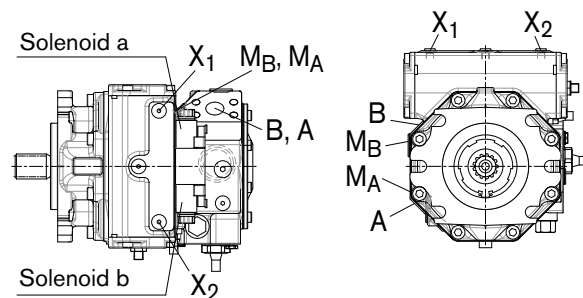

DA – Automatic control speed-related

Function and control of DA control valves

DA control valve fixed setting (1)

Control pressure is generated in relation to drive speed. When ordering, state in plain text: start of control (set at factory).

Schematic

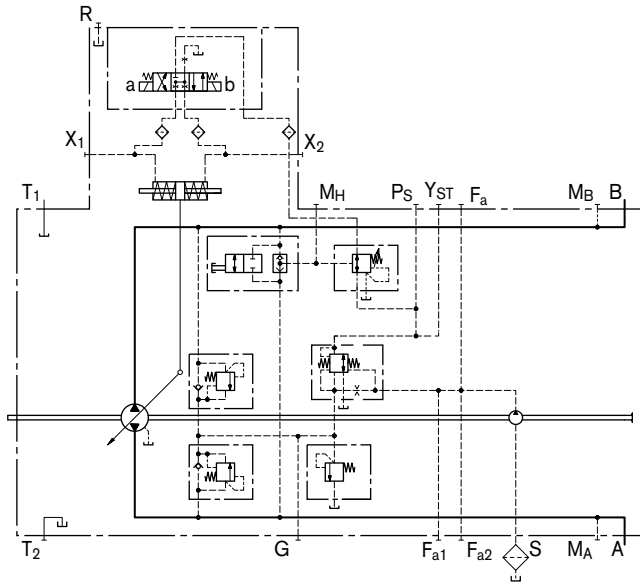

DA control valve mechanically adjustable with position lever (2, 3)

Control pressure is generated in relation to drive speed. When ordering, state in plain text: start of control (set at factory).

Any reduction of the control pressure possible, independently of the drive speed, through mechanical actuation of the position lever (inch function).

The maximum permissible actuation torque at the position lever is $T_{max} = 3 \text{ lb-ft (4 Nm)}$.

Maximum angle of rotation 70° , lever position: any.

Version 2

Actuating direction of the position lever: right

Version 3

Actuating direction of the position lever: left

Schematic

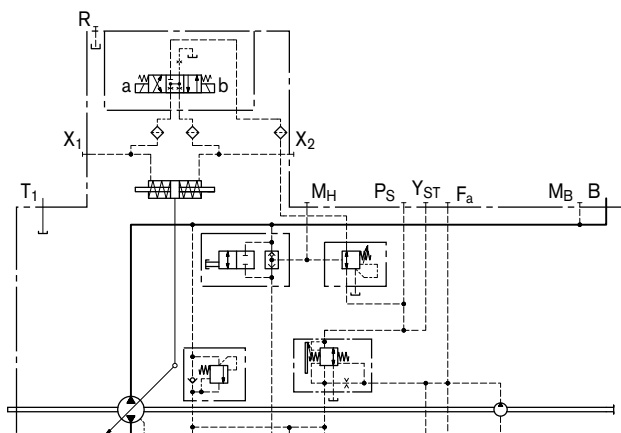

DA control valve fixed setting and braking inch valve mounted (4, 5) (only for pumps with DA control module)

Version with pressure reducing valve

Any reduction of the control pressure possible, independently of the drive speed via hydraulic control (port Z).

Version 4

Control at port Z by means of brake fluid according to ISO 4925 (no mineral oil), from the vehicle braking system (hydraulically linked with the service brake).

Version 5

Control at port Z by means of brake fluid based on mineral oil.

Schematic

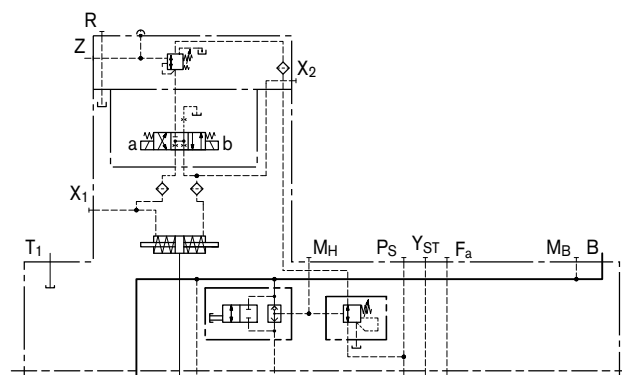

DA control valve fixed setting, ports for pilot control device as inch valve (6)

Any reduction of the control pressure possible, independently of the drive speed is achieved by the mechanical actuation of the pilot control device.

The pilot control device is installed separately from the pump (for example in the driver's cabin) and connected to the pump by two hydraulic control lines via ports P_S and Y_{ST} .

A suitable pilot control device must be ordered separately and is not included in the delivery contents.

Detailed information is available from our sales department and on the Internet at www.boschrexroth.com/da-control. Use our computer program to work out the input design that meets your needs. All DA applications must be approved by a Bosch Rexroth application engineer.

Schematic

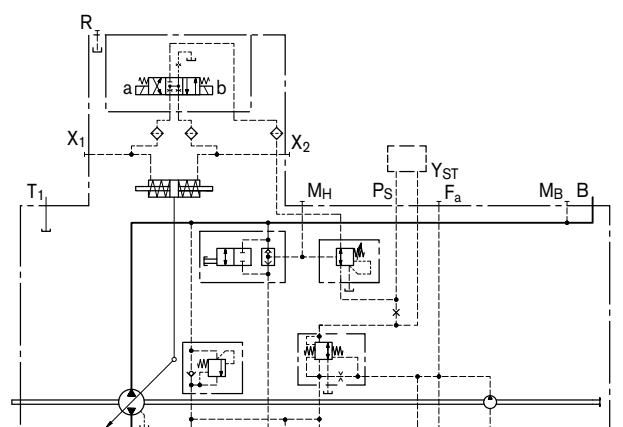

HT – Hydraulic control, direct controlled

With the direct hydraulic control (HT), the output flow of the pump is controlled by a hydraulic control pressure, applied directly to the stroking piston through either port X₁ or X₂.

Flow direction is determined by which control pressure port is pressurized (refer to table below).

Pump displacement is infinitely variable and proportional to the applied control pressure, but is also influenced by system pressure and pump drive speed.

In order to use the optional built-in pressure cut-off valve, port Y_{HT} must be used as the control pressure source for the selected control module. See page 53 for a description of the pressure cut-off function.

Maximum permissible control pressure: 580 psi (40 bar)

Use of the HT control requires a review of the engine and vehicle parameters to ensure that the pump is set up correctly. We recommend that all HT applications be reviewed by a Bosch Rexroth application engineer.

If the pump is also equipped with a DA control valve (see page 17), automotive operation is possible for travel drives.

Schematic

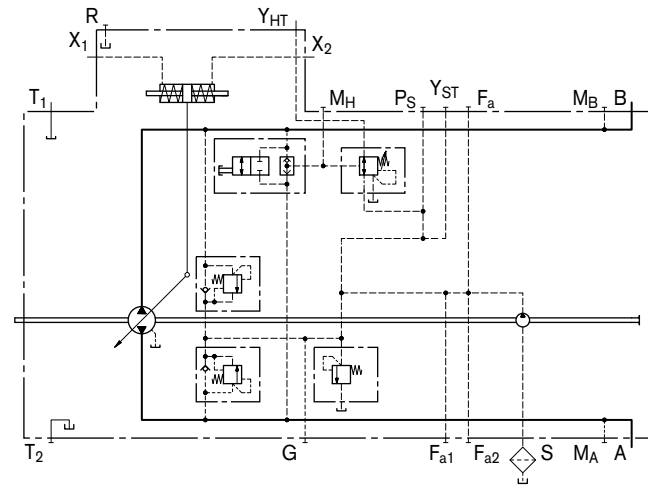

Correlation

Direction of rotation - Control - Flow direction

	Control pressure	Flow direction	Operating pressure	
Direction of rotation	cw	X ₁	B to A	M _A
		X ₂	A to B	M _B
	ccw	X ₁	A to B	M _B
		X ₂	B to A	M _A

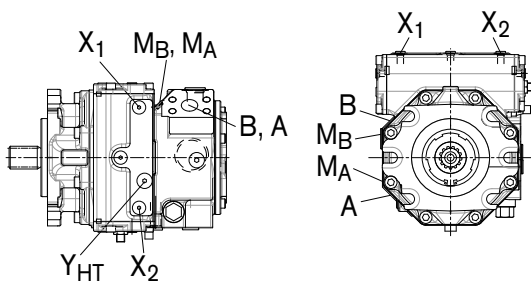

EV – Electric control, direct controlled

With the direct electric control (EV), the output flow of the pump is infinitely variable between 0 to 100 %, controlled by the control pressure of the pressure reducing valve. This control pressure level is proportional to the electric current, applied to the solenoid of the pressure reducing valve. This control pressure is then connected directly to the stroking cylinder of the pump by energizing either switching solenoid a or b on the EV control module, which determines the direction of the pump flow. The resulting pump displacement at a certain control pressure is also influenced by pump drive speed and operating pressure.

Technical data, pressure reducing valve

	EV1	EV2
Voltage	12 V	24 V
Control current		
Beginning of control at $V_g = 0$	515 mA	255 mA
End of control at $V_{g\ max}$	990 mA	495 mA
Limiting current	1.54 A	0.77 A
Nominal resistance (at 68 °F (20 °C))	5.5 Ω	22.7 Ω
Dither frequency	100 Hz	100 Hz
Duty cycle	100 %	100 %

Type of protection see connector design page 60

Depending on the operating point, the specified values may vary slightly.

The following electronic controllers and amplifiers are available for controlling the proportional solenoids:

- BODAS controller RC
 - Series 20 _____ RE 95200
 - Series 21 _____ RE 95201
 - Series 22 _____ RE 95202
 - Series 30 _____ RE 95203, RE 95204
 and application software
- Analog amplifier RA _____ RE 95230

Further information can also be found on the Internet at www.boschrexroth.com/mobile-electronics.

Technical data, solenoid

	EV1	EV2
Voltage	12 V (±20 %)	24 V (±20 %)
Neutral position $V_g = 0$	de-energized	de-energized
Displacement V_g	energized	energized
Nominal resistance (at 68 °F (20 °C))	5.5 Ω	21.7 Ω
Nominal power	26.2 W	26.5 W
Minimum required current	1.32 A	0.67 A
Duty cycle	100 %	100 %

Type of protection see connector design page 60

Standard

Switching solenoid without manual override.

On request

Switching solenoid with manual override and spring return.

Correlation

Direction of rotation - Control - Flow direction

	Actuation of solenoid	Control pressure	Flow direction	Operating pressure
Direction of rotation cw	a	X_2	A to B	M_B
	b	X_1	B to A	M_A
Direction of rotation ccw	a	X_2	B to A	M_A
	b	X_1	A to B	M_B

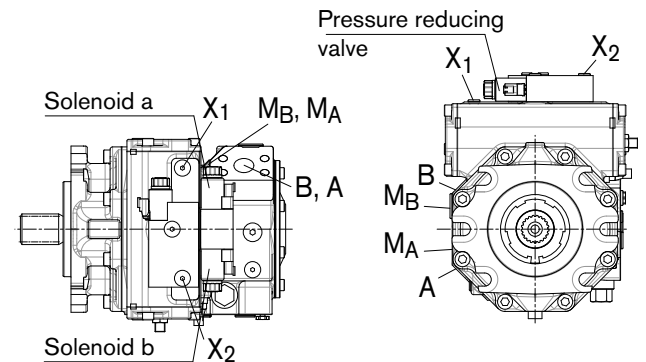

Schematic

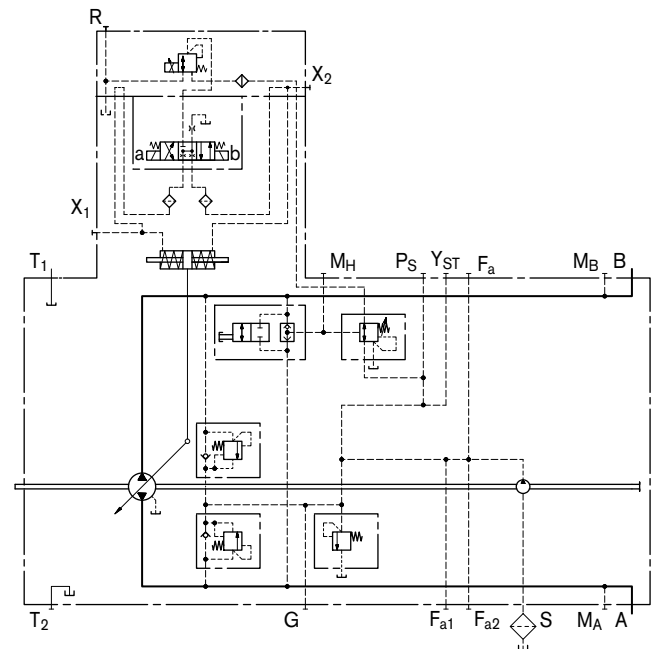

Dimensions size 45

Before finalizing your design, request a binding installation drawing. Dimensions in inch (mm).

EP – Proportional control electric

SAE flange ports A and B, 45° left (viewed on drive shaft)¹⁾

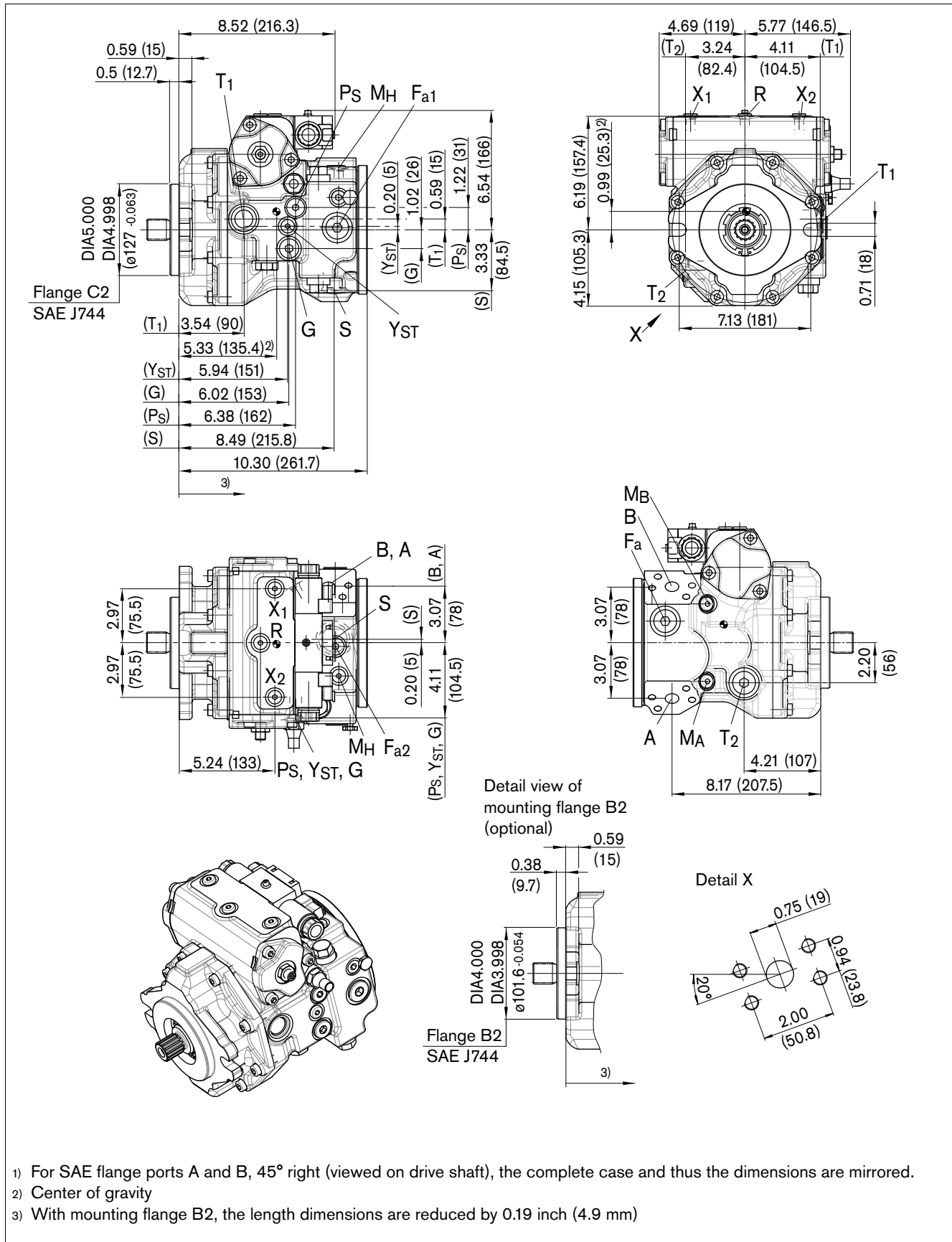

1) For SAE flange ports A and B, 45° right (viewed on drive shaft), the complete case and thus the dimensions are mirrored.

2) Center of gravity

3) With mounting flange B2, the length dimensions are reduced by 0.19 inch (4.9 mm)

Dimensions size 45

Before finalizing your design, request a binding installation drawing. Dimensions in inch (mm).

Drive shafts

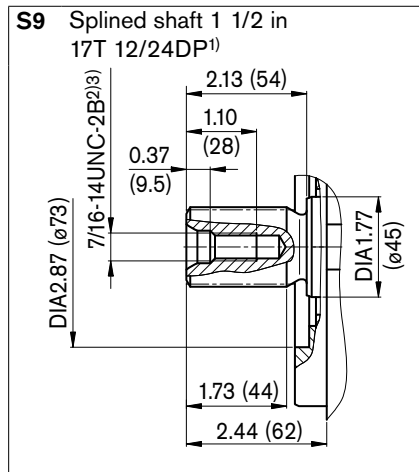
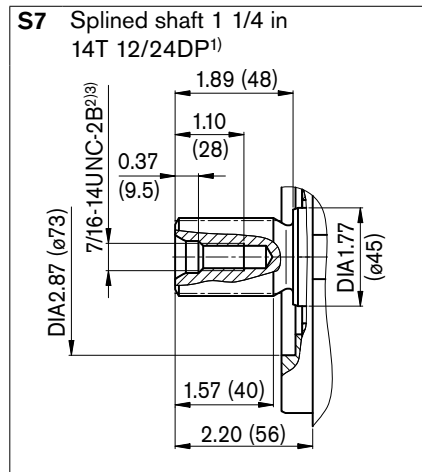

Ports

Designation	Port for	Standard	Size ³⁾	Maximum pressure [psi (bar)] ⁴⁾	State
A, B ¹⁰⁾	Service line Fastening thread A/B, screw grade 8 with hardened washer	SAE J518 ⁵⁾ ASME B1.1	3/4 in 3/8-16UNC; 0.83 (21) deep	7250 (500)	O
S	Suction line	ISO 11926 ⁹⁾	1 5/16-12UN-2B; 0.79 (20) deep	75 (5)	O ⁶⁾
T ₁	Drain line	ISO 11926 ⁹⁾	1 1/16-12UN-2B; 0.79 (20) deep	45 (3)	O ⁷⁾
T ₂	Drain line	ISO 11926 ⁹⁾	1 1/16-12UN-2B; 0.79 (20) deep	45 (3)	X ⁷⁾
R	Air bleed	ISO 11926 ⁹⁾	9/16-18UNF-2B; 0.51 (13) deep	45 (3)	X
X ₁ , X ₂	Control pressure (upstream of orifice)	ISO 11926 ⁹⁾	9/16-18UNF-2B; 0.51 (13) deep	580 (40)	X
X ₁ , X ₂	Control pressure (upstream of orifice, HT only)	ISO 11926 ⁹⁾	9/16-18UNF-2B; 0.51 (13) deep	580 (40)	O
X ₃ , X ₄ ⁸⁾	Stroking chamber pressure	ISO 11926 ⁹⁾	9/16-18UNF-2B; 0.51 (13) deep	580 (40)	X
G	Boost pressure	ISO 11926 ⁹⁾	7/8-14UNF-2B; 0.67 (17) deep	580 (40)	X
P _S	Pilot pressure, inlet	ISO 11926 ⁹⁾	3/4-16UNF-2B; 0.59 (15) deep	580 (40)	X
P _S	Pilot pressure, inlet (DA6 only)	ISO 11926 ⁹⁾	3/4-16UNF-2B; 0.59 (15) deep	580 (40)	O
Y _{ST}	Pilot pressure, outlet	ISO 11926 ⁹⁾	9/16-18UNF-2B; 0.51 (13) deep	580 (40)	X
Y _{ST}	Pilot pressure, outlet (DA6 only)	ISO 11926 ⁹⁾	9/16-18UNF-2B; 0.51 (13) deep	580 (40)	O
Y _{HT}	Pilot pressure, outlet (HT only)	ISO 11926 ⁹⁾	9/16-18UNF-2B; 0.51 (13) deep	580 (40)	O
M _A , M _B	Measuring pressure A, B	ISO 11926 ⁹⁾	9/16-18UNF-2B; 0.51 (13) deep	7250 (500)	X
M _H	Measuring high pressure	ISO 11926 ⁹⁾	9/16-18UNF-2B; 0.51 (13) deep	7250 (500)	X
F _a ¹¹⁾	Boost pressure	ISO 11926 ⁹⁾	1 1/16-12UN-2B; 0.79 (20) deep	580 (40)	X
F _{a1} ¹¹⁾	Boost pressure	ISO 11926 ⁹⁾	No specification	580 (40)	X
F _{a2} ¹¹⁾	Boost pressure	ISO 11926 ⁹⁾	No specification	580 (40)	X
Y ₁ , Y ₂	Pilot signal (HP only)	ISO 11926 ⁹⁾	9/16-18UNF-2B; 0.51 (13) deep	580 (40)	O
Z	Inch signal (DA4 and 5 only)	ISO 11926 ⁹⁾	3/8-24UNF-2B; 0.39 (10) deep	580 (40)	O

1) ANSI B92.1a, 30° pressure angle, flat root, side fit, tolerance class 5

2) Thread according to ASME B1.1

3) Observe the general instructions on page 66 for the maximum tightening torques.

4) Momentary pressure spikes may occur depending on the application. Keep this in mind when selecting measuring devices and fittings.

5) Only dimensions according to SAE J518.

6) Plugged with external supply option (Code E)

7) Depending on installation position, T₁ or T₂ must be connected (see also installation instructions on pages 63 and 64).

8) Optional, see page 55

9) The spot face can be deeper than specified in the appropriate standard.

10) For the maximum utilization of pressure, only grade 8 screws and hardened washers are to be used to tighten the SAE flange shells.

11) No standard ports, subject to change, please contact before use

O = Must be connected (plugged on delivery)

X = Plugged (in normal operation)

Dimensions size 45

Before finalizing your design, request a binding installation drawing. Dimensions in inch (mm).

DA – control valves

Version 2, 3 – mechanically adjustable with position lever

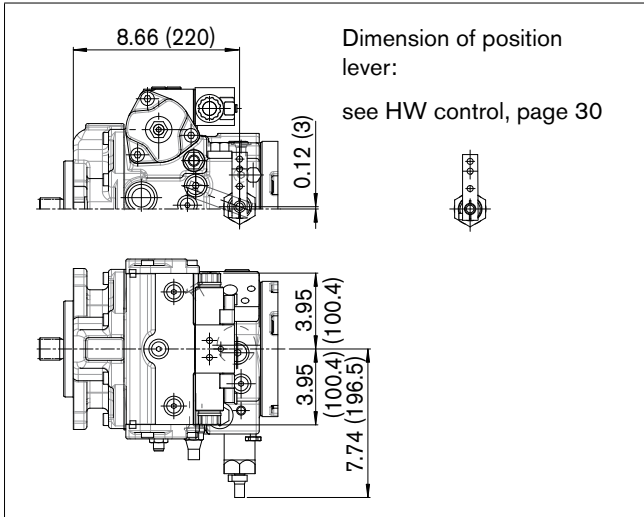

Dimensions size 45

Before finalizing your design, request a binding installation drawing. Dimensions in inch (mm).

Dimensions size 65

Before finalizing your design, request a binding installation drawing. Dimensions in inch (mm).

EP – Proportional control electric

SAE flange ports A and B, 45° left (viewed on drive shaft)¹⁾

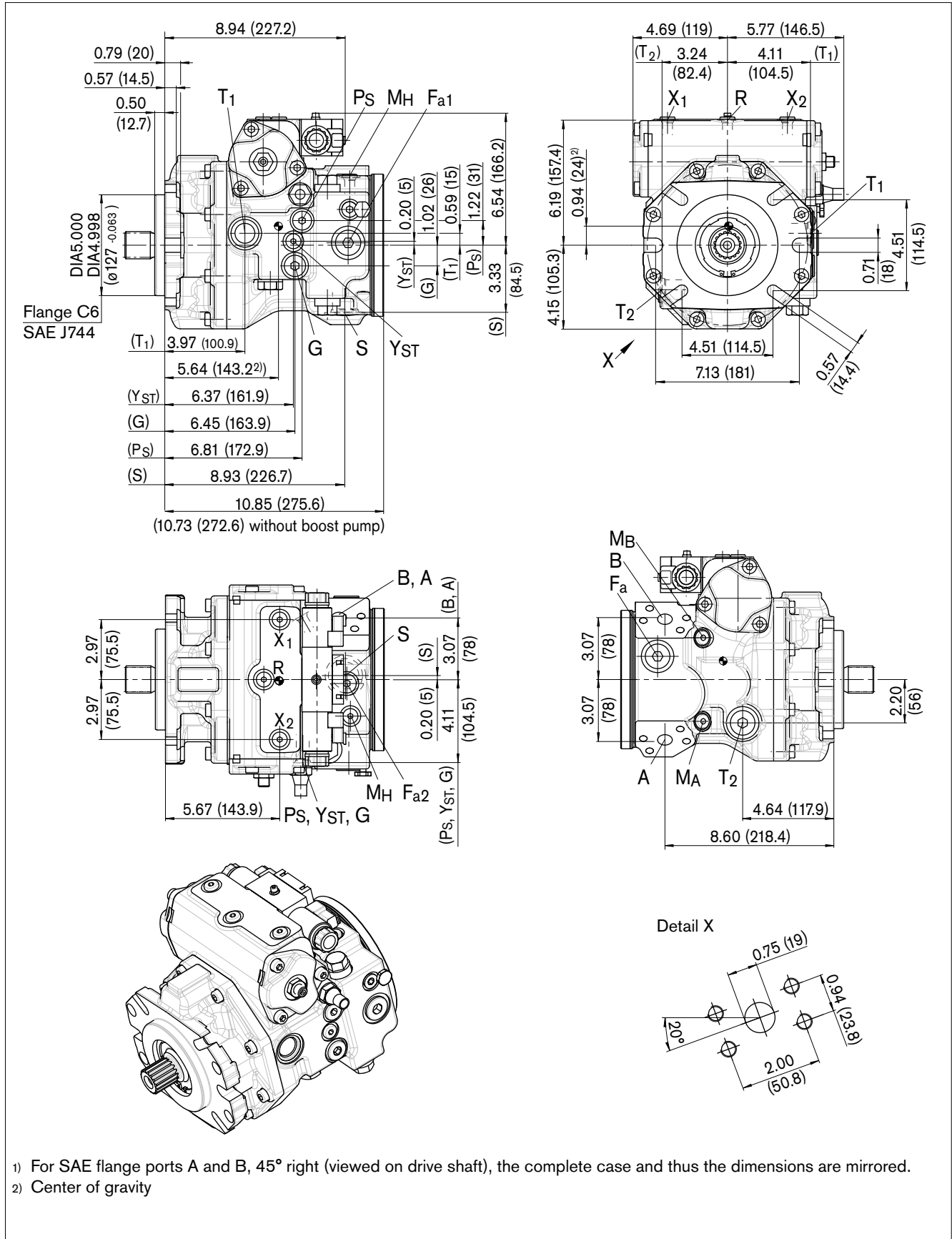

1) For SAE flange ports A and B, 45° right (viewed on drive shaft), the complete case and thus the dimensions are mirrored.
 2) Center of gravity

Dimensions size 65

Before finalizing your design, request a binding installation drawing. Dimensions in inch (mm).

Drive shafts

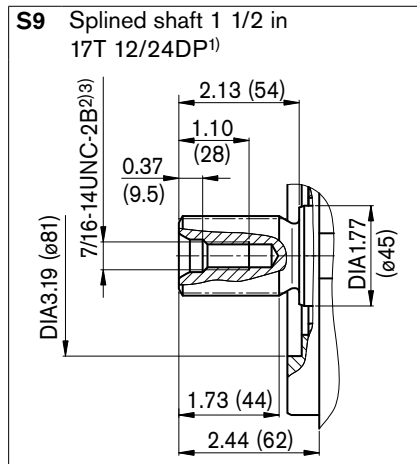
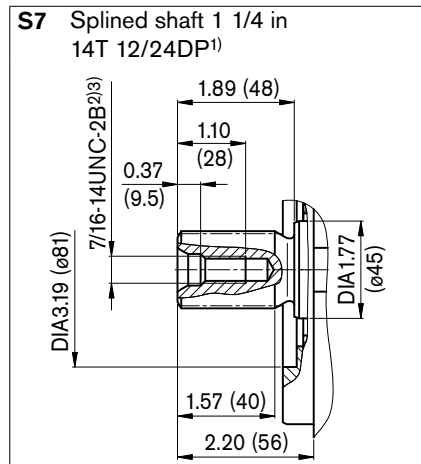

Ports

Designation	Port for	Standard	Size ³⁾	Maximum pressure [psi (bar)] ⁴⁾	State
A, B ¹⁰⁾	Service line Fastening thread A/B, screw grade 8 with hardened washer	SAE J518 ⁵⁾ ASME B1.1	3/4 in 3/8-16UNC; 0.83 (21) deep	7250 (500)	O
S	Suction line	ISO 11926 ⁹⁾	1 5/16-12UN-2B; 0.79 (20) deep	75 (5)	O ⁶⁾
T ₁	Drain line	ISO 11926 ⁹⁾	1 1/16-12UN-2B; 0.79 (20) deep	45 (3)	O ⁷⁾
T ₂	Drain line	ISO 11926 ⁹⁾	1 1/16-12UN-2B; 0.79 (20) deep	45 (3)	X ⁷⁾
R	Air bleed	ISO 11926 ⁹⁾	9/16-18UNF-2B; 0.51 (13) deep	45 (3)	X
X ₁ , X ₂	Control pressure (upstream of orifice)	ISO 11926 ⁹⁾	9/16-18UNF-2B; 0.51 (13) deep	580 (40)	X
X ₁ , X ₂	Control pressure (upstream of orifice, HT only)	ISO 11926 ⁹⁾	9/16-18UNF-2B; 0.51 (13) deep	580 (40)	O
X ₃ , X ₄ ⁸⁾	Stroking chamber pressure	ISO 11926 ⁹⁾	9/16-18UNF-2B; 0.51 (13) deep	580 (40)	X
G	Boost pressure	ISO 11926 ⁹⁾	7/8-14UNF-2B; 0.67 (17) deep	580 (40)	X
P _S	Pilot pressure, inlet	ISO 11926 ⁹⁾	3/4-16UNF-2B; 0.59 (15) deep	580 (40)	X
P _S	Pilot pressure, inlet (DA6 only)	ISO 11926 ⁹⁾	3/4-16UNF-2B; 0.59 (15) deep	580 (40)	O
Y _{ST}	Pilot pressure, outlet	ISO 11926 ⁹⁾	9/16-18UNF-2B; 0.51 (13) deep	580 (40)	X
Y _{ST}	Pilot pressure, outlet (DA6 only)	ISO 11926 ⁹⁾	9/16-18UNF-2B; 0.51 (13) deep	580 (40)	O
Y _{HT}	Pilot pressure, outlet (HT only)	ISO 11926 ⁹⁾	9/16-18UNF-2B; 0.51 (13) deep	580 (40)	O
M _A , M _B	Measuring pressure A, B	ISO 11926 ⁹⁾	9/16-18UNF-2B; 0.51 (13) deep	7250 (500)	X
M _H	Measuring high pressure	ISO 11926 ⁹⁾	9/16-18UNF-2B; 0.51 (13) deep	7250 (500)	X
F _a ¹¹⁾	Boost pressure	ISO 11926 ⁹⁾	1 1/16-12UN-2B; 0.79 (20) deep	580 (40)	X
F _{a1} ¹¹⁾	Boost pressure	ISO 11926 ⁹⁾	No specification	580 (40)	X
F _{a2} ¹¹⁾	Boost pressure	ISO 11926 ⁹⁾	No specification	580 (40)	X
Y ₁ , Y ₂	Pilot signal (HP only)	ISO 11926 ⁹⁾	9/16-18UNF-2B; 0.51 (13) deep	580 (40)	O
Z	Inch signal (DA4 and 5 only)	ISO 11926 ⁹⁾	3/8-24UNF-2B; 0.39 (10) deep	580 (40)	O

1) ANSI B92.1a, 30° pressure angle, flat root, side fit, tolerance class 5

2) Thread according to ASME B1.1

3) Observe the general instructions on page 66 for the maximum tightening torques.

4) Momentary pressure spikes may occur depending on the application. Keep this in mind when selecting measuring devices and fittings.

5) Only dimensions according to SAE J518.

6) Plugged with external supply option (Code E)

7) Depending on installation position, T₁ or T₂ must be connected (see also installation instructions on pages 63 and 64).

8) Optional, see page 55

9) The spot face can be deeper than specified in the appropriate standard.

10) For the maximum utilization of pressure, only grade 8 screws and hardened washers are to be used to tighten the SAE flange shells.

11) No standard ports, subject to change, please contact before use

O = Must be connected (plugged on delivery)

X = Plugged (in normal operation)

Dimensions size 65

Before finalizing your design, request a binding installation drawing. Dimensions in inch (mm).

DA – control valves

Version 1 – fixed setting

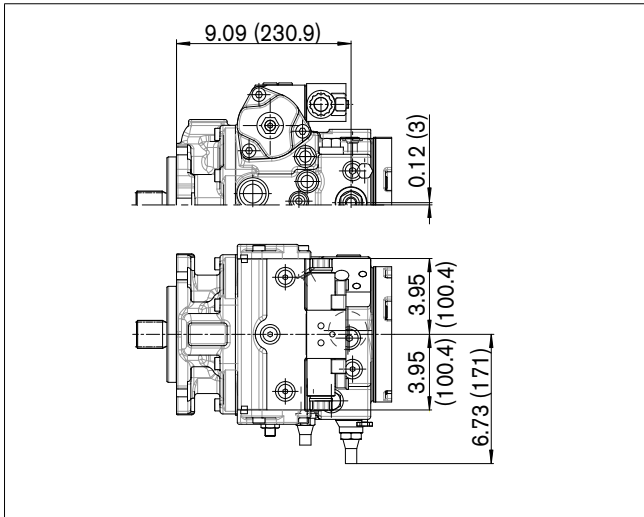

Version 2, 3 – mechanically adjustable with position lever

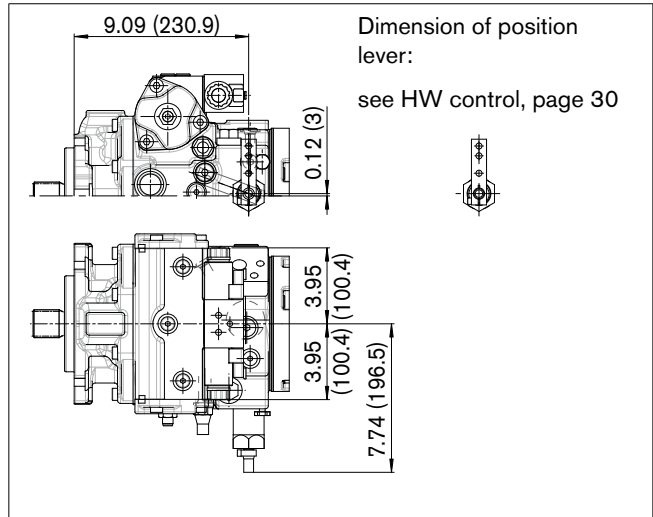

Dimensions size 65

Before finalizing your design, request a binding installation drawing. Dimensions in inch (mm).

Dimensions size 85

Before finalizing your design, request a binding installation drawing. Dimensions in inch (mm).

EP – Proportional control electric

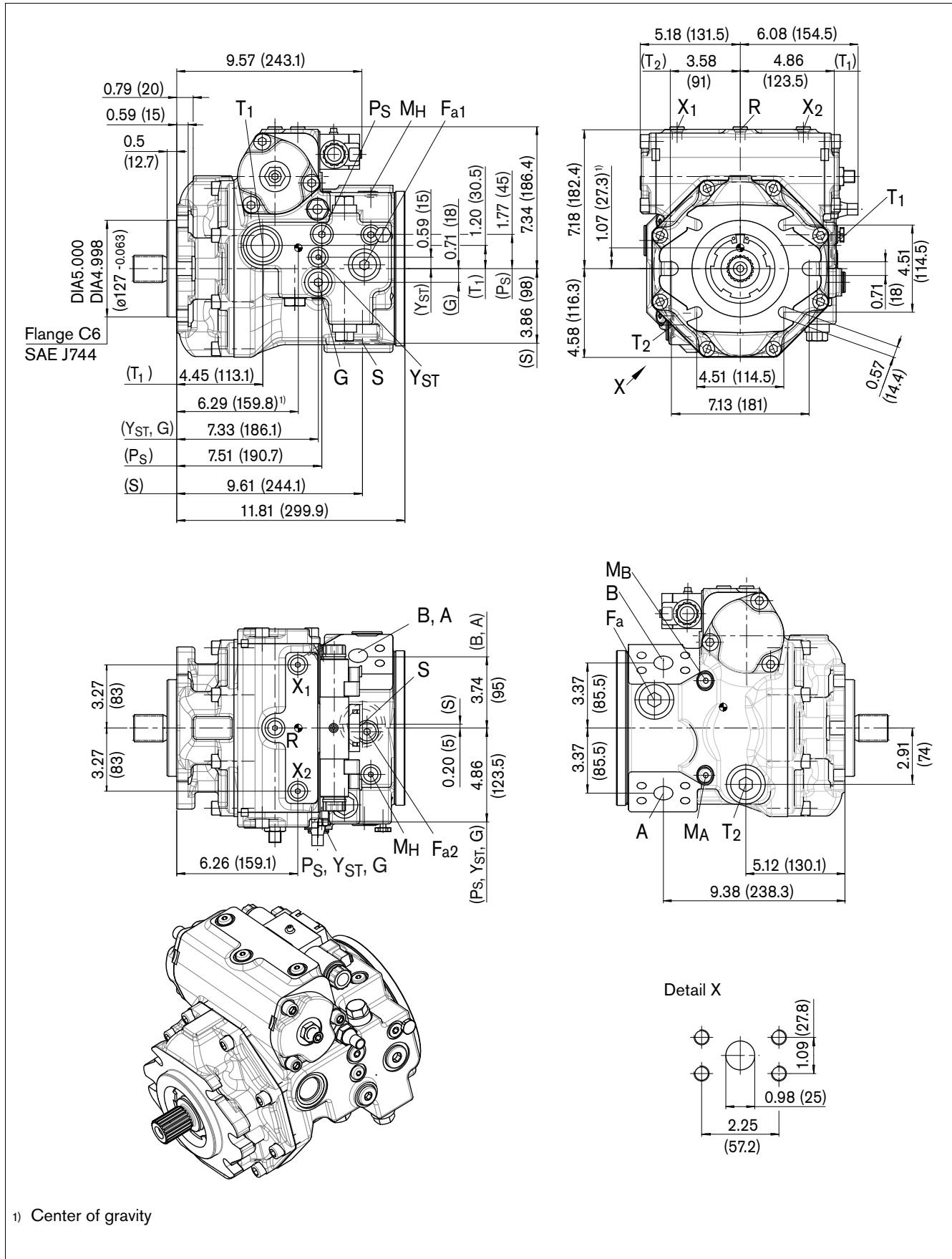

Dimensions size 85

Before finalizing your design, request a binding installation drawing. Dimensions in inch (mm).

Drive shafts

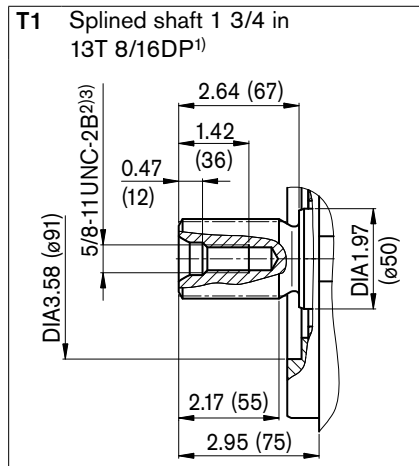
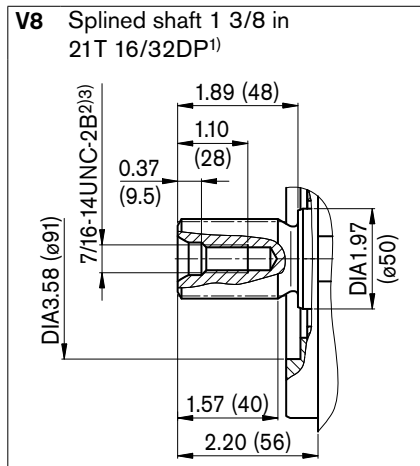

Ports

Designation	Port for	Standard	Size ³⁾	Maximum pressure [psi (bar)] ⁴⁾	State
A, B ¹⁰⁾	Service line Fastening thread A/B, screw grade 8 with hardened washer	SAE J518 ⁵⁾ ASME B.1.1	1 in 7/16-14UNC; 0.87 (22) deep	7250 (500)	O
S	Suction line	ISO 11926 ⁹⁾	1 5/8-12UN-2B; 0.79 (20) deep	75 (5)	O ⁶⁾
T ₁	Drain line	ISO 11926 ⁹⁾	1 5/16-12UN-2B; 0.79 (20) deep	45 (3)	O ⁷⁾
T ₂	Drain line	ISO 11926 ⁹⁾	1 5/16-12UN-2B; 0.79 (20) deep	45 (3)	X ⁷⁾
R	Air bleed	ISO 11926 ⁹⁾	9/16-18UNF-2B; 0.51 (13) deep	45 (3)	X
X ₁ , X ₂	Control pressure (upstream of orifice)	ISO 11926 ⁹⁾	9/16-18UNF-2B; 0.51 (13) deep	580 (40)	X
X ₁ , X ₂	Control pressure (upstream of orifice, HT only)	ISO 11926 ⁹⁾	9/16-18UNF-2B; 0.51 (13) deep	580 (40)	O
X ₃ , X ₄ ⁸⁾	Stroking chamber pressure	ISO 11926 ⁹⁾	9/16-18UNF-2B; 0.51 (13) deep	580 (40)	X
G	Boost pressure	ISO 11926 ⁹⁾	7/8-14UNF-2B; 0.67 (17) deep	580 (40)	X
P _S	Pilot pressure, inlet	ISO 11926 ⁹⁾	3/4-16UNF-2B; 0.59 (15) deep	580 (40)	X
P _S	Pilot pressure, inlet (DA6 only)	ISO 11926 ⁹⁾	3/4-16UNF-2B; 0.59 (15) deep	580 (40)	O
Y _{ST}	Pilot pressure, outlet	ISO 11926 ⁹⁾	9/16-18UNF-2B; 0.51 (13) deep	580 (40)	X
Y _{ST}	Pilot pressure, outlet (DA6 only)	ISO 11926 ⁹⁾	9/16-18UNF-2B; 0.51 (13) deep	580 (40)	O
Y _{HT}	Pilot pressure, outlet (HT only)	ISO 11926 ⁹⁾	9/16-18UNF-2B; 0.51 (13) deep	580 (40)	O
M _A , M _B	Measuring pressure A, B	ISO 11926 ⁹⁾	9/16-18UNF-2B; 0.51 (13) deep	7250 (500)	X
M _H	Measuring high pressure	ISO 11926 ⁹⁾	9/16-18UNF-2B; 0.51 (13) deep	7250 (500)	X
F _a ¹¹⁾	Boost pressure	ISO 11926 ⁹⁾	1 5/16-12UN-2B; 0.79 (20) deep	580 (40)	X
F _{a1} ¹¹⁾	Boost pressure	ISO 11926 ⁹⁾	No specification	580 (40)	X
F _{a2} ¹¹⁾	Boost pressure	ISO 11926 ⁹⁾	No specification	580 (40)	X
Y ₁ , Y ₂	Pilot signal (HP only)	ISO 11926 ⁹⁾	9/16-18UNF-2B; 0.51 (13) deep	580 (40)	O
Z	Inch signal (DA4 and 5 only)	ISO 11926 ⁹⁾	3/8-24UNF-2B; 0.39 (10) deep	580 (40)	O

1) ANSI B92.1a, 30° pressure angle, flat root, side fit, tolerance class 5

2) Thread according to ASME B.1.1

3) Observe the general instructions on page 66 for the maximum tightening torques.

4) Momentary pressure spikes may occur depending on the application. Keep this in mind when selecting measuring devices and fittings.

5) Only dimensions according to SAE J518.

6) Plugged with external supply option (Code E)

7) Depending on installation position, T₁ or T₂ must be connected (see also installation instructions on pages 63 and 64).

8) Optional, see page 55

9) The spot face can be deeper than specified in the appropriate standard.

10) For the maximum utilization of pressure, only grade 8 screws and hardened washers are to be used to tighten the SAE flange shells.

11) No standard ports, subject to change, please contact before use

O = Must be connected (plugged on delivery)

X = Plugged (in normal operation)

Dimensions size 85

Before finalizing your design, request a binding installation drawing. Dimensions in inch (mm).

HP
Proportional control hydraulic, pilot-pressure related

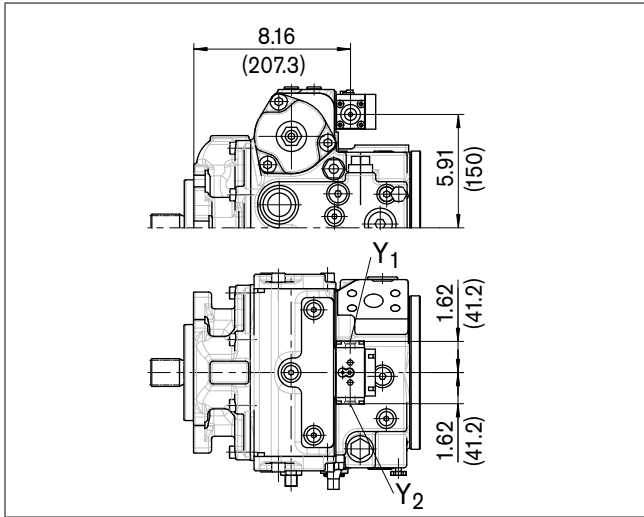

HW
Proportional control hydraulic, mechanical servo

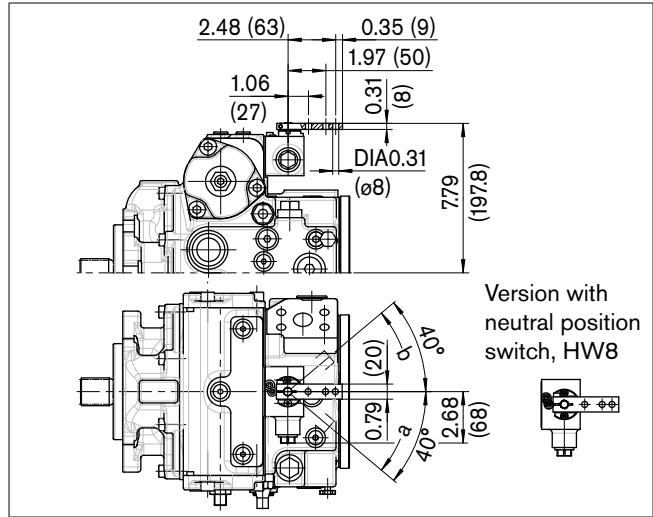

HT
Hydraulic control, direct controlled

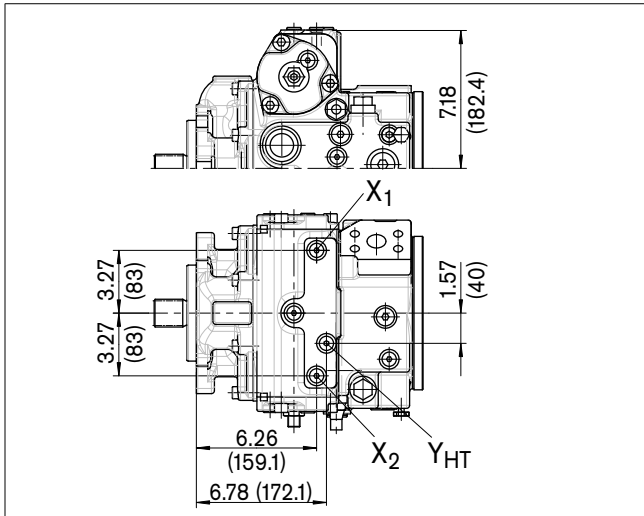

EZ
Two-point control electric

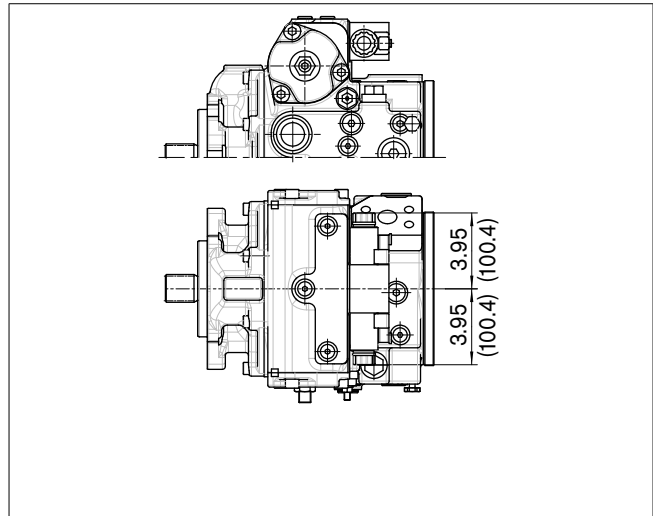

EV
Electric control, direct controlled

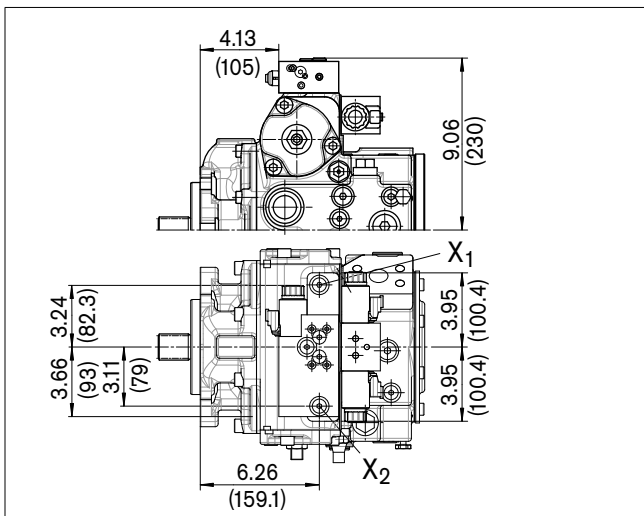

Dimensions size 85

Before finalizing your design, request a binding installation drawing. Dimensions in inch (mm).

DA – control valves

Version 1 – fixed setting

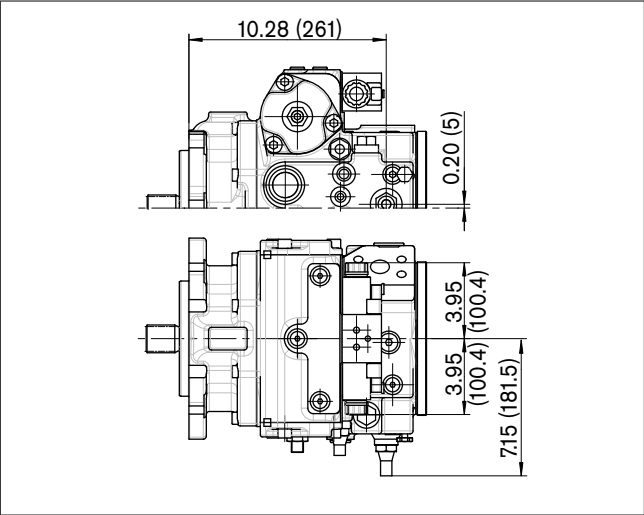

Dimensions size 110

Before finalizing your design, request a binding installation drawing. Dimensions in inch (mm).

EP – Proportional control electric

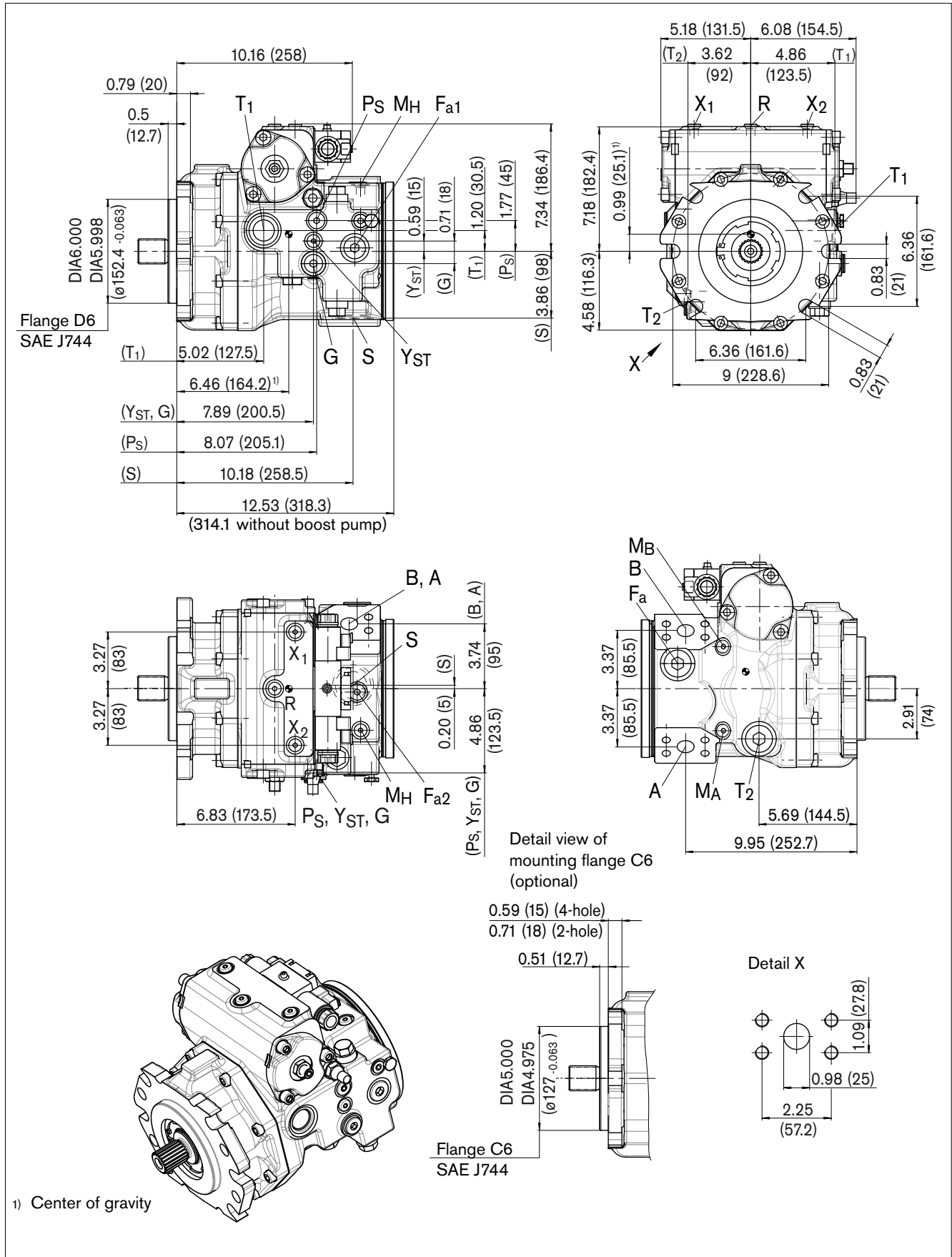

Dimensions size 110

Before finalizing your design, request a binding installation drawing. Dimensions in inch (mm).

Drive shafts

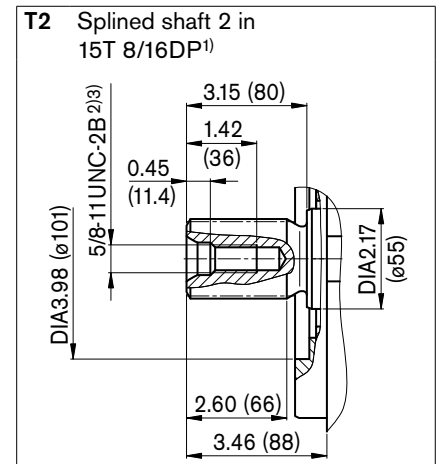
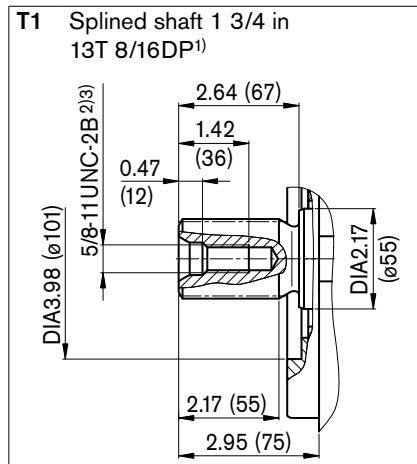
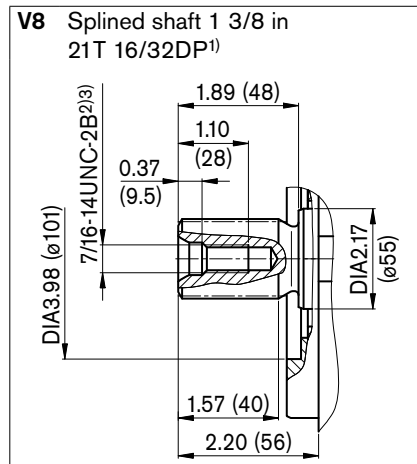

Ports

Designation	Port for	Standard	Size ³⁾	Maximum pressure [psi (bar)] ⁴⁾	State
A, B ¹⁰⁾	Service line Fastening thread A/B, screw grade 8 with hardened washer	SAE J518 ⁵⁾ ASME B1.1	1 in 7/16-14UNC; 0.87 (22) deep	7250 (500)	O
S	Suction line	ISO 11926 ⁹⁾	1 5/8-12UN-2B; 0.79 (20) deep	75 (5)	O ⁶⁾
T ₁	Drain line	ISO 11926 ⁹⁾	1 5/16-12UN-2B; 0.79 (20) deep	45 (3)	O ⁷⁾
T ₂	Drain line	ISO 11926 ⁹⁾	1 5/16-12UN-2B; 0.79 (20) deep	45 (3)	X ⁷⁾
R	Air bleed	ISO 11926 ⁹⁾	9/16-18UNF-2B; 0.51 (13) deep	45 (3)	X
X ₁ , X ₂	Control pressure (upstream of orifice)	ISO 11926 ⁹⁾	9/16-18UNF-2B; 0.51 (13) deep	580 (40)	X
X ₁ , X ₂	Control pressure (upstream of orifice, HT only)	ISO 11926 ⁹⁾	9/16-18UNF-2B; 0.51 (13) deep	580 (40)	O
X ₃ , X ₄ ⁸⁾	Stroking chamber pressure	ISO 11926 ⁹⁾	9/16-18UNF-2B; 0.51 (13) deep	580 (40)	X
G	Boost pressure	ISO 11926 ⁹⁾	7/8-14UNF-2B; 0.67 (17) deep	580 (40)	X
P _S	Pilot pressure, inlet	ISO 11926 ⁹⁾	3/4-16UNF-2B; 0.59 (15) deep	580 (40)	X
P _S	Pilot pressure, inlet (DA6 only)	ISO 11926 ⁹⁾	3/4-16UNF-2B; 0.59 (15) deep	580 (40)	O
Y _{ST}	Pilot pressure, outlet	ISO 11926 ⁹⁾	9/16-18UNF-2B; 0.51 (13) deep	580 (40)	X
Y _{ST}	Pilot pressure, outlet (DA6 only)	ISO 11926 ⁹⁾	9/16-18UNF-2B; 0.51 (13) deep	580 (40)	O
Y _{HT}	Pilot pressure, outlet (HT only)	ISO 11926 ⁹⁾	9/16-18UNF-2B; 0.51 (13) deep	580 (40)	O
M _A , M _B	Measuring pressure A, B	ISO 11926 ⁹⁾	9/16-18UNF-2B; 0.51 (13) deep	7250 (500)	X
M _H	Measuring high pressure	ISO 11926 ⁹⁾	9/16-18UNF-2B; 0.51 (13) deep	7250 (500)	X
F _a ¹¹⁾	Boost pressure	ISO 11926 ⁹⁾	1 5/16-12UN-2B; 0.79 (20) deep	580 (40)	X
F _{a1} ¹¹⁾	Boost pressure	ISO 11926 ⁹⁾	No specification	580 (40)	X
F _{a2} ¹¹⁾	Boost pressure	ISO 11926 ⁹⁾	No specification	580 (40)	X
Y ₁ , Y ₂	Pilot signal (HP only)	ISO 11926 ⁹⁾	9/16-18UNF-2B; 0.51 (13) deep	580 (40)	O
Z	Inch signal (DA4 and 5 only)	ISO 11926 ⁹⁾	3/8-24UNF-2B; 0.39 (10) deep	580 (40)	O

1) ANSI B92.1a, 30° pressure angle, flat root, side fit, tolerance class 5

2) Thread according to ASME B1.1

3) Observe the general instructions on page 66 for the maximum tightening torques.

4) Momentary pressure spikes may occur depending on the application. Keep this in mind when selecting measuring devices and fittings.

5) Only dimensions according to SAE J518.

6) Plugged with external supply option (Code E)

7) Depending on installation position, T₁ or T₂ must be connected (see also installation instructions on pages 63 and 64).

8) Optional, see page 55

9) The spot face can be deeper than specified in the appropriate standard.

10) For the maximum utilization of pressure, only grade 8 screws and hardened washers are to be used to tighten the SAE flange shells.

11) No standard ports, subject to change, please contact before use

O = Must be connected (plugged on delivery)

X = Plugged (in normal operation)

Dimensions size 110

Before finalizing your design, request a binding installation drawing. Dimensions in inch (mm).

HP
Proportional control hydraulic, pilot-pressure related

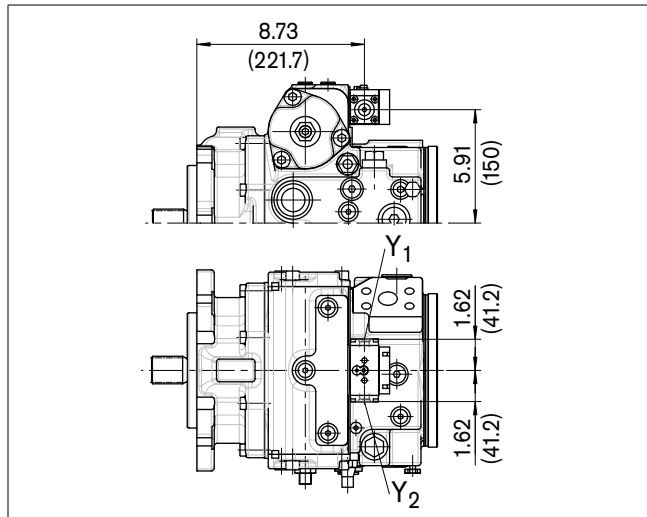

HW
Proportional control hydraulic, mechanical servo

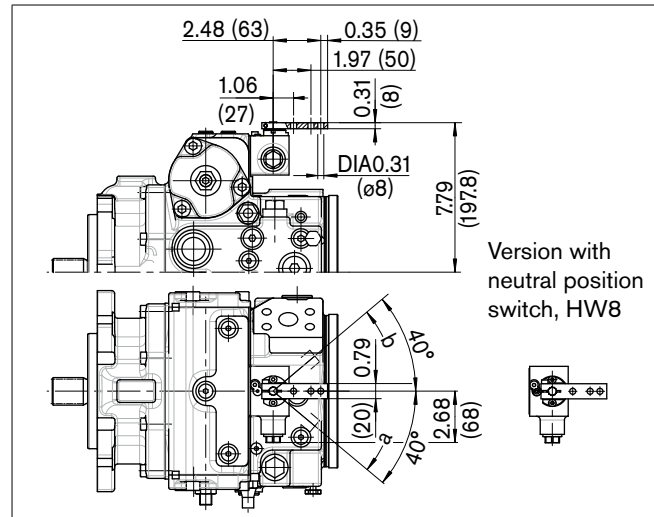

HT
Hydraulic control, direct controlled

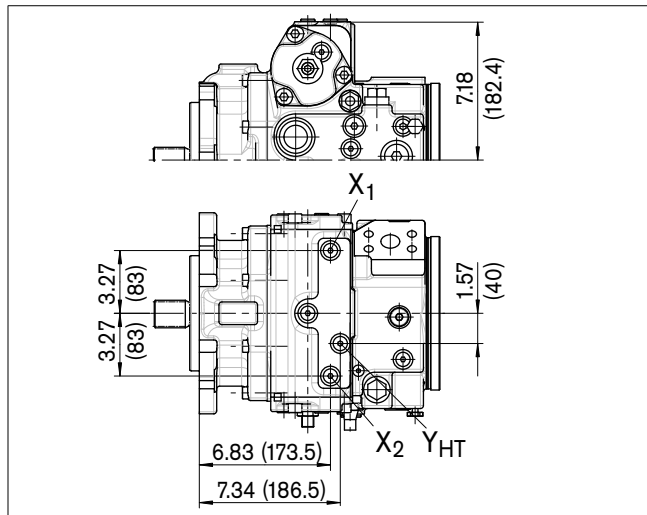

EZ
Two-point control electric

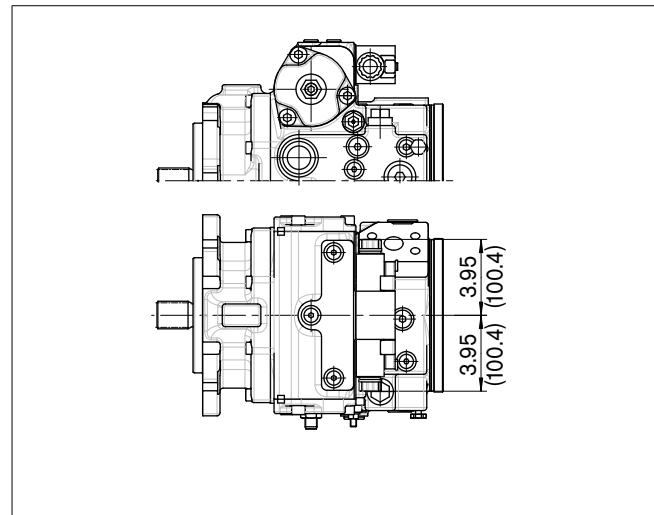

EV
Electric control, direct controlled

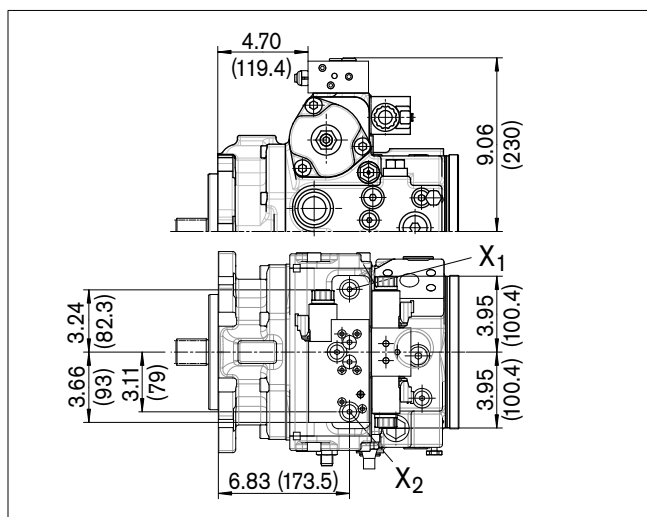

Dimensions size 110

Before finalizing your design, request a binding installation drawing. Dimensions in inch (mm).

DA – control valves

Version 1 – fixed setting

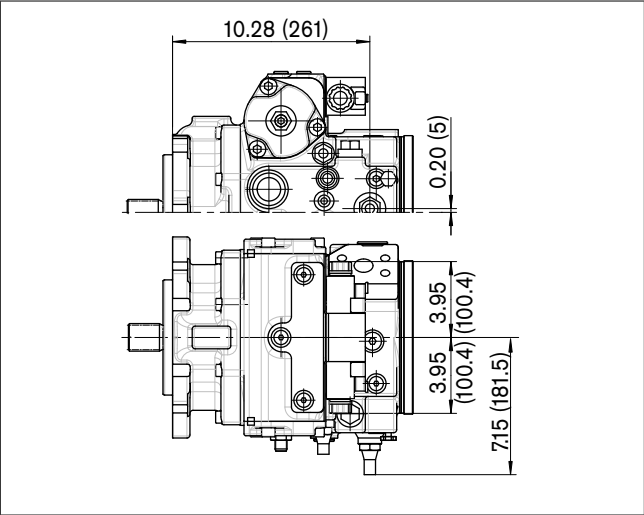

Dimensions size 145

Before finalizing your design, request a binding installation drawing. Dimensions in inch (mm).

EP – Proportional control electric

SAE flange ports A and B, 45° left (viewed on drive shaft)¹⁾

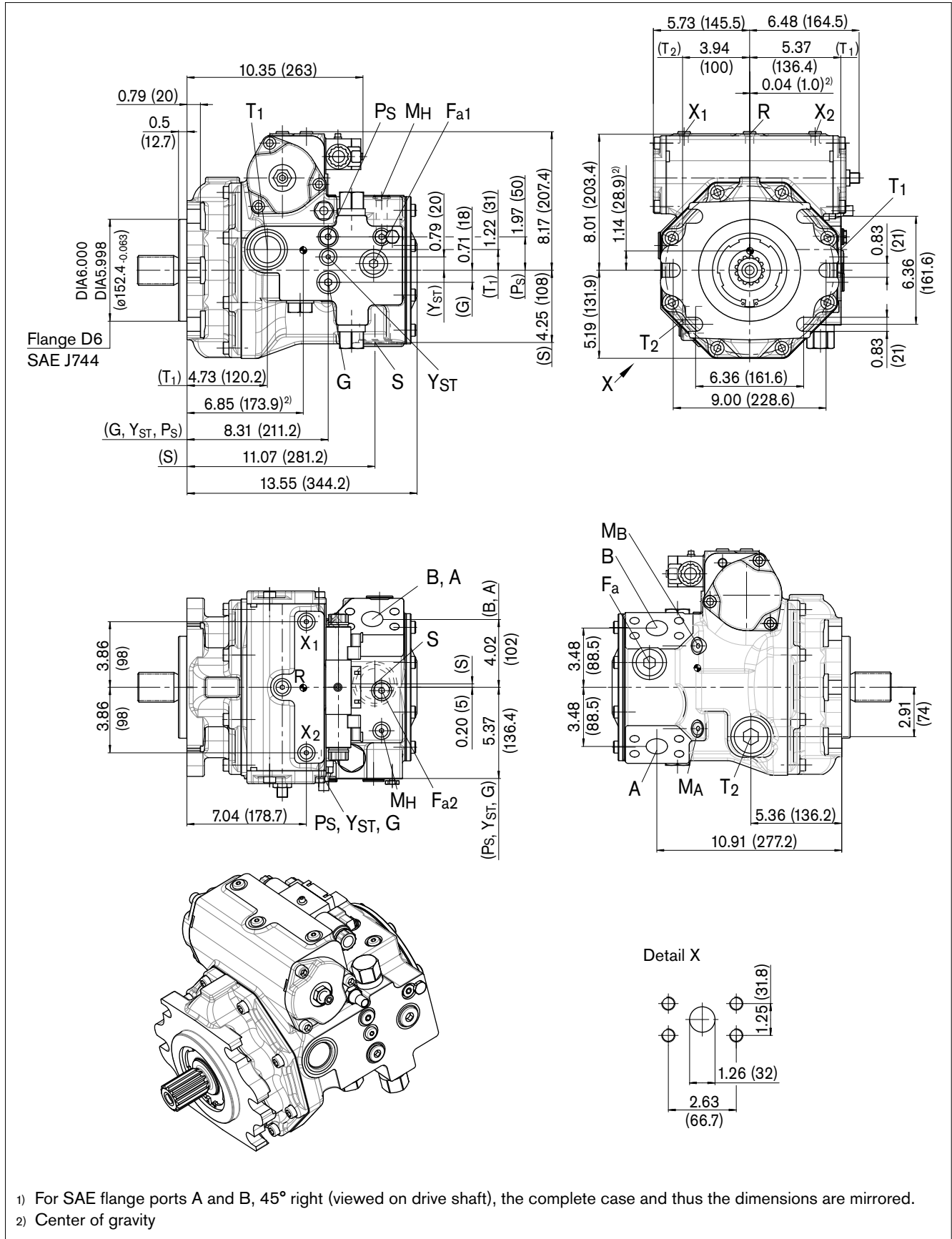

1) For SAE flange ports A and B, 45° right (viewed on drive shaft), the complete case and thus the dimensions are mirrored.
 2) Center of gravity

Dimensions size 145

Before finalizing your design, request a binding installation drawing. Dimensions in inch (mm).

Drive shafts

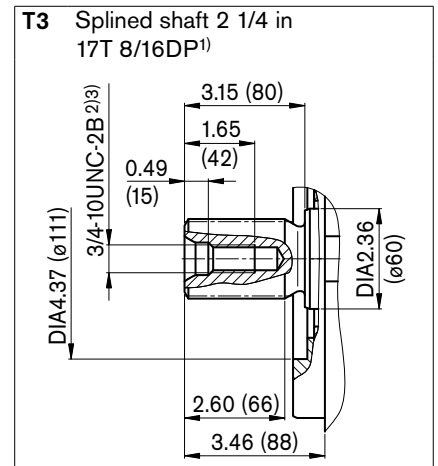
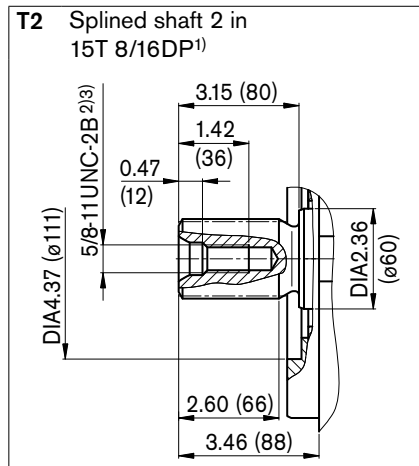
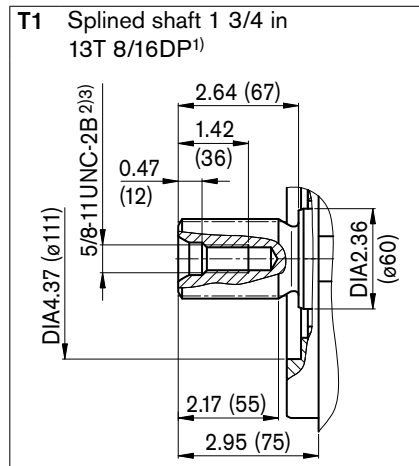

Ports

Designation	Port for	Standard	Size ³⁾	Maximum pressure [psi (bar)] ⁴⁾	State
A, B ¹⁰⁾	Service line Fastening thread A/B, screw grade 8 with hardened washer	SAE J518 ⁵⁾ ASME B1.1	1 1/4 in 1/2-13UNC; 0.75 (19) deep	7250 (500)	O
S	Suction line	ISO 11926 ⁹⁾	1 7/8-12UN-2B; 0.79 (20) deep	75 (5)	O ⁶⁾
T ₁	Drain line	ISO 11926 ⁹⁾	1 5/8-12UN-2B; 0.77 (19.5) deep	45 (3)	O ⁷⁾
T ₂	Drain line	ISO 11926 ⁹⁾	1 5/8-12UN-2B; 0.77 (19.5) deep	45 (3)	X ⁷⁾
R	Air bleed	ISO 11926 ⁹⁾	9/16-18UNF-2B; 0.51 (13) deep	45 (3)	X
X ₁ , X ₂	Control pressure (upstream of orifice)	ISO 11926 ⁹⁾	9/16-18UNF-2B; 0.51 (13) deep	580 (40)	X
X ₁ , X ₂	Control pressure (upstream of orifice, HT only)	ISO 11926 ⁹⁾	9/16-18UNF-2B; 0.51 (13) deep	580 (40)	O
X ₃ , X ₄ ⁸⁾	Stroking chamber pressure	ISO 11926 ⁹⁾	9/16-18UNF-2B; 0.51 (13) deep	580 (40)	X
G	Boost pressure	ISO 11926 ⁹⁾	7/8-14UNF-2B; 0.67 (17) deep	580 (40)	X
P _S	Pilot pressure, inlet	ISO 11926 ⁹⁾	3/4-16UNF-2B; 0.59 (15) deep	580 (40)	X
P _S	Pilot pressure, inlet (DA6 only)	ISO 11926 ⁹⁾	3/4-16UNF-2B; 0.59 (15) deep	580 (40)	O
Y _{ST}	Pilot pressure, outlet	ISO 11926 ⁹⁾	9/16-18UNF-2B; 0.51 (13) deep	580 (40)	X
Y _{ST}	Pilot pressure, outlet (DA6 only)	ISO 11926 ⁹⁾	9/16-18UNF-2B; 0.51 (13) deep	580 (40)	O
Y _{HT}	Pilot pressure, outlet (HT only)	ISO 11926 ⁹⁾	9/16-18UNF-2B; 0.51 (13) deep	580 (40)	O
M _A , M _B	Measuring pressure A, B	ISO 11926 ⁹⁾	9/16-18UNF-2B; 0.51 (13) deep	7250 (500)	X
M _H	Measuring high pressure	ISO 11926 ⁹⁾	9/16-18UNF-2B; 0.51 (13) deep	7250 (500)	X
F _a ¹¹⁾	Boost pressure	ISO 11926 ⁹⁾	1 5/16-12UN-2B; 0.79 (20) deep	580 (40)	X
F _{a1} ¹¹⁾	Boost pressure	ISO 11926 ⁹⁾	No specification	580 (40)	X
F _{a2} ¹¹⁾	Boost pressure	ISO 11926 ⁹⁾	No specification	580 (40)	X
Y ₁ , Y ₂	Pilot signal (HP only)	ISO 11926 ⁹⁾	9/16-18UNF-2B; 0.51 (13) deep	580 (40)	O
Z	Inch signal (DA4 and 5 only)	ISO 11926 ⁹⁾	3/8-24UNF-2B; 0.39 (10) deep	580 (40)	O

- 1) ANSI B92.1a, 30° pressure angle, flat root, side fit, tolerance class 5
 - 2) Thread according to ASME B1.1
 - 3) Observe the general instructions on page 66 for the maximum tightening torques.
 - 4) Momentary pressure spikes may occur depending on the application. Keep this in mind when selecting measuring devices and fittings.
 - 5) Only dimensions according to SAE J518.
 - 6) Plugged with external supply option (Code E)
 - 7) Depending on installation position, T₁ or T₂ must be connected (see also installation instructions on pages 63 and 64).
 - 8) Optional, see page 55
 - 9) The spot face can be deeper than specified in the appropriate standard.
 - 10) For the maximum utilization of pressure, only grade 8 screws and hardened washers are to be used to tighten the SAE flange shells.
 - 11) No standard ports, subject to change, please contact before use
- O = Must be connected (plugged on delivery) X = Plugged (in normal operation)

Dimensions size 145

Before finalizing your design, request a binding installation drawing. Dimensions in inch (mm).

HP

Proportional control hydraulic, pilot-pressure related

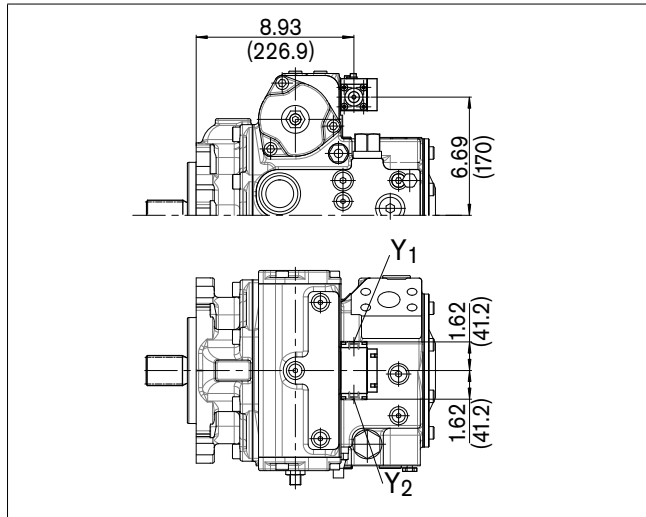

HW

Proportional control hydraulic, mechanical servo

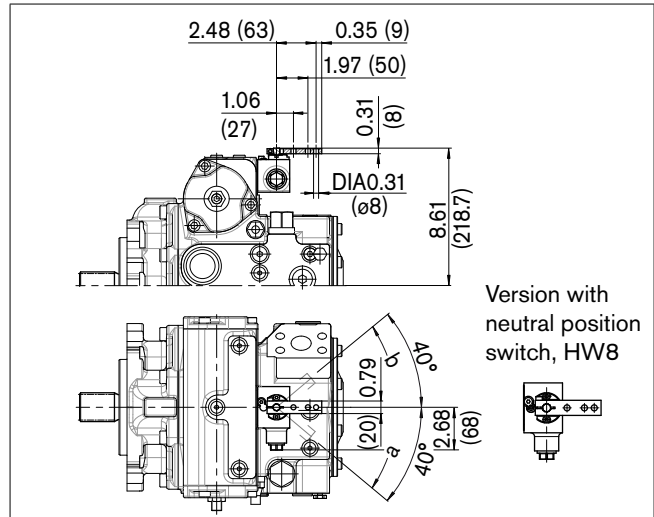

HT

Hydraulic control, direct controlled

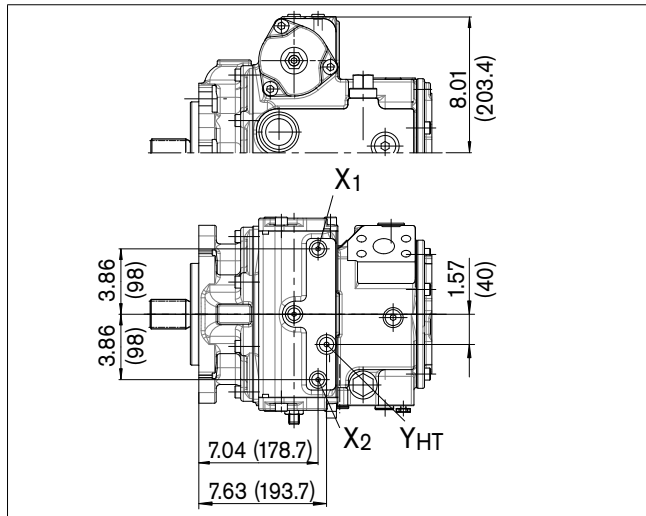

EZ

Two-point control electric

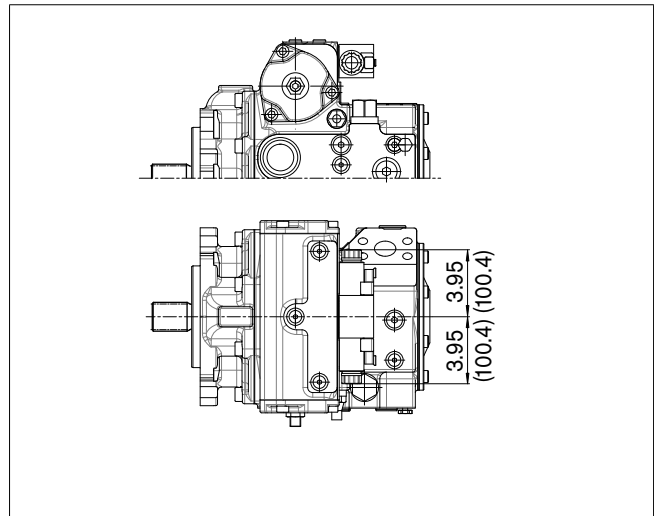

EV

Electric control, direct controlled

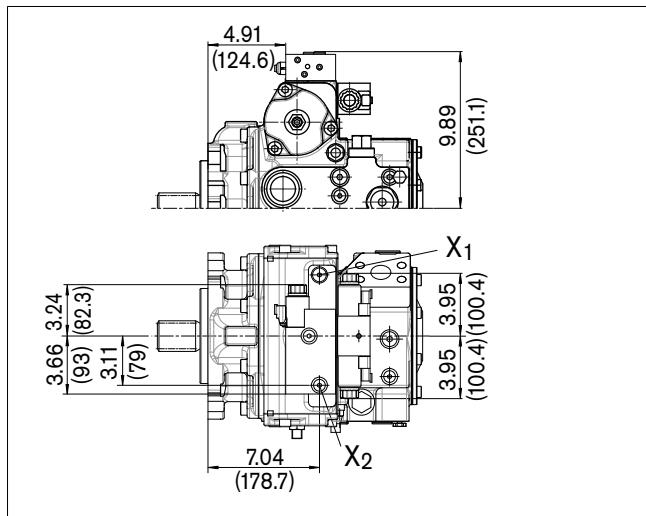

Dimensions size 145

Before finalizing your design, request a binding installation drawing. Dimensions in inch (mm).

DA – control valves

Version 1 – fixed setting

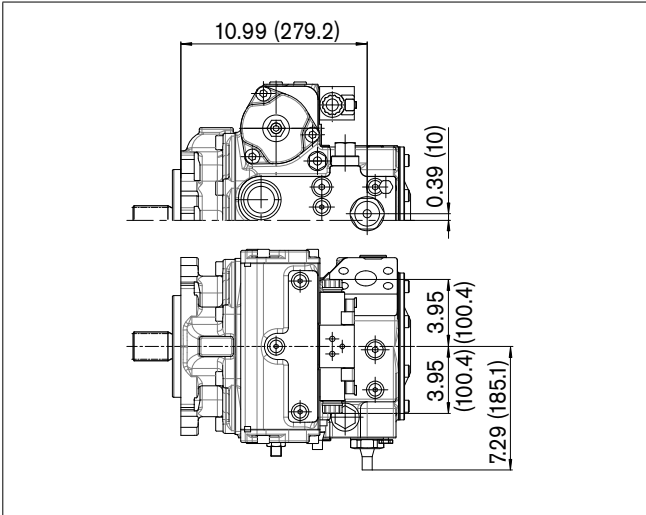

Version 4, 5 – fixed setting and inch valve mounted

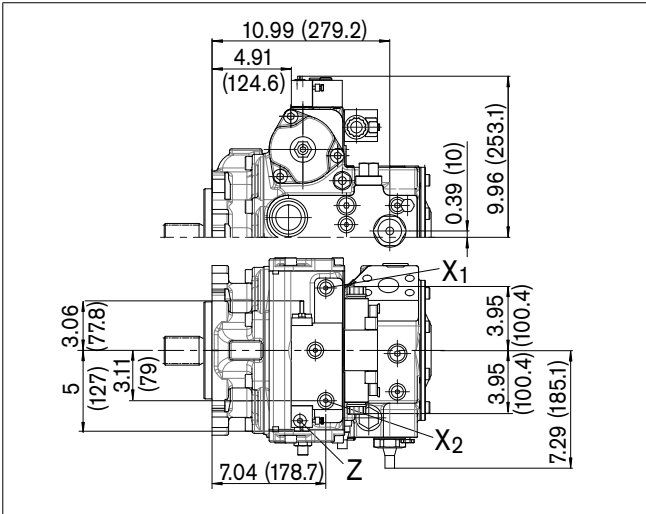

Dimensions size 175

Before finalizing your design, request a binding installation drawing. Dimensions in inch (mm).

EP – Proportional control electric

SAE flange ports A and B, 45° left (viewed on drive shaft)¹⁾

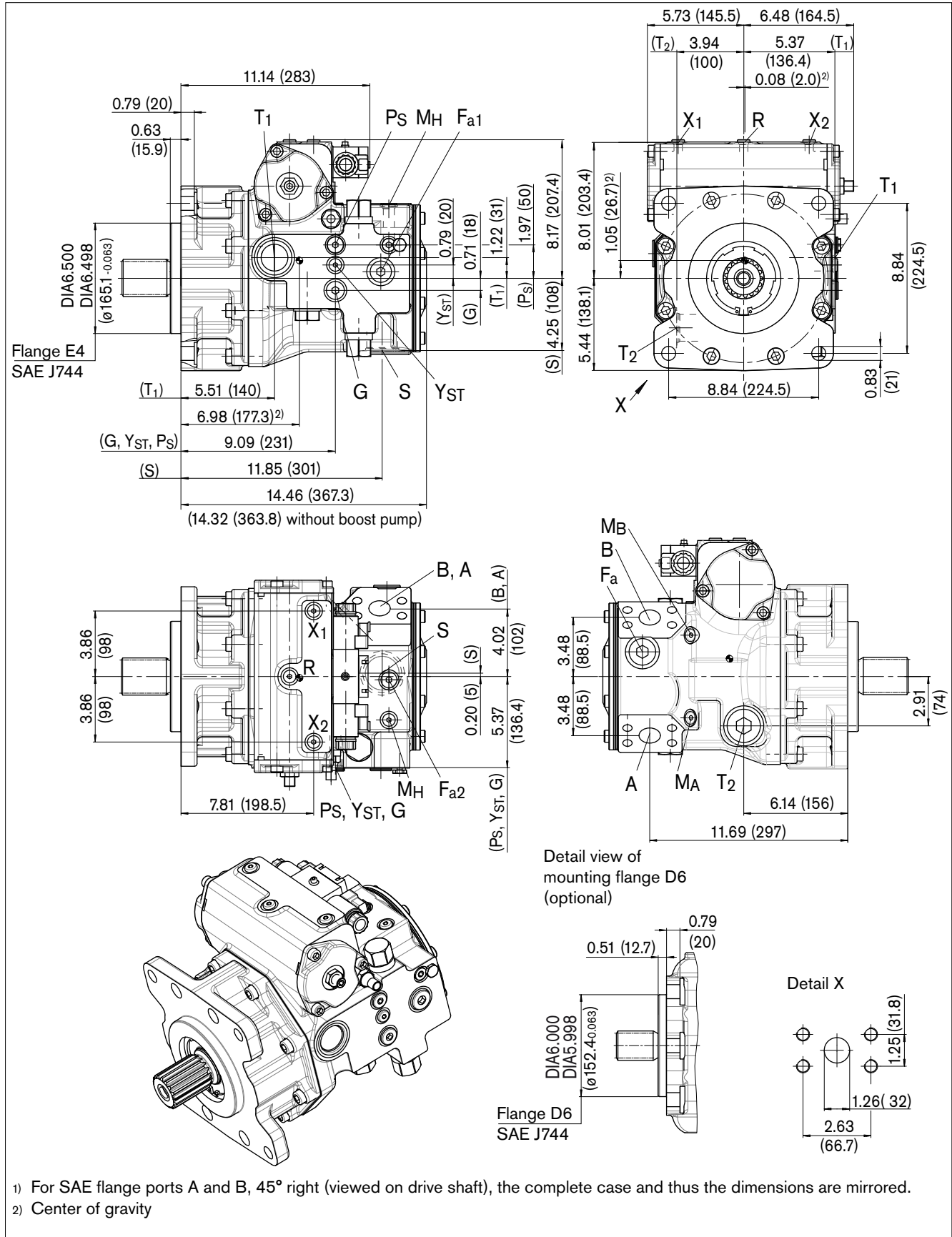

1) For SAE flange ports A and B, 45° right (viewed on drive shaft), the complete case and thus the dimensions are mirrored.

2) Center of gravity

Dimensions size 175

Before finalizing your design, request a binding installation drawing. Dimensions in inch (mm).

Drive shafts

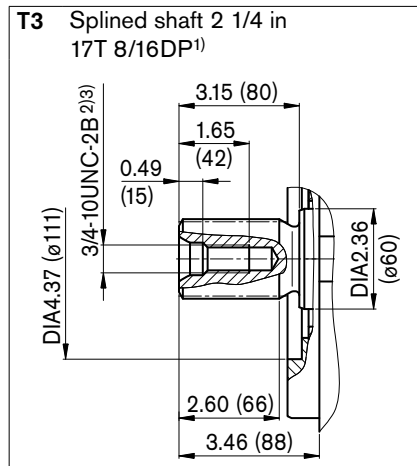
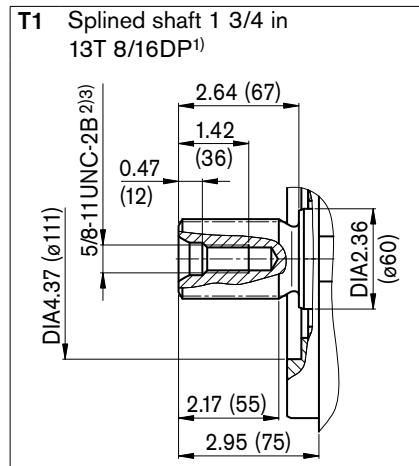

Ports

Designation	Port for	Standard	Size ³⁾	Maximum pressure [psi (bar)] ⁴⁾	State
A, B ¹⁰⁾	Service line Fastening thread A/B, screw grade 8 with hardened washer	SAE J518 ⁵⁾ ASME B.1.1	1 1/4 in 1/2-13UNC; 0.75 (19) deep	7250 (500)	O
S	Suction line	ISO 11926 ⁹⁾	1 7/8-12UN-2B; 0.79 (20) deep	75 (5)	O ⁶⁾
T ₁	Drain line	ISO 11926 ⁹⁾	1 5/8-12UN-2B; 0.77 (19.5) deep	45 (3)	O ⁷⁾
T ₂	Drain line	ISO 11926 ⁹⁾	1 5/8-12UN-2B; 0.77 (19.5) deep	45 (3)	X ⁷⁾
R	Air bleed	ISO 11926 ⁹⁾	9/16-18UNF-2B; 0.51 (13) deep	45 (3)	X
X ₁ , X ₂	Control pressure (upstream of orifice)	ISO 11926 ⁹⁾	9/16-18UNF-2B; 0.51 (13) deep	580 (40)	X
X ₁ , X ₂	Control pressure (upstream of orifice, HT only)	ISO 11926 ⁹⁾	9/16-18UNF-2B; 0.51 (13) deep	580 (40)	O
X ₃ , X ₄ ⁸⁾	Stroking chamber pressure	ISO 11926 ⁹⁾	9/16-18UNF-2B; 0.51 (13) deep	580 (40)	X
G	Boost pressure	ISO 11926 ⁹⁾	7/8-14UNF-2B; 0.67 (17) deep	580 (40)	X
P _S	Pilot pressure, inlet	ISO 11926 ⁹⁾	3/4-16UNF-2B; 0.59 (15) deep	580 (40)	X
P _S	Pilot pressure, inlet (DA6 only)	ISO 11926 ⁹⁾	3/4-16UNF-2B; 0.59 (15) deep	580 (40)	O
Y _{ST}	Pilot pressure, outlet	ISO 11926 ⁹⁾	9/16-18UNF-2B; 0.51 (13) deep	580 (40)	X
Y _{ST}	Pilot pressure, outlet (DA6 only)	ISO 11926 ⁹⁾	9/16-18UNF-2B; 0.51 (13) deep	580 (40)	O
Y _{HT}	Pilot pressure, outlet (HT only)	ISO 11926 ⁹⁾	9/16-18UNF-2B; 0.51 (13) deep	580 (40)	O
M _A , M _B	Measuring pressure A, B	ISO 11926 ⁹⁾	9/16-18UNF-2B; 0.51 (13) deep	7250 (500)	X
M _H	Measuring high pressure	ISO 11926 ⁹⁾	9/16-18UNF-2B; 0.51 (13) deep	7250 (500)	X
F _a ¹¹⁾	Boost pressure	ISO 11926 ⁹⁾	1 5/16-12UN-2B; 0.79 (20) deep	580 (40)	X
F _{a1} ¹¹⁾	Boost pressure	ISO 11926 ⁹⁾	No specification	580 (40)	X
F _{a2} ¹¹⁾	Boost pressure	ISO 11926 ⁹⁾	No specification	580 (40)	X
Y ₁ , Y ₂	Pilot signal (HP only)	ISO 11926 ⁹⁾	9/16-18UNF-2B; 0.51 (13) deep	580 (40)	O
Z	Inch signal (DA4 and 5 only)	ISO 11926 ⁹⁾	3/8-24UNF-2B; 0.39 (10) deep	580 (40)	O

1) ANSI B92.1a, 30° pressure angle, flat root, side fit, tolerance class 5

2) Thread according to ASME B.1.1

3) Observe the general instructions on page 66 for the maximum tightening torques.

4) Momentary pressure spikes may occur depending on the application. Keep this in mind when selecting measuring devices and fittings.

5) Only dimensions according to SAE J518.

6) Plugged with external supply option (Code E)

7) Depending on installation position, T₁ or T₂ must be connected (see also installation instructions on pages 63 and 64).

8) Optional, see page 55

9) The spot face can be deeper than specified in the appropriate standard.

10) For the maximum utilization of pressure, only grade 8 screws and hardened washers are to be used to tighten the SAE flange shells.

11) No standard ports, subject to change, please contact before use

O = Must be connected (plugged on delivery)

X = Plugged (in normal operation)

Dimensions size 175

Before finalizing your design, request a binding installation drawing. Dimensions in inch (mm).

HP

Proportional control hydraulic, pilot-pressure related

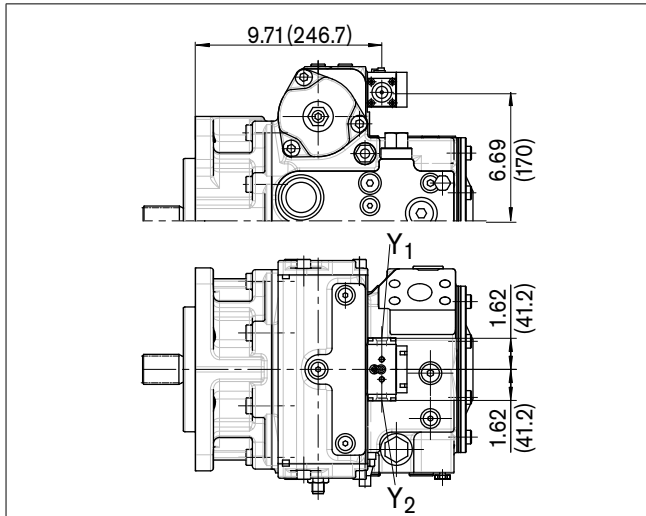

HW

Proportional control hydraulic, mechanical servo

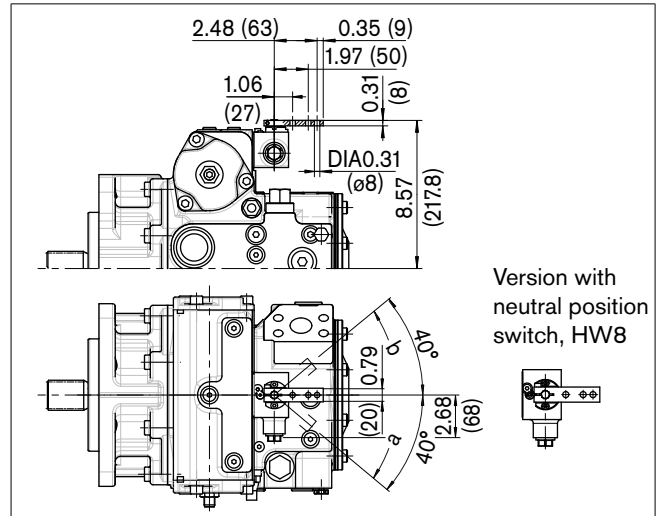

HT

Hydraulic control, direct controlled

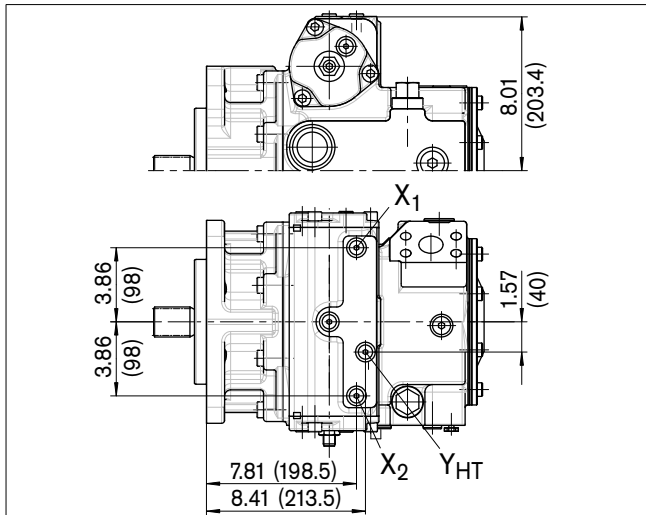

EZ

Two-point control electric

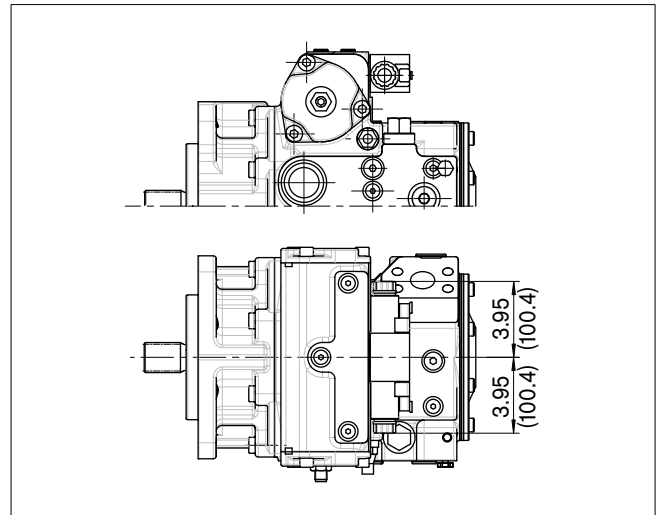

EV

Electric control, direct controlled

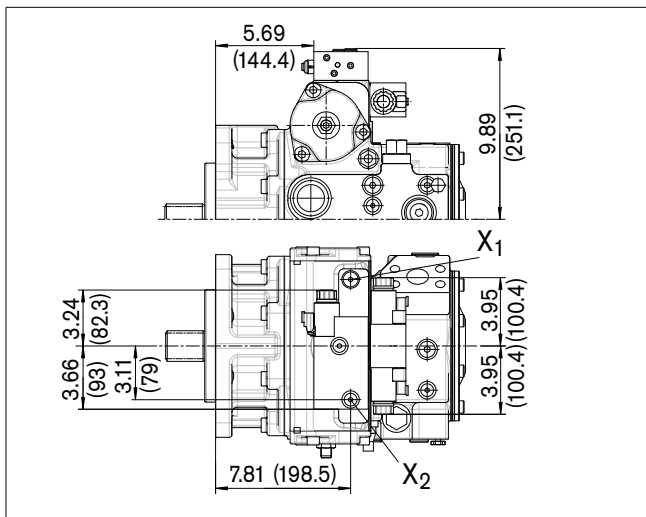

Dimensions size 175

Before finalizing your design, request a binding installation drawing. Dimensions in inch (mm).

DA – control valve

Version 1 – fixed setting

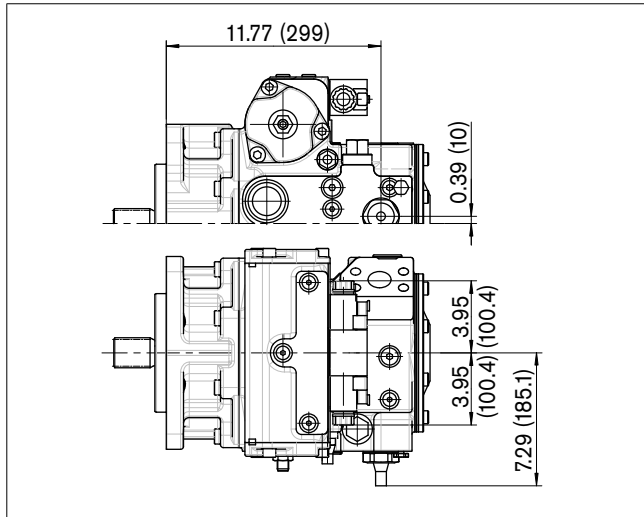

Version 4, 5 – fixed setting and inch valve mounted

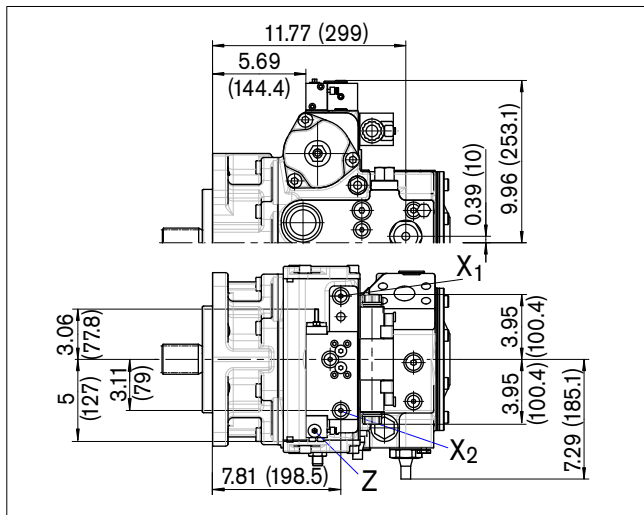

Dimensions size 210

Before finalizing your design, request a binding installation drawing. Dimensions in inch (mm).

EP – Proportional control electric

SAE flange ports A and B, 45° left (viewed on drive shaft)¹⁾

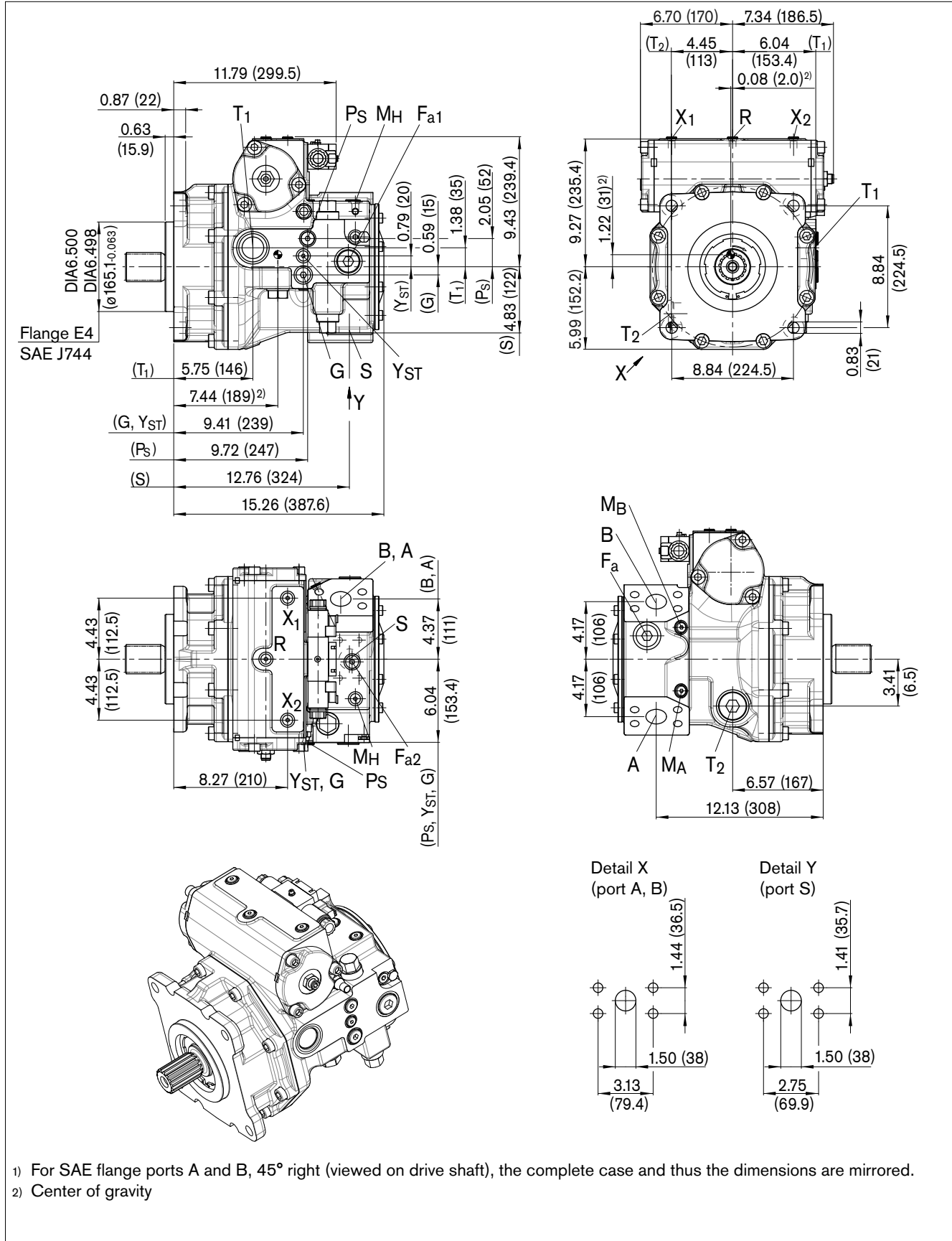

1) For SAE flange ports A and B, 45° right (viewed on drive shaft), the complete case and thus the dimensions are mirrored.

2) Center of gravity

Dimensions size 210

Before finalizing your design, request a binding installation drawing. Dimensions in inch (mm).

Drive shafts

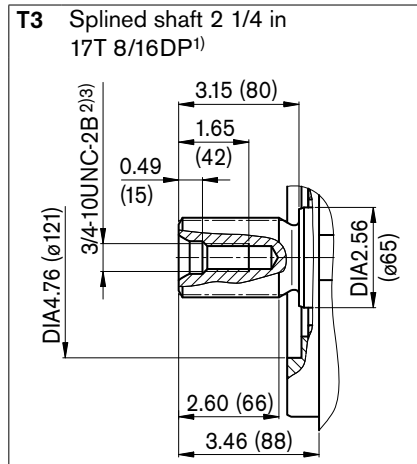
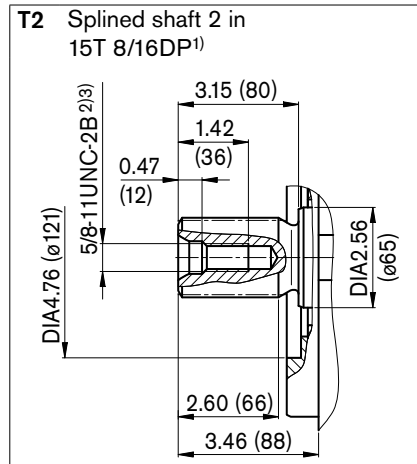

Ports

Designation	Port for	Standard	Size ³⁾	Maximum pressure [psi (bar)] ⁴⁾	State
A, B ¹⁰⁾	Service line Fastening thread A/B, screw grade 8 with hardened washer	SAE J518 ⁵⁾ ASME B1.1	1 1/2 in 5/8-11UNC; 1.14 (29) deep	7250 (500)	O
S	Suction line Fastening thread A/B	SAE J518 ⁵⁾ ASME B1.1	1 1/2 in 1/2-13UNC; 0.94 (24) deep	75 (5)	O ⁶⁾
T ₁	Drain line	ISO 11926 ⁹⁾	1 5/8-12UN-2B; 0.77 (19.5) deep	45 (3)	O ⁷⁾
T ₂	Drain line	ISO 11926 ⁹⁾	1 5/8-12UN-2B; 0.77 (19.5) deep	45 (3)	X ⁷⁾
R	Air bleed	ISO 11926 ⁹⁾	9/16-18UNF-2B; 0.51 (13) deep	45 (3)	X
X ₁ , X ₂	Control pressure (upstream of orifice)	ISO 11926 ⁹⁾	9/16-18UNF-2B; 0.51 (13) deep	580 (40)	X
X ₁ , X ₂	Control pressure (upstream of orifice, HT only)	ISO 11926 ⁹⁾	9/16-18UNF-2B; 0.51 (13) deep	580 (40)	O
X ₃ , X ₄ ⁸⁾	Stroking chamber pressure	ISO 11926 ⁹⁾	9/16-18UNF-2B; 0.51 (13) deep	580 (40)	X
G	Boost pressure	ISO 11926 ⁹⁾	7/8-14UNF-2B; 0.67 (17) deep	580 (40)	X
P _S	Pilot pressure, inlet	ISO 11926 ⁹⁾	3/4-16UNF-2B; 0.59 (15) deep	580 (40)	X
P _S	Pilot pressure, inlet (DA6 only)	ISO 11926 ⁹⁾	3/4-16UNF-2B; 0.59 (15) deep	580 (40)	O
Y _{ST}	Pilot pressure, outlet	ISO 11926 ⁹⁾	9/16-18UNF-2B; 0.51 (13) deep	580 (40)	X
Y _{ST}	Pilot pressure, outlet (DA6 only)	ISO 11926 ⁹⁾	9/16-18UNF-2B; 0.51 (13) deep	580 (40)	O
Y _{HT}	Pilot pressure, outlet (HT only)	ISO 11926 ⁹⁾	9/16-18UNF-2B; 0.51 (13) deep	580 (40)	O
M _A , M _B	Measuring pressure A, B	ISO 11926 ⁹⁾	9/16-18UNF-2B; 0.51 (13) deep	7250 (500)	X
M _H	Measuring high pressure	ISO 11926 ⁹⁾	9/16-18UNF-2B; 0.51 (13) deep	7250 (500)	X
F _a ¹¹⁾	Boost pressure	ISO 11926 ⁹⁾	1 5/16-12UN-2B; 0.79 (20) deep	580 (40)	X
F _{a1} ¹¹⁾	Boost pressure	ISO 11926 ⁹⁾	No specification	580 (40)	X
F _{a2} ¹¹⁾	Boost pressure	ISO 11926 ⁹⁾	No specification	580 (40)	X
Y ₁ , Y ₂	Pilot signal (HP only)	ISO 11926 ⁹⁾	9/16-18UNF-2B; 0.51 (13) deep	580 (40)	O
Z	Inch signal (DA4 and 5 only)	ISO 11926 ⁹⁾	3/8-24UNF-2B; 0.39 (10) deep	580 (40)	O

1) ANSI B92.1a, 30° pressure angle, flat root, side fit, tolerance class 5

2) Thread according to ASME B1.1

3) Observe the general instructions on page 66 for the maximum tightening torques.

4) Momentary pressure spikes may occur depending on the application. Keep this in mind when selecting measuring devices and fittings.

5) Only dimensions according to SAE J518.

6) Plugged with external supply option (Code E)

7) Depending on installation position, T₁ or T₂ must be connected (see also installation instructions on pages 63 and 64).

8) Optional, see page 55

9) The spot face can be deeper than specified in the appropriate standard.

10) For the maximum utilization of pressure, only grade 8 screws and hardened washers are to be used to tighten the SAE flange shells.

11) No standard ports, subject to change, please contact before use

O = Must be connected (plugged on delivery)

X = Plugged (in normal operation)

Dimensions size 280

Before finalizing your design, request a binding installation drawing. Dimensions in inch (mm).

EP – Proportional control electric

SAE flange ports A and B, 45° left (viewed on drive shaft)¹⁾

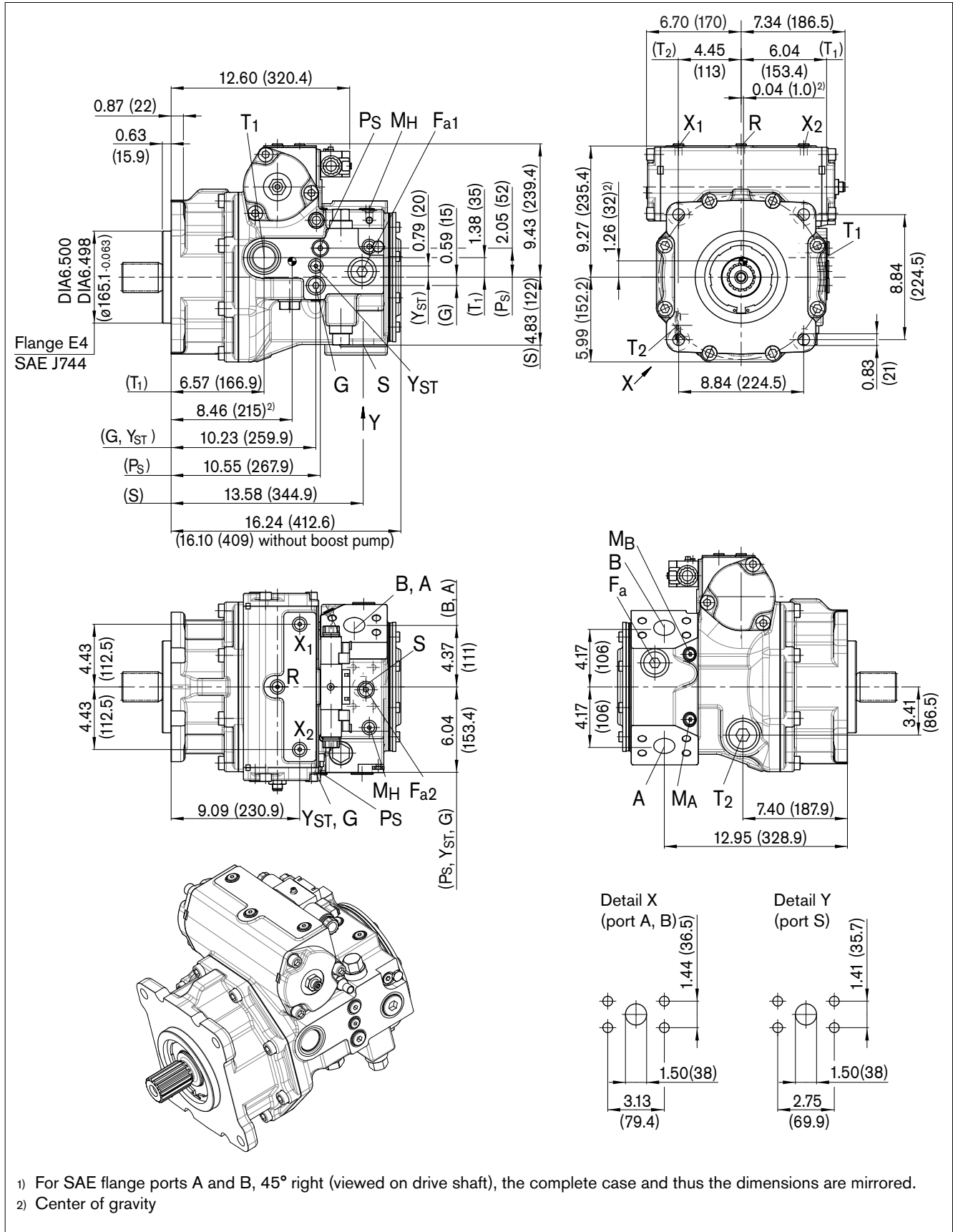

1) For SAE flange ports A and B, 45° right (viewed on drive shaft), the complete case and thus the dimensions are mirrored.
 2) Center of gravity

Dimensions size 280

Before finalizing your design, request a binding installation drawing. Dimensions in inch (mm).

Drive shafts

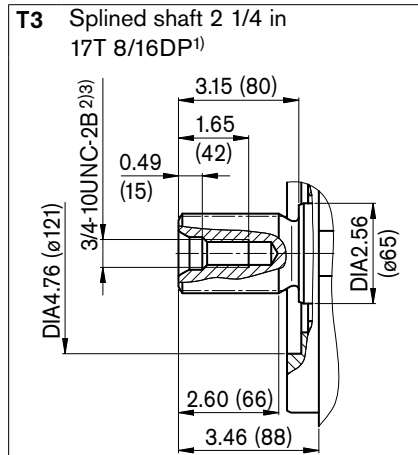
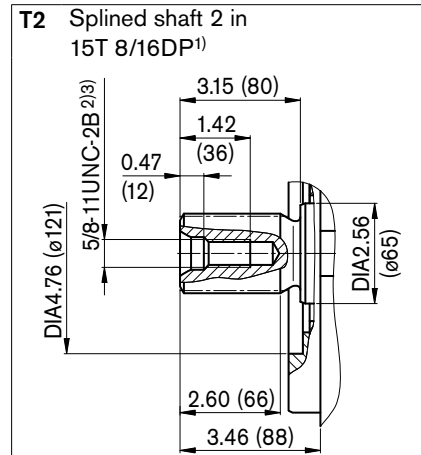

Ports

Designation	Port for	Standard	Size ³⁾	Maximum pressure [psi (bar)] ⁴⁾	State
A, B ¹⁰⁾	Service line Fastening thread A/B, screw grade 8 with hardened washer	SAE J518 ⁵⁾ ASME B1.1	1 1/2 in 5/8-11UNC; 1.14 (29) deep	7250 (500)	O
S	Suction line Fastening thread A/B	SAE J518 ⁵⁾ ASME B1.1	1 1/2 in 1/2-13UNC; 0.94 (24) deep	75 (5)	O ⁶⁾
T ₁	Drain line	ISO 11926 ⁹⁾	1 5/8-12UN-2B; 0.77 (19.5) deep	45 (3)	O ⁷⁾
T ₂	Drain line	ISO 11926 ⁹⁾	1 5/8-12UN-2B; 0.77 (19.5) deep	45 (3)	X ⁷⁾
R	Air bleed	ISO 11926 ⁹⁾	9/16-18UNF-2B; 0.51 (13) deep	45 (3)	X
X ₁ , X ₂	Control pressure (upstream of orifice)	ISO 11926 ⁹⁾	9/16-18UNF-2B; 0.51 (13) deep	580 (40)	X
X ₁ , X ₂	Control pressure (upstream of orifice, HT only)	ISO 11926 ⁹⁾	9/16-18UNF-2B; 0.51 (13) deep	580 (40)	O
X ₃ , X ₄ ⁸⁾	Stroking chamber pressure	ISO 11926 ⁹⁾	9/16-18UNF-2B; 0.51 (13) deep	580 (40)	X
G	Boost pressure	ISO 11926 ⁹⁾	7/8-14UNF-2B; 0.67 (17) deep	580 (40)	X
P _S	Pilot pressure, inlet	ISO 11926 ⁹⁾	3/4-16UNF-2B; 0.59 (15) deep	580 (40)	X
P _S	Pilot pressure, inlet (DA6 only)	ISO 11926 ⁹⁾	3/4-16UNF-2B; 0.59 (15) deep	580 (40)	O
Y _{ST}	Pilot pressure, outlet	ISO 11926 ⁹⁾	9/16-18UNF-2B; 0.51 (13) deep	580 (40)	X
Y _{ST}	Pilot pressure, outlet (DA6 only)	ISO 11926 ⁹⁾	9/16-18UNF-2B; 0.51 (13) deep	580 (40)	O
Y _{HT}	Pilot pressure, outlet (HT only)	ISO 11926 ⁹⁾	9/16-18UNF-2B; 0.51 (13) deep	580 (40)	O
M _A , M _B	Measuring pressure A, B	ISO 11926 ⁹⁾	9/16-18UNF-2B; 0.51 (13) deep	7250 (500)	X
M _H	Measuring high pressure	ISO 11926 ⁹⁾	9/16-18UNF-2B; 0.51 (13) deep	7250 (500)	X
F _a ¹¹⁾	Boost pressure	ISO 11926 ⁹⁾	1 5/16-12UN-2B; 0.79 (20) deep	580 (40)	X
F _{a1} ¹¹⁾	Boost pressure	ISO 11926 ⁹⁾	No specification	580 (40)	X
F _{a2} ¹¹⁾	Boost pressure	ISO 11926 ⁹⁾	No specification	580 (40)	X
Y ₁ , Y ₂	Pilot signal (HP only)	ISO 11926 ⁹⁾	9/16-18UNF-2B; 0.51 (13) deep	580 (40)	O
Z	Inch signal (DA4 and 5 only)	ISO 11926 ⁹⁾	3/8-24UNF-2B; 0.39 (10) deep	580 (40)	O

1) ANSI B92.1a, 30° pressure angle, flat root, side fit, tolerance class 5

2) Thread according to ASME B1.1

3) Observe the general instructions on page 66 for the maximum tightening torques.

4) Momentary pressure spikes may occur depending on the application. Keep this in mind when selecting measuring devices and fittings.

5) Only dimensions according to SAE J518.

6) Plugged with external supply option (Code E)

7) Depending on installation position, T₁ or T₂ must be connected (see also installation instructions on pages 63 and 64).

8) Optional, see page 55

9) The spot face can be deeper than specified in the appropriate standard.

10) For the maximum utilization of pressure, only grade 8 screws and hardened washers are to be used to tighten the SAE flange shells.

11) No standard ports, subject to change, please contact before use

O = Must be connected (plugged on delivery)

X = Plugged (in normal operation)

Through drive dimensions

Before finalizing your design, request a binding installation drawing. Dimensions in inch (mm).

Flange SAE J744 ¹⁾			Coupling for splined shaft ²⁾										
Diameter	Mounting variant		Diameter	Designation	045	065	085	110	145	175	210	280	0000
	Symbol ³⁾	Designation											
Without through drive													
82-2 (A)	∅	A1	5/8 in	9T 16/32DP S2	○	○	●	○	○	○	-	-	A1S2
			3/4 in	11T 16/32DP S3	○	○	○	●	-	-	●	-	A1S3
	∞	A2	5/8 in	9T 16/32DP S2	●	●	●	●	●	●	-	-	A2S2
			3/4 in	11T 16/32DP S3	●	○	-	-	-	-	-	-	-
101-2 (B)	∅	B1	7/8 in	13T 16/32DP S4	○	●	●	●	●	●	-	-	B1S4
			1 in	15T 16/32DP S5	○	○	●	○	●	●	-	-	B1S5
	∞	B2	7/8 in	13T 16/32DP S4	●	●	●	●	●	●	-	-	B2S4
			1 in	15T 16/32DP S5	●	●	●	●	●	●	-	-	B2S5
	∅	B5	7/8 in	13T 16/32DP S4	○	○	○	○	○	○	-	-	B5S4
			1 in	15T 16/32DP S5	○	○	●	●	○	○	-	-	B5S5
101-4 (B)	∅	B4	7/8 in	13T 16/32DP S4	○	○	○	○	●	○	-	-	B4S4
			1 in	15T 16/32DP S5	○	○	○	○	●	○	-	-	B4S5

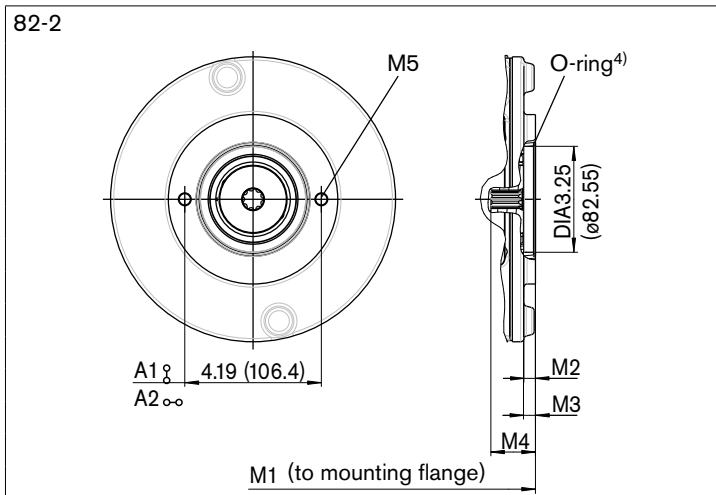

NG	M1 ⁵⁾	M2	M3	M4	M5 ⁶⁾	
45	in	10.5	0.35	0.37	1.39	3/8-16UNC-2B; 0.51 (13) deep
	mm	267.7	9	9.4	35.3	
65	in	11.1	0.35	0.37	1.63	On request
	mm	281.6	9	9.4	41.3	
85	in	12.0	0.35	0.37	1.41	On request
	mm	305.9	9	9.4	35.8	
110	in	12.8	0.35	0.37	1.36	On request
	mm	324.3	9	9.4	34.6	
145	in	13.6	0.35	0.37	1.37	On request
	mm	346.2	9	9.3	34.7	
175	in	14.5	0.35	0.36	1.31	On request
	mm	369.3	9	9.1	33.4	
210	in	15.3	0.35	0.29	1.30	On request
	mm	389.6	9	7.3	33	

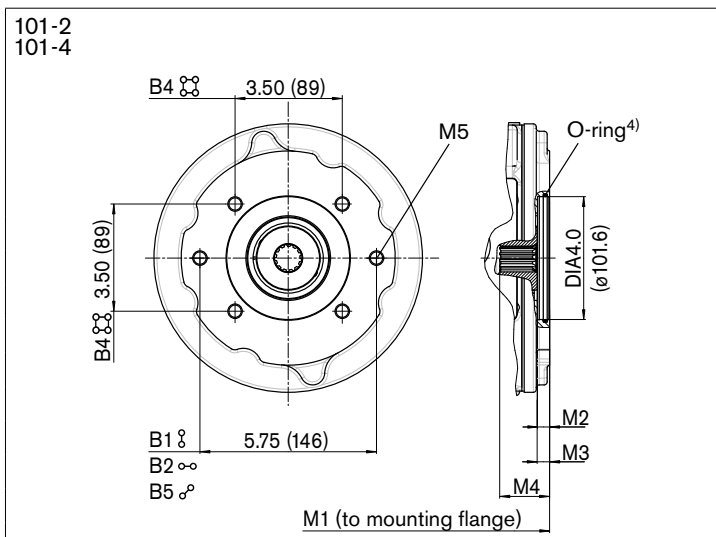

NG	M1 ⁵⁾	M2	M3	M4	M5 ⁶⁾	
45	in	10.7	0.39	0.49	1.70	On request
	mm	270.7	10	12.4	43.3	
65	in	11.2	0.39	0.49	1.74	On request
	mm	284.6	10	12.4	44.3	
85	in	12.2	0.39	0.43	1.89	1/2-13UNC-2B; 0.63 (16) deep
	mm	308.9	10	10.9	47.9	
110	in	12.9	0.39	0.43	1.96	On request
	mm	327.3	10	10.9	49.9	
145	in	13.8	0.39	0.41	1.62	On request
	mm	349.2	10	10.3	41.2	
175	in	14.7	0.39	0.41	1.63	On request
	mm	372.3	10	10.3	41.3	

- 1) The through-drive flange is only supplied with the fastening thread corresponding to the ordering code designation.
- 2) Coupling for splined shaft according to ANSI B92.1a, 30° pressure angle, flat root, side fit, tolerance class 5
- 3) Mounting drillings pattern viewed on through drive with control at top
- 4) O-ring included in the delivery contents
- 5) Installation length M1 is valid for standard mounting flange and integrated boost pump.
- 6) Thread according to ASME B1.1, observe the general instructions on page 66 for the maximum tightening torques.

Through drive dimensions

Before finalizing your design, request a binding installation drawing. Dimensions in inch (mm).

Flange SAE J744 ¹⁾			Coupling for splined shaft ²⁾											
Diameter	Mounting variant		Diameter	Designation	045	065	085	110	145	175	210	280		
	Symbol ³⁾	Designation												
127-2 (C)	⊗	C1	1 in	15T 16/32DP S5	-	-	-	-	○	-	-	-	C1S5	
			1 1/4 in	14T 12/24DP S7	○	○	●	●	●	○	○	○	C1S7	
		∞	C2	1 in	15T 16/32DP S5	-	-	-	-	●	○	-	-	C2S5
				1 1/4 in	14T 12/24DP S7	●	●	●	●	●	●	●	●	C2S7
	⊗	C5	1 3/8 in	21T 16/32DP V8	-	-	●	-	●	●	-	-	C2V8	
			1 3/4 in	13T 8/16DP T1	-	-	-	-	●	●	-	-	C2T1	
		⊗	C5	1 in	15T 16/32DP S5	-	-	-	-	○	-	-	-	C5S5
				1 1/4 in	14T 12/24DP S7	○	○	○	●	○	○	○	○	C5S7
127-4 (C)	⊗	C4	1 1/4 in	14T 12/24DP S7	-	-	●	●	●	●	-	-	C4S7	
			1 3/8 in	21T 16/32DP V8	-	-	●	○	-	-	-	-	C4V8	

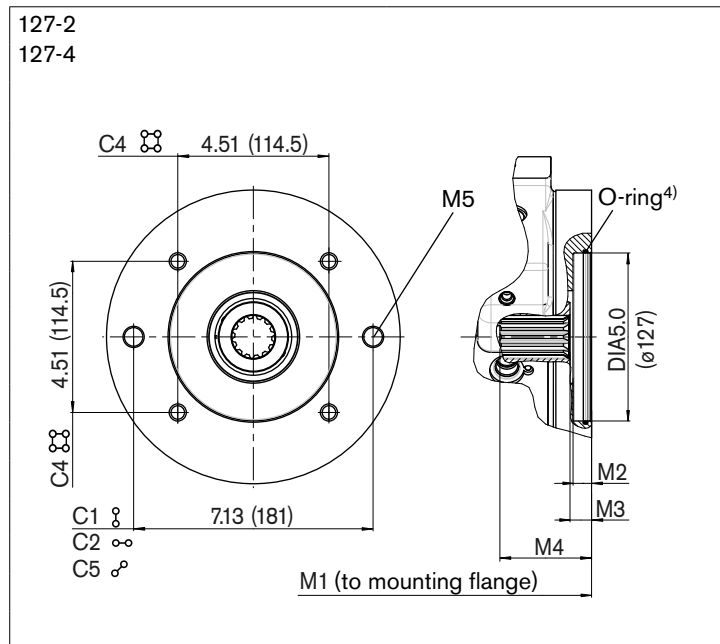

NG	M1 ⁵⁾	M2	M3	M4	
45	in	10.8	0.55	0.61	2.11
	mm	273.7	14	15.4	53.7
65	in	11.3	0.55	0.61	2.23
	mm	287.6	14	15.4	56.7
85	in	12.4	0.55	0.59	2.25
	mm	314.9	14	14.9	57.1
110	in	13.1	0.55	0.67	2.29
	mm	333.3	14	16.9	58.2
145	in	14.0	0.55	0.64	2.74
	mm	355.2	14	16.3	69.6
175	in	14.9	0.55	0.64	2.47
	mm	378.3	14	16.3	62.7
210	in	15.9	1.06	0.56	2.22
	mm	403.7	27	14.2	56.4
280	in	16.7	1.06	0.57	2.31
	mm	424.6	27	14.4	58.6

M5 ⁶⁾	
NG45, 65, 2-hole	On request
NG85 to 280, 2-hole	5/8-11UNC-2B; 0.83 (21) deep
NG85, 110, 4-hole	On request
NG145, 175, 4-hole	1/2-13UNC-2B; 0.83 (21) deep

- 1) The through-drive flange is only supplied with the fastening thread corresponding to the ordering code designation.
- 2) Coupling for splined shaft according to ANSI B92.1a, 30° pressure angle, flat root, side fit, tolerance class 5
- 3) Mounting drillings pattern viewed on through drive with control at top
- 4) O-ring included in the delivery contents
- 5) Installation length M1 is valid for standard mounting flange and integrated boost pump.
- 6) Thread according to ASME B1.1, observe the general instructions on page 66 for the maximum tightening torques.

Through drive dimensions

Before finalizing your design, request a binding installation drawing. Dimensions in inch (mm).

Flange SAE J744 ¹⁾			Coupling for splined shaft ²⁾										
Diameter	Mounting variant		Diameter	Designation	045	065	085	110	145	175	210	280	
	Symbol ³⁾	Designation											
152-2 (D)	∞	D2	1 3/4 in	13T 8/16DP T1	-	-	-	-	●	○	-	-	D2T1
152-4 (D)	∞	D4	1 3/8 in	21T 16/32DP V8	-	-	○	●	-	-	-	-	D4V8
			1 3/4 in	13T 8/16DP T1	-	-	-	-	●	●	●	●	D4T1
165-4 (E)	∞	E4	1 3/4 in	13T 8/16DP T1	-	-	-	-	○	●	-	-	E4T1

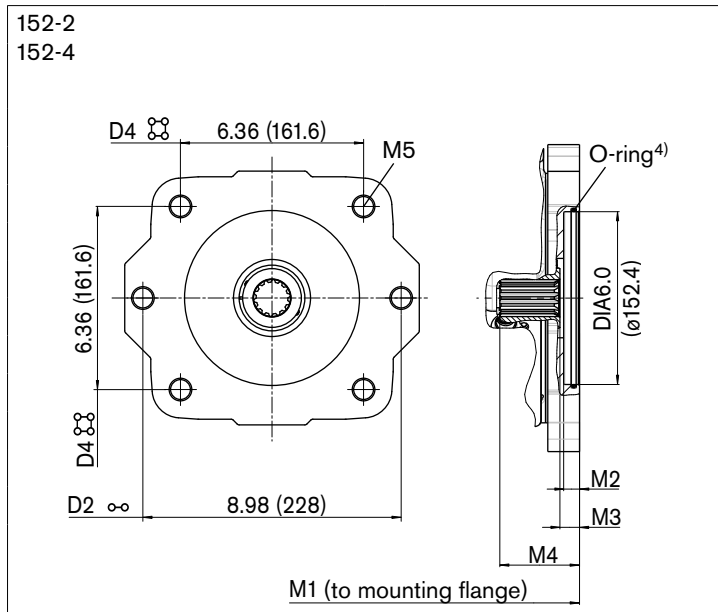

NG	M1 ⁵⁾	M2	M3	M4	M5 ⁶⁾	
85	in	On request				3/4-10UNC-2B; 0.87 (22) deep
	mm					
110	in	13.3	0.55	0.63	2.24	
	mm	337.4	14	15.9	56.9	
145	in	14.0	0.55	0.39	2.93	
	mm	356.2	14	10	74.4	
175	in	14.9	0.55	0.70	3.00	
	mm	379.3	14	17.8	76.3	
210	in	16.2	1.02	0.56	3.10	
	mm	411.6	26	14.3	78.8	
280	in	17.0	1.02	0.57	3.31	
	mm	432.5	26	14.5	84	

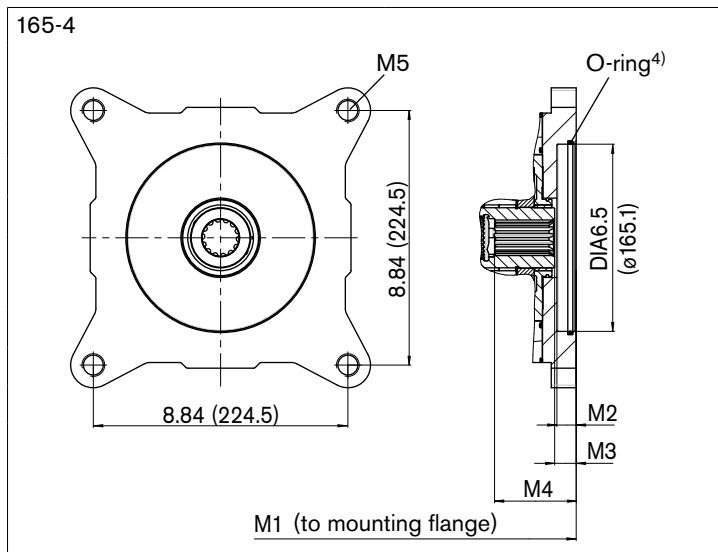

NG	M1 ⁵⁾	M2	M3	M4	M5 ⁶⁾	
175	in	15.0	0.67	0.76	3.07	On request
	mm	381	17	19.4	77.9	

- 1) The through-drive flange is only supplied with the fastening thread corresponding to the ordering code designation.
- 2) Coupling for splined shaft according to ANSI B92.1a, 30° pressure angle, flat root, side fit, tolerance class 5
- 3) Mounting drillings pattern viewed on through drive with control at top
- 4) O-ring included in the delivery contents
- 5) Installation length M1 is valid for standard mounting flange and integrated boost pump.
- 6) Thread according to ASME B1.1, observe the general instructions on page 66 for the maximum tightening torques.

Overview of mounting options

Through drive ¹⁾			Mounting options for 2nd pump						
Flange	Coupling for splined shaft	Short code	A4VG/40 NG (shaft)	AA4VG/32 NG (shaft)	AA10VG NG (shaft)	AA10VO/31 NG (shaft)	A10VO/53 NG (shaft)	AA11VO NG (shaft)	External gear pump ²⁾
82-2 (A)	5/8 in	A_S2	–	–	–	18 (U)	10 (U)	–	Series F NG4 to 22
	3/4 in	A_S3	–	–	–	18 (S, R)	10 (S) 18 (S, R)	–	–
101-2 (B)	7/8 in	B_S4	–	–	18 (S)	28 (S, R) 45 (U, W)	28 (S, R) 45 (U, W)	–	Series N NG20 to 36 Series G NG32 to 50
	1 in	B_S5	–	28 (S)	28, 45 (S)	45 (S, R)	45 (S, R) 60 (U, W)	40 (S)	–
101-4 (B)	7/8 in	B4S4	–	–	–	–	–	–	–
	1 in	B4S5	–	–	–	–	–	–	–
127-2 (C)	1 in	C_S5	–	40 (U)	–	71 (U, W)	–	–	–
	1 1/4 in	C_S7	45 (S7) 65 (S7)	40, 56, 71 (S)	63 (S)	71 (S, R) 100 (U, W)	85 (U, W)	60 (S)	–
	1 3/8 in	C_V8	85, 110 (V8)	56, 71 (T)	63 (T)	–	–	60 (T)	–
	1 3/4 in	C_T1	85, 110 (T1)	–	–	–	–	–	–
127-4 (C)	1 1/4 in	C4S7	65 (S7)	71 (S)	–	–	60 (S, R)	–	–
	1 3/8 in	C4V8	85, 110 (V8)	71 (T)	–	–	–	–	–
152-2 (D)	1 3/4 in	D2T1	110, 145, 175 (T1)	90, 125 (S)	–	–	–	–	–
152-4 (D)	1 3/8 in	D4V8	110 (V8)	–	–	–	–	75 (T)	–
	1 3/4 in	D4T1	110, 145, 175 (T1)	90, 125 (S)	–	140 (S)	–	95, 130, 145 (S)	–
165-4 (E)	1 3/4 in	E4T1	175 (T1)	180, 250 (S)	–	–	–	190, 260 (S)	–

1) Availability of the individual sizes, see ordering code on page 4.

2) Bosch Rexroth recommends special versions of the gear pumps. Please contact us.

Combination pumps A4VG + A4VG

Before finalizing your design, request a binding installation drawing. Dimensions in inch (mm).

Total length A¹⁾ with standard mounting flange

A4VG (1st pump)	A4VG (2nd pump) ²⁾								
		NG45	NG65	NG85	NG110	NG145	NG175	NG210	NG280
NG45	in	21.1	–	–	–	–	–	–	–
	mm	535.4	–	–	–	–	–	–	–
NG65	in	21.6	22.2	–	–	–	–	–	–
	mm	549.3	563.4	–	–	–	–	–	–
NG85	in	22.7	23.2	24.2	–	–	–	–	–
	mm	576.6	590.5	614.8	–	–	–	–	–
NG110	in	23.4	24.0	24.9	25.7	–	–	–	–
	mm	595	608.9	633.2	652.6	–	–	–	–
NG145	in	24.3	24.8	25.8	26.6	27.6	–	–	–
	mm	616.9	630.8	655.1	674.5	700.4	–	–	–
NG175	in	25.2	25.7	26.7	27.5	28.5	29.5	–	–
	mm	640	653.9	678.2	697.6	723.5	748.3	–	–
NG210	in	26.0	26.5	27.5	28.7	29.8	On request	On request	–
	mm	660.3	674.2	698.5	729.9	755.8	On request	On request	–
NG280	in	27.0	27.6	28.5	29.8	30.8	On request	On request	On request
	mm	686.3	700.2	724.5	755.9	781.8	On request	On request	On request

1) Total length is valid for standard mounting flange and integrated boost pump.

2) 2nd pump without through drive and with boost pump, F0000/V0000

By using combination pumps, it is possible to have independent circuits without the need for splitter gearboxes.

When ordering combination pumps, the type designations of the 1st and 2nd pumps must be linked by a "+".

Ordering example:

A4VG065EP1DP000/40ARNC6S71FC2S7AS00-0+

A4VG045EP1DP000/40ARNC2S71F0000AS00-0

A tandem pump consisting of two equal sizes is permissible without additional supports assuming that the dynamic acceleration does not exceed maximum $10 g = 322 \text{ ft/s}^2 (= 98.1 \text{ m/s}^2)$.

We recommend the use of the 4-hole mounting flanges for size 85 and larger.

For combination pumps consisting of more than two pumps, the mounting flange must be rated for the permissible mass torque.

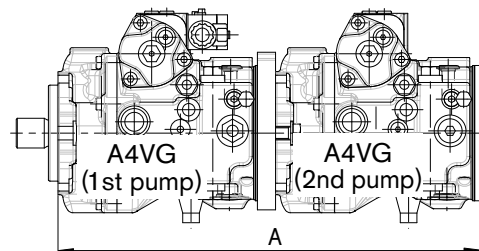

Pressure cut-off

The pressure cut-off is a pressure control which, after reaching the set pressure, adjusts the displacement of the pump back to $V_{g \text{ min}}$.

This valve prevents the operation of the high-pressure relief valves when accelerating or decelerating.

The high-pressure relief valves protect against the pressure spikes which occur during fast swiveling of the swashplate and limit the maximum pressure in the system.

The setting range of the pressure cut-off may be anywhere within the entire operating pressure range. However, it must be set 435 psi (30 bar) lower than the setting of the high-pressure relief valves (see setting diagram, page 54).

Please state the setting value of the pressure cut-off in plain text when ordering.

Schematic with pressure cut-off Example: electric control, EP_D

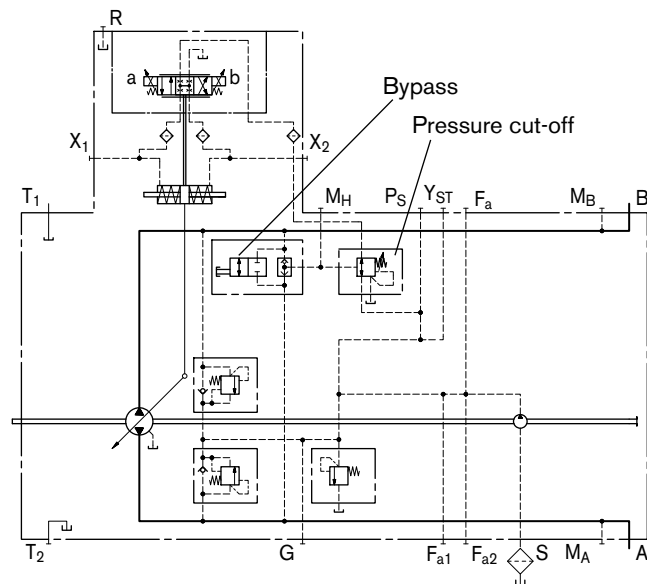

Schematic without pressure cut-off

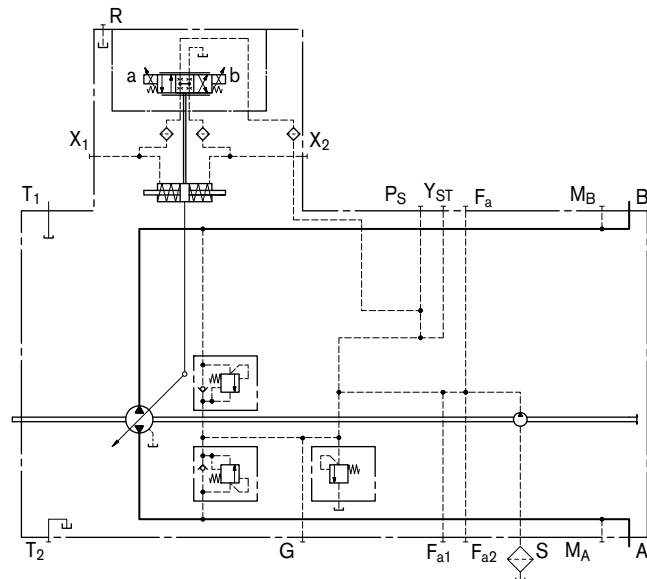

Bypass function

A connection between the two high-pressure channels A and B can be established using the bypass valve (e. g. for machine towing).

Towing speed

The maximum towing speed is dependent on the gear ratio in the vehicle and must be calculated by the vehicle manufacturer. The corresponding flow of $Q = 7.9 \text{ gpm}$ (30 L/min) may not be exceeded.

Towing distance

The vehicle may only be towed out of the immediate danger zone.

High-pressure relief valves

The two high-pressure relief valves protect the hydrostatic transmission (pump and motor) from overload. They limit the maximum pressure in the respective high-pressure line and serve simultaneously as boost valves.

High-pressure relief valves are not working valves and are only suitable for pressure spikes or high rates of pressure change.

Setting diagram

Version without pressure cut-off

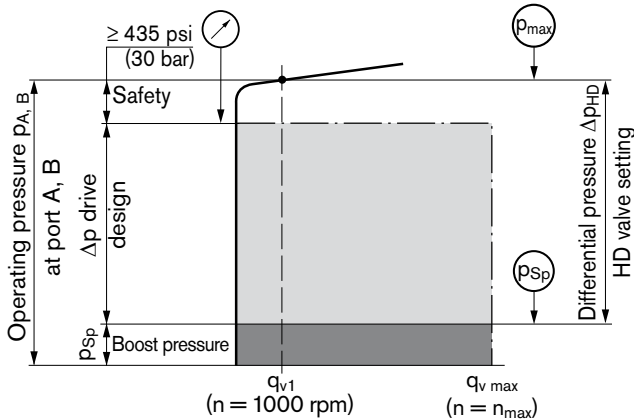

Example:

Operating pressure $p_{A,B}$ _____ 6500 psi (450 bar)
 Boost pressure p_{Sp} _____ 290 psi (20 bar)
 Differential pressure Δp_{HD} _____ 6210 psi (430 bar)

$$\begin{array}{rcl}
 p_{A,B} & p_{Sp} & \Delta p_{HD} \\
 6500 \text{ psi} & - 290 \text{ psi} & = \mathbf{6210 \text{ psi}} \\
 (450 \text{ bar}) & (20 \text{ bar}) & \mathbf{(430 \text{ bar})}
 \end{array}$$

Version with pressure cut-off

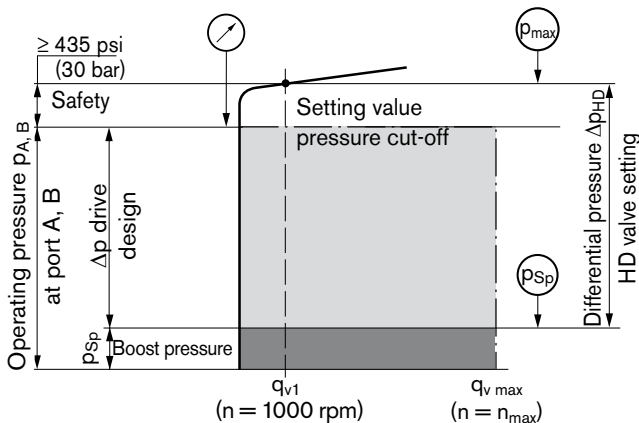

Example:

Operating pressure $p_{A,B}$ _____ 6500 psi (450 bar)
 Boost pressure p_{Sp} _____ 290 psi (20 bar)
 Differential pressure Δp_{HD} _____ 6645 psi (460 bar)

$$\begin{array}{rcl}
 p_{A,B} & p_{Sp} & \text{safety} & \Delta p_{HD} \\
 6500 \text{ psi} & - 290 \text{ psi} & + 435 \text{ psi} & = \mathbf{6645 \text{ psi}} \\
 (450 \text{ bar}) & (20 \text{ bar}) & (30 \text{ bar}) & \mathbf{(460 \text{ bar})}
 \end{array}$$

When ordering, state differential pressure setting in plain text:

The following values are available for selection of the differential pressure setting (fixed setting):

Preferred values [psi (bar)]:

5800 (400), 5950 (410), 6100 (420), 6250 (430), 6400 (440), 6500 (450), 6650 (460), 6800 (470)

Optional values [psi (bar)]:

4350 (300), 4650 (320), 4950 (340), 5200 (360), 5500 (380)

If not specified in the order, valves will be set to the differential pressure $\Delta p = 6100 \text{ psi (420 bar)}$.

High-pressure relief valve A

Differential pressure setting _____ $\Delta p_{HD} = \dots \text{ psi (bar)}$

Cracking pressure of the HD valve (at q_{V1}) $p_{max} = \dots \text{ psi (bar)}$
 $(p_{max} = \Delta p_{HD} + p_{Sp})$

High-pressure relief valve B

Differential pressure setting _____ $\Delta p_{HD} = \dots \text{ psi (bar)}$

Cracking pressure of the HD valve (at q_{V1}) $p_{max} = \dots \text{ psi (bar)}$
 $(p_{max} = \Delta p_{HD} + p_{Sp})$

Note

The valve settings are made at $n = 1000 \text{ rpm}$ and at $V_{g \text{ max}} (q_{V1})$. There may be deviations in the cracking pressures with other operating parameters.

Schematic

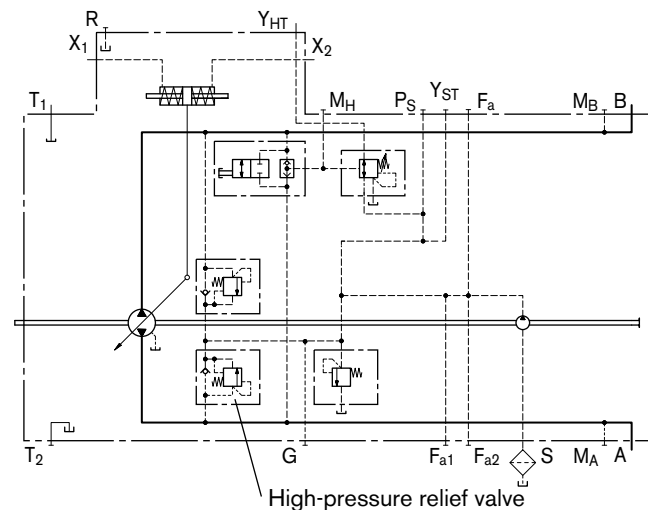

Mechanical stroke limiter

The mechanical stroke limiter is an auxiliary function allowing the maximum displacement of the pump to be steplessly reduced, regardless of the control module used.

With two threaded pins, the stroke of the stroke piston and thus the maximum swivel angle at the pump is limited.

Dimensions

NG	M1	M2	M3
45	4.81 (122.1) (4.61 (117.2)) ¹⁾	0.98 (24.9)	5.63 (143)
65	5.24 (133)	0.98 (24.9)	5.63 (143)
85	5.48 (139.2)	1.09 (27.7)	6.19 (157.3)
110	6.05 (153.6)	1.09 (27.7)	6.19 (157.3)
145	6.10 (155)	1.33 (33.8)	6.70 (170.1)
175	6.88 (174.8)	1.33 (33.8)	6.70 (170.1)
210	7.24 (183.9)	1.5 (38.1)	7.86 (199.6)
280	8.06 (204.7)	1.5 (38.1)	7.86 (199.6)

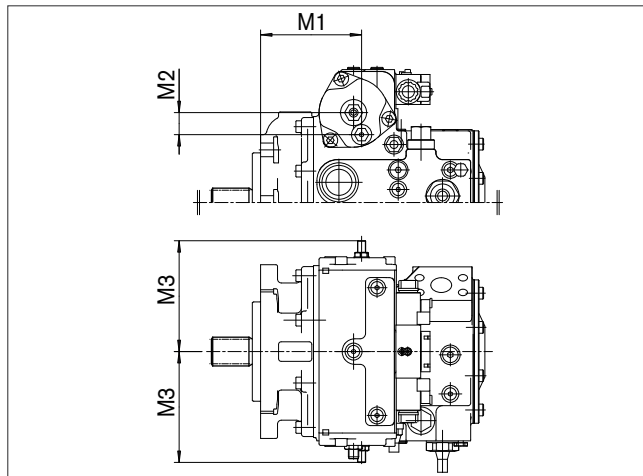

Schematic

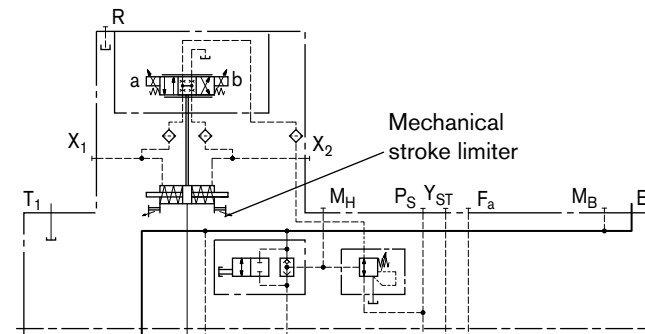

Ports X₃ and X₄ for stroking chamber pressure

Dimensions

NG	T1	T2	T3
45	5.17 (131.3) (4.98 (126.4)) ¹⁾	0.86 (21.8)	4.61 (117)
65	5.60 (142.2)	0.86 (21.8)	4.61 (117)
85	5.80 (147.4)	0.86 (21.8)	5.04 (128)
110	6.37 (161.8)	0.86 (21.8)	5.04 (128)
145	6.49 (164.9)	1.04 (26.4)	5.59 (142)
175	7.27 (184.7)	1.04 (26.4)	5.59 (142)
210	7.70 (195.7)	1.20 (30.6)	6.54 (166)
280	8.53 (216.6)	1.20 (30.6)	6.54 (166)

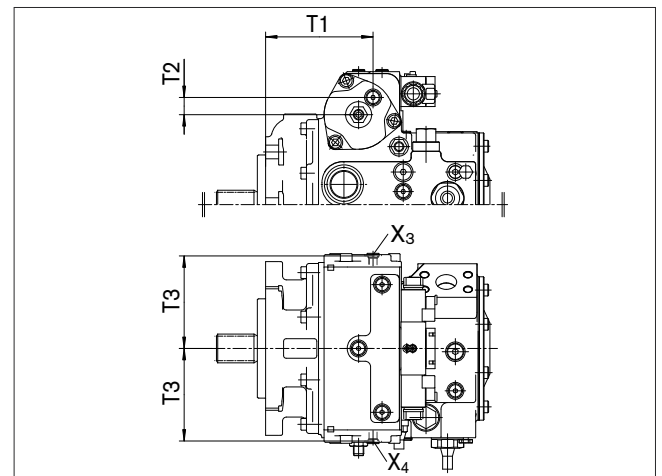

Schematic

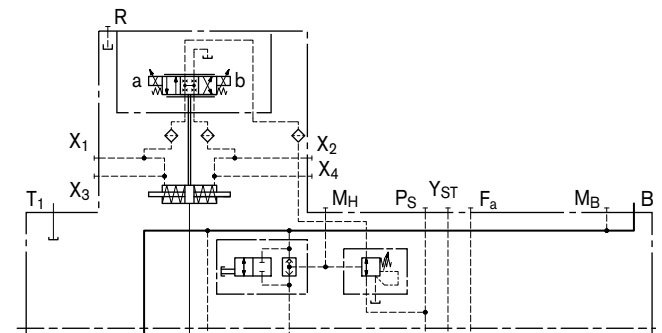

Designation	Port for	Standard ²⁾	Size ³⁾	Maximum pressure [psi (bar)] ⁴⁾	State ⁵⁾
X ₃ , X ₄	Stroking chamber pressure	ISO 11926	9/16-18UNF-2B; 0.51 (13) deep	580 (40)	X

- 1) For version with mounting flange B2.
 - 2) The spot face can be deeper than specified in the appropriate standard.
 - 3) Observe the general instructions on page 66 for the maximum tightening torques.
 - 4) Momentary pressure spikes may occur depending on the application. Keep this in mind when selecting measuring devices and fittings.
 - 5) X = Plugged (in normal operation)
- Before finalizing your design, request a binding installation drawing. Dimensions in inch (mm).

Filtration boost circuit / external supply

Version S (standard)

Filtration in the suction line of the boost pump

Standard version (preferred)

Filter type _____ filter **without** bypass

Recommendation _____ **with** contamination indicator

Recommended differential pressure at filter cartridge

At $v = 140 \text{ SUS}$, $n = n_{\text{max}}$ _____ $\Delta p \leq 1.5 \text{ psi}$
 ($30 \text{ mm}^2/\text{s}$, $n = n_{\text{max}}$ _____ $\Delta p \leq 0.1 \text{ bar}$)

At $v = 4600 \text{ SUS}$, $n = n_{\text{max}}$ _____ $\Delta p \leq 4.5 \text{ psi}$
 ($1000 \text{ mm}^2/\text{s}$, $n = n_{\text{max}}$ _____ $\Delta p \leq 0.3 \text{ bar}$)

Pressure at suction port S

Continuous $p_{S \text{ min}}$ ($v \leq 140 \text{ SUS}$) _____ $\geq 12 \text{ psi absolute}$
 ($v \leq 30 \text{ mm}^2/\text{s}$) _____ $\geq 0.8 \text{ bar absolute}$

Short-term, on cold start ($t < 3 \text{ min}$) _____ $\geq 7.5 \text{ psi (0.5 bar) absolute}$

Maximum $p_{S \text{ max}}$ _____ $\leq 75 \text{ psi (5 bar) absolute}$

The filter is not included in the delivery contents.

Schematic standard version S

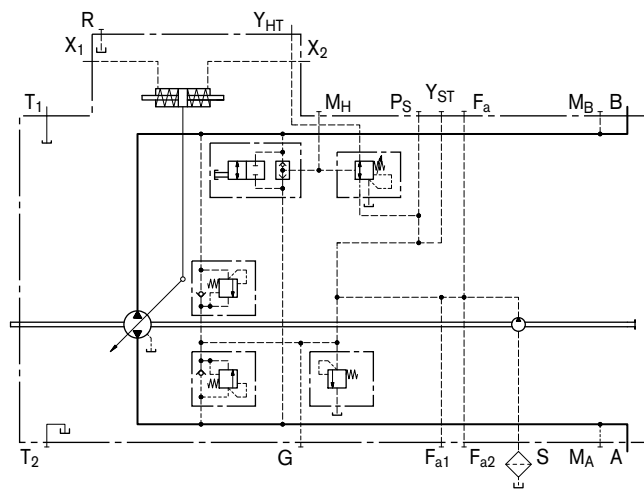

Version D

Filtration in the pressure line of the boost pump, ports for external boost circuit filter

Boost pressure inlet _____ port F_a

Boost pressure outlet _____ port F_e

Filter type _____

Filter with bypass are **not recommended**. For applications with bypass please contact us.

Recommendation _____ **with** contamination indicator

Note

For versions with HT control (with pilot pressure not from boost circuit), the following filter type should be used:

Filter **with** bypass and **with** contamination indicator

Filter arrangement

Separate in the pressure line (inline filter)

Permissible differential pressure at filter cartridge

At $v = 140 \text{ SUS}$ ($30 \text{ mm}^2/\text{s}$) _____ $\Delta p \leq 15 \text{ psi (1 bar)}$

At cold start _____ $\Delta p \leq 45 \text{ psi (3 bar)}$

(valid for entire speed range $n_{\text{min}} - n_{\text{max}}$)

The filter is not included in the delivery contents.

Schematic version D (external boost circuit filter)

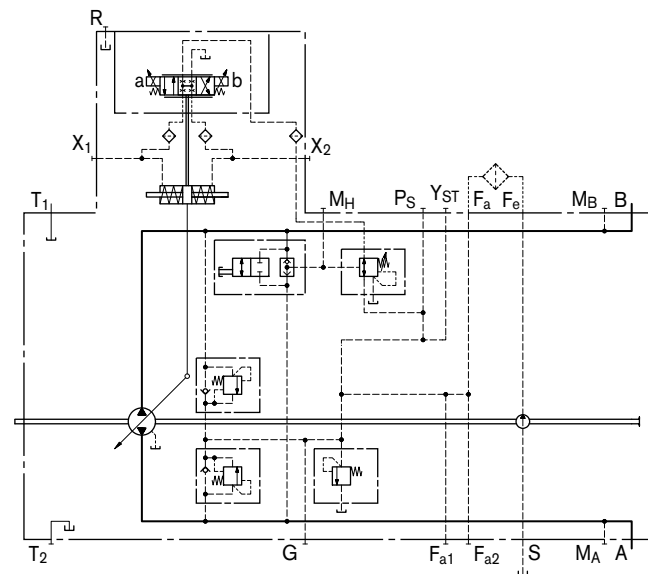

Filtration boost circuit / external supply

Version F

Filtration in pressure line of boost pump, filter mounted

Filter type _____ filter **without** bypass

Filtration grade (absolute) _____ 20 microns

Filter material _____ glass fiber

Pressure rating _____ 1450 psi (100 bar)

Filter arrangement _____ mounted on pump

Note

Filter is equipped with **cold start valve** and thereby protects the system from damage.

The valve opens at a differential pressure $\Delta p \geq 90$ psi (6 bar).

Recommendation

With contamination indicator (version B)
(differential pressure $\Delta p = 75$ psi (5 bar))

Filter characteristics

Differential pressure/flow characteristics to ISO 3968 (valid for clean filter cartridge).

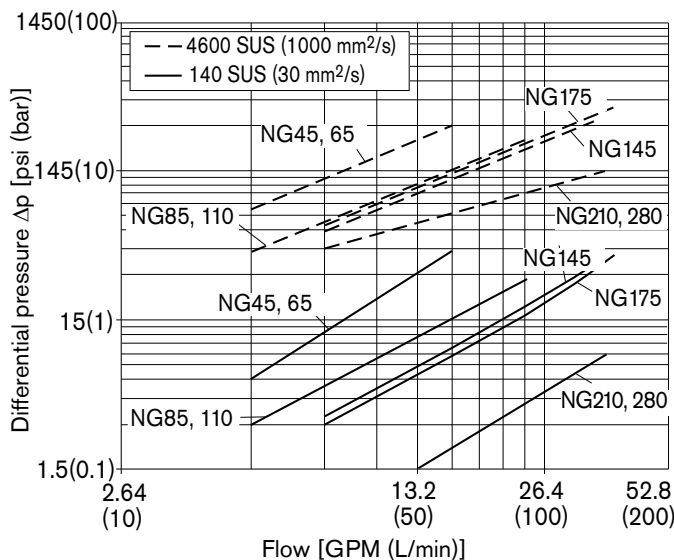

Version B

Filtration in the pressure line of the boost pump, filter mounted, with electric contamination indicator

Filtration similar to variation F, however additionally with electric contamination indicator.

Indication _____ electric

Connector design _____ DEUTSCH DT04-2P-EP04
(mating connector, see page 60)

Differential pressure (switching pressure) $\Delta p = 75$ psi (5 bar)

Maximum switching capacity at

12 V DC _____ 36 W

24 V DC _____ 72 W

Type of protection IP 67 _____ DIN/EN 60529

Schematic version B

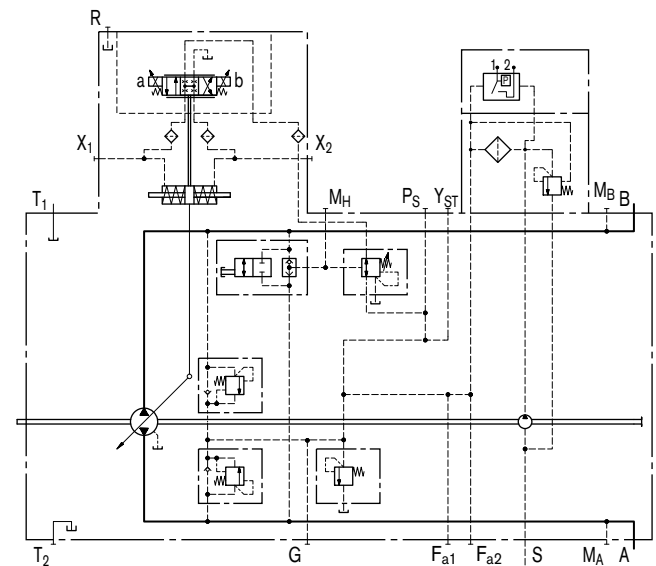

Schematic version F (with filter)

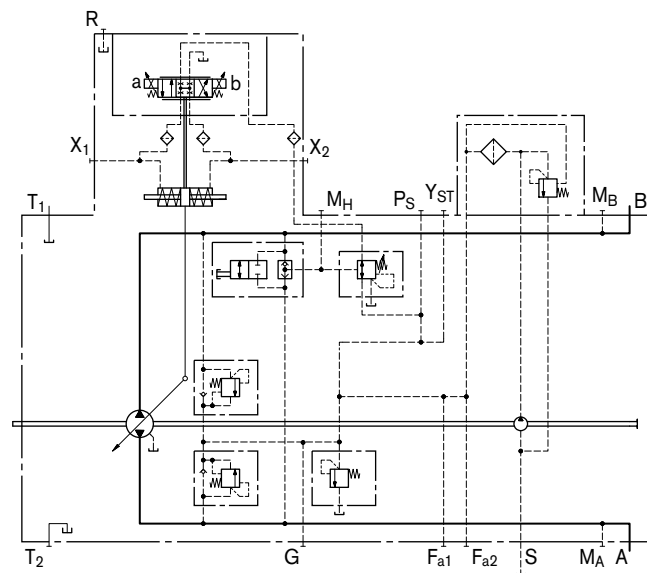

Filtration boost circuit / external supply

Before finalizing your design, request a binding installation drawing. Dimensions in inch (mm).

Dimensions

Version B

Filter mounted with electric contamination indicator

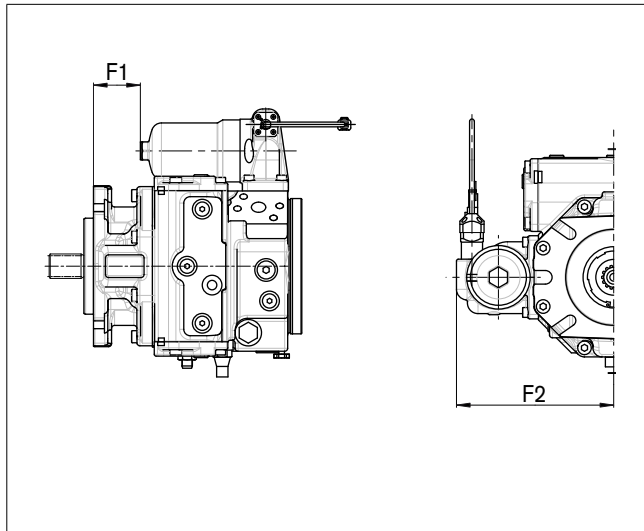

Version F

Filter mounted without contamination indicator

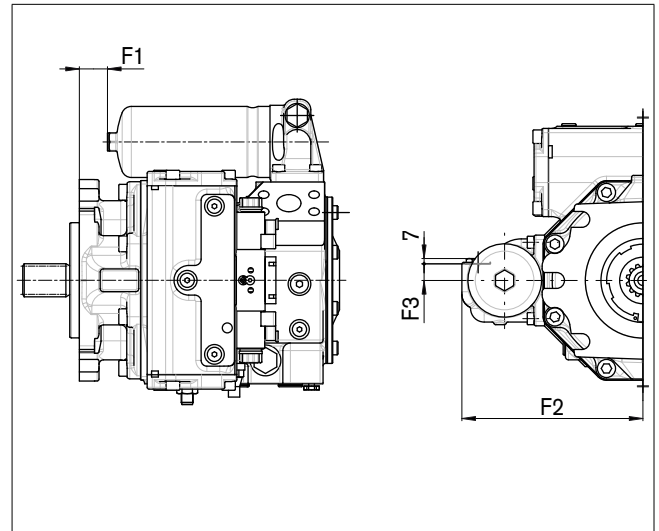

Version D

Ports for inline filter

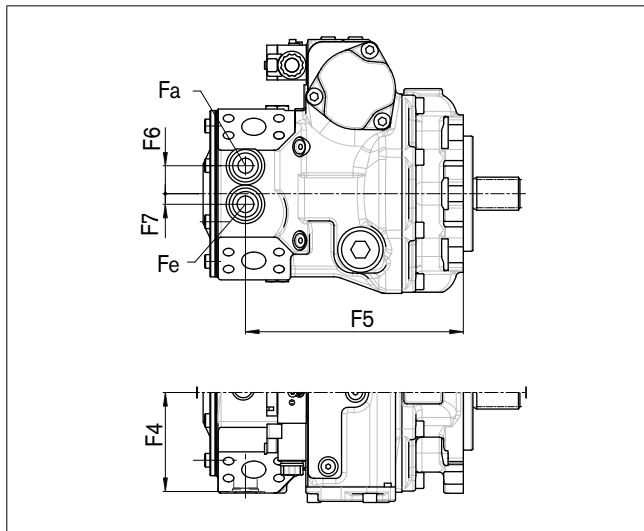

NG	F1	F2	F3	F4	F5	F6	F7	F _a , F _e ¹⁾²⁾
45	1.85 (47.1) (1.66 (42.2)) ³⁾	8.19 (208)	0.87 (22)	4.11 (104.5)	8.39 (213.1) (8.20 (208.2)) ³⁾	1.18 (30)	0.39 (10)	1 1/16-12UN-2B; 0.79 (20) deep
65	2.44 (62)	8.19 (208)	0.87 (22)	4.11 (104.5)	8.98 (228)	1.18 (30)	0.39 (10)	
85	2.44 (62.1)	9.04 (229.5)	0.87 (22)	4.76 (121)	9.85 (250.1)	1.46 (37)	0.55 (14)	
110	3.01 (76.5)	9.04 (229.5)	0.87 (22)	4.76 (121)	10.41 (264.5)	1.46 (37)	0.55 (14)	
145	1.46 (37.2)	9.43 (239.5)	0.87 (22)	5.16 (131)	11.35 (288.2)	1.46 (37)	0.55 (14)	1 5/16-12UN-2B; 0.79 (20) deep
175	2.24 (57)	9.43 (239.5)	0.87 (22)	5.16 (131)	12.13 (308)	1.46 (37)	0.55 (14)	
210	2.72 (69)	10.49 (266.5)	0.87 (22)	5.76 (146.3)	12.80 (325)	1.69 (43)	0.39 (10)	
280	3.54 (89.9)	10.49 (266.5)	0.87 (22)	5.76 (146.3)	13.62 (345.9)	1.69 (43)	0.39 (10)	

1) Observe the general instructions on page 66 for the maximum tightening torques.

2) The spot face can be deeper than specified in the appropriate standard.

3) For version with mounting flange B2.

Connector for solenoids

DEUTSCH DT04-2P-EP04

Molded, 2-pin, without bidirectional suppressor diode

There is the following type of protection with mounted mating connector:

IP67 _____ DIN/EN 60529

and IP69K _____ DIN 40050-9

Circuit symbol

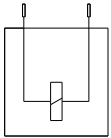

Mating connector

DEUTSCH DT06-2S-EP04

Bosch Rexroth Mat. No. R902601804

Consisting of: _____ DT designation

– 1 housing _____ DT06-2S-EP04

– 1 wedge _____ W2S

– 2 sockets _____ 0462-201-16141

The mating connector is not included in the delivery contents. This can be supplied by Bosch Rexroth on request.

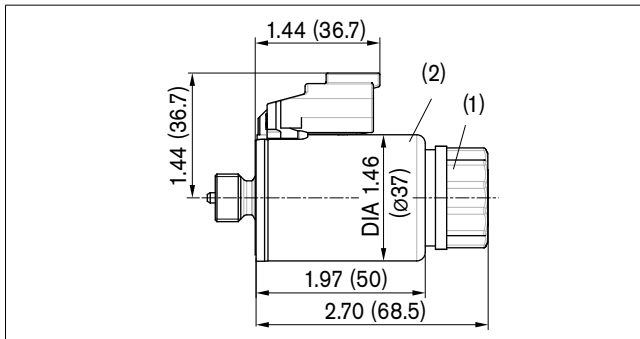

Changing connector orientation

If necessary, you can change the connector orientation by turning the solenoid housing.

To do this, proceed as follows:

1. Loosen the mounting nut (1) of the solenoid. To do this, turn the mounting nut (1) one turn counter-clockwise.
2. Turn the solenoid body (2) to the desired orientation.
3. Retighten the mounting nut. Tightening torque: 3.7+0.7 lb-ft (5+1 Nm). (WAF26, 12-sided DIN 3124)

On delivery, the connector orientation may differ from that shown in the brochure or drawing.

Before finalizing your design, request a binding installation drawing. Dimensions in mm.

Speed sensor

With the speed sensor DSA mounted, a signal proportional to pump speed can be generated. The DSA sensor measures the speed and direction of rotation.

Ordering code, technical data, dimensions and details on the connector, plus safety information about the sensor can be found in the relevant data sheet (DSA – RE 95133).

The sensor is mounted on the port provided for this purpose with a mounting bolt.

Dimensions

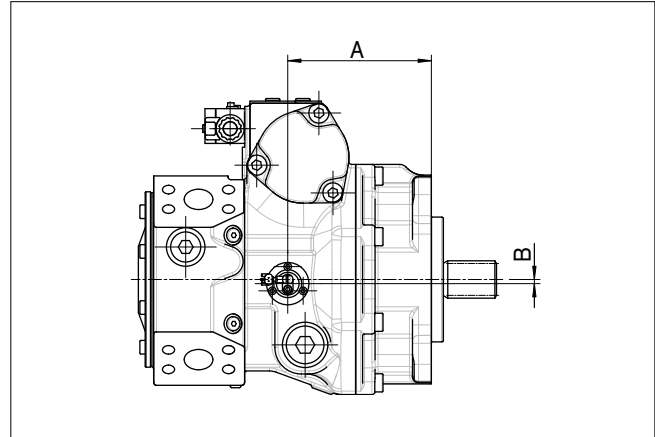

NG	A	B	Number of teeth
45	4.84 (123) (4.65 (118.1)) ¹⁾	0.22 (5.5)	32
65	5.43 (137.9)	0.22 (5.5)	45
85	5.79 (147.1)	0.22 (5.5)	50
110	6.36 (161.5)	0.22 (5.5)	53
145	7.13 (181.2)	0.22 (5.5)	58
175	7.91 (201.0)	0.22 (5.5)	61
210	7.48 (190)	0.22 (5.5)	64
280	8.30 (210.9)	0.22 (5.5)	71

¹⁾ For version with mounting flange B2.

Swivel angle sensor

Before finalizing your design, request a binding installation drawing. Dimensions in inch (mm).

For the swivel angle indicator, the pump swivel angle is measured by an electric swivel angle sensor.

As an output parameter, the Hall-effect swivel angle sensor delivers a voltage proportional to the swivel angle (see table of output voltages).

Please contact us if the swivel angle sensor is used for control.

Characteristics

Supply voltage U_b	10 to 30 V DC
Output voltage U_a	1 V ($V_{g\ max}$) 2.5 V ($V_{g\ 0}$) 4 V ($V_{g\ max}$)
Reverse voltage protection	Short circuit-resistant
EMC resistance	Details on request
Operating temperature range	-40 °F to 240 °F (-40 °C to +115 °C)
Vibration resistance sinusoidal vibration	322 ft/s ² (10 g) / 5 to 2000 Hz EN 60068-2-6
Shock resistance continuous shock	805 ft/s ² (25 g) IEC 68-2-29
Resistance to salt spray	96 h DIN 50 021-SS
Type of protection with mounted mating connector	IP67 – DIN/EN 60529 IP69K – DIN 40050-9
Housing material	Plastic

Output voltage

Direction of rotation	Flow direction ¹⁾	Operating pressure	Output voltage
	cw	B to A	M_A
	A to B	M_B	< 2.5 V
ccw	A to B	M_B	> 2.5 V
	B to A	M_A	< 2.5 V

1) For flow direction, see controls

Schematic

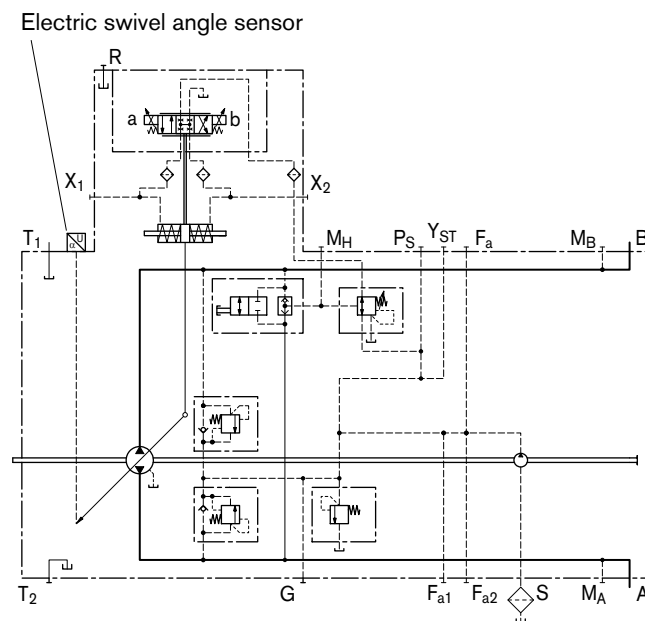

Dimensions

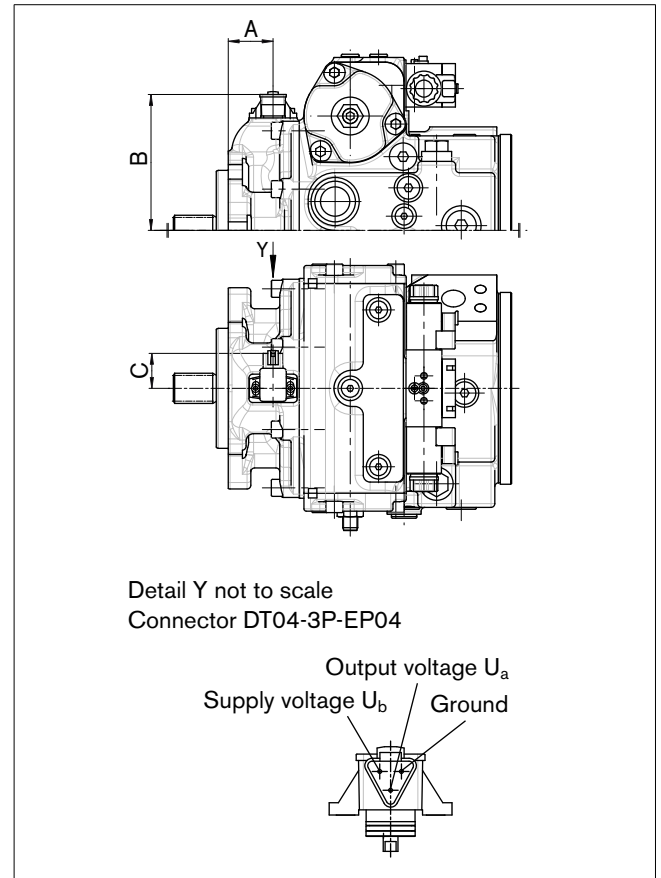

NG	A	B	C
45	1.57 (39.9) (1.38 (35)) ¹⁾	5.31 (134.8)	1.46 (37)
65	1.55 (39.4)	5.31 (134.8)	1.46 (37)
85	1.87 (47.4)	5.66 (143.8)	1.46 (37)
110	2.03 (51.5)	5.86 (148.8)	1.46 (37)
145	2.09 (53.1)	6.33 (160.8)	1.46 (37)
175	2.54 (64.4)	6.33 (160.8)	1.46 (37)
210	2.72 (69)	6.84 (173.8)	1.46 (37)
280	2.96 (75.1)	6.84 (173.8)	1.46 (37)

2) For version with mounting flange B2.

Mating connector

DEUTSCH DT06-3S-EP04
Bosch Rexroth Mat. No. R902603524

Consisting of:

- 1 housing _____ DT designation
- 1 wedge _____ W3S
- 3 sockets _____ 0462-201-16141

The mating connector is not included in the delivery contents. This can be supplied by Bosch Rexroth on request.

Installation dimensions for coupling assembly

Before finalizing your design, request a binding installation drawing. Dimensions in inch (mm).

To ensure that rotating components (coupling hub) and fixed components (housing, circlip) do not come into contact with each other, the installation conditions described here must be observed. This depends on the pump size and the splined shaft.

SAE splined shaft (spline according to ANSI B92.1a)

The outer diameter of the shoulder on coupling hub must be smaller than the inner diameter of the circlip d_2 in the area near the drive shaft collar (dimension $x_2 - x_3$).

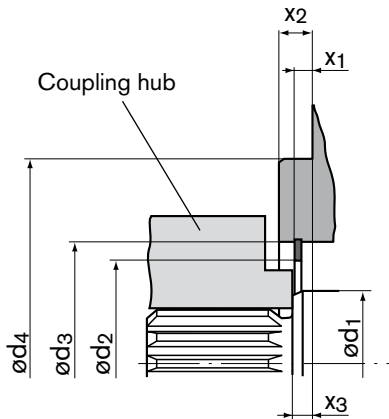

NG	Mounting flange		ød_1	$\text{ød}_2 \text{ min}$	ød_3	ød_4	x_1	x_2	$x_3 \text{ (approx.)}$
45	101-2 (B)	in	1.77	1.99	2.874 ± 0.004	4.00	0.161	$0.38_{-0.02}$	0.315
		mm	45	50.5	73 ± 0.1	101.6	4.1	$9.7_{-0.5}$	8
	127-2 (C)	in	1.77	1.99	2.874 ± 0.004	5.00	0.004	$0.5_{-0.02}$	0.315
		mm	45	50.5	73 ± 0.1	127	0.1	$12.7_{-0.5}$	8
65	127-2/4 (C)	in	1.77	2.30	3.189 ± 0.004	5.00	0.252	$0.5_{-0.02}$	0.315
		mm	45	58.5	81 ± 0.1	127	6.4	$12.7_{-0.5}$	8
85	127-2/4 (C)	in	1.97	2.54	3.583 ± 0.004	5.00	0.138	$0.5_{-0.02}$	0.315
		mm	50	64.4	91 ± 0.1	127	3.5	$12.7_{-0.5}$	8
	152-2/4 (D)	in	On request						
		mm	On request						
110	127-2/4 (C)	in	2.17	2.93	3.976 ± 0.004	5.00	0.16	$0.5_{-0.02}$	0.315
		mm	55	74.4	101 ± 0.1	127	4.0	$12.7_{-0.5}$	8
	152-2/4 (D)	in	2.17	2.93	3.976 ± 0.004	6.00	0.236	$0.5_{-0.02}$	0.315
		mm	55	74.4	101 ± 0.1	152.4	6.0	$12.7_{-0.5}$	8
145	152-2/4 (D)	in	2.36	3.32	4.370 ± 0.004	6.00	0.291	$0.5_{-0.02}$	0.315
		mm	60	84.4	111 ± 0.1	152.4	7.4	$12.7_{-0.5}$	8
	165-4 (E)	in	On request						
		mm	On request						
175	152-2/4 (D)	in	2.36	3.32	4.370 ± 0.004	6.00	0.276	$0.5_{-0.02}$	0.315
		mm	60	84.4	111 ± 0.1	152.4	7.0	$12.7_{-0.5}$	8
	165-4 (E)	in	2.36	3.32	4.370 ± 0.004	6.50	0.276	$0.63_{-0.02}$	0.315
		mm	60	84.4	111 ± 0.1	165.1	7.0	$15.9_{-0.5}$	8
210	165-4 (E)	in	2.56	4.12	4.76	6.5	0.22	$0.63_{-0.02}$	0.315
		mm	65	104.6	121 ± 0.1	165.1	5.5	$15.9_{-0.5}$	8
280	165-4 (E)	in	2.56	4.12	4.76	6.5	0.276	$0.63_{-0.02}$	0.315
		mm	65	104.6	121 ± 0.1	165.1	7.0	$15.9_{-0.5}$	8

Installation instructions

General

During commissioning and operation, the axial piston unit must be filled with hydraulic fluid and air bled. This must also be observed following a relatively long standstill as the axial piston unit may drain back to the reservoir via the hydraulic lines.

Particularly in the installation position "drive shaft upwards" filling and air bleeding must be carried out completely as there is, for example, a danger of dry running.

The case drain fluid in the pump housing must be directed to the reservoir via the highest available drain port (T_1 , T_2).

For combinations of multiple units, make sure that the respective case pressure in each unit is not exceeded. In the event of pressure differences at the drain ports of the units, the shared drain line must be changed so that the minimum permissible case pressure of all connected units is not exceeded in any situation. If this is not possible, separate drain lines must be laid if necessary.

To achieve favorable noise values, decouple all connecting lines using elastic elements and avoid above-reservoir installation.

In all operating conditions, the suction and drain lines must flow into the reservoir below the minimum fluid level. The permissible suction height h_S results from the overall loss of pressure; it must not, however, be higher than $h_{S\max} = 31.5$ in (800 mm). The minimum suction pressure at port S must also not fall below 12 psi (0.8 bar) absolute during operation (cold start 7.5 psi (0.5 bar) absolute).

Installation position

See the following examples 1 to 12. Further installation positions are available upon request.

Recommended installation position: 1 and 2.

Notes

- With the "drive shaft upwards" installation position, an R_1 -port is necessary (special version).
- If it is not possible to fill the stroking chambers via X_1 to X_4 in the final installation position, this must be done prior to installation.
- To prevent unexpected actuation and damage, the stroking chambers must be bled via the ports X_1 , X_2 or X_3 , X_4 depending on the installation position.
- In certain installation positions, an influence on the control characteristics can be expected. Gravity, dead weight and case pressure can cause minor shifts in control characteristics and changes in response time.

Below-reservoir installation (standard)

Below-reservoir installation means that the axial piston unit is installed outside of the reservoir below the minimum fluid level.

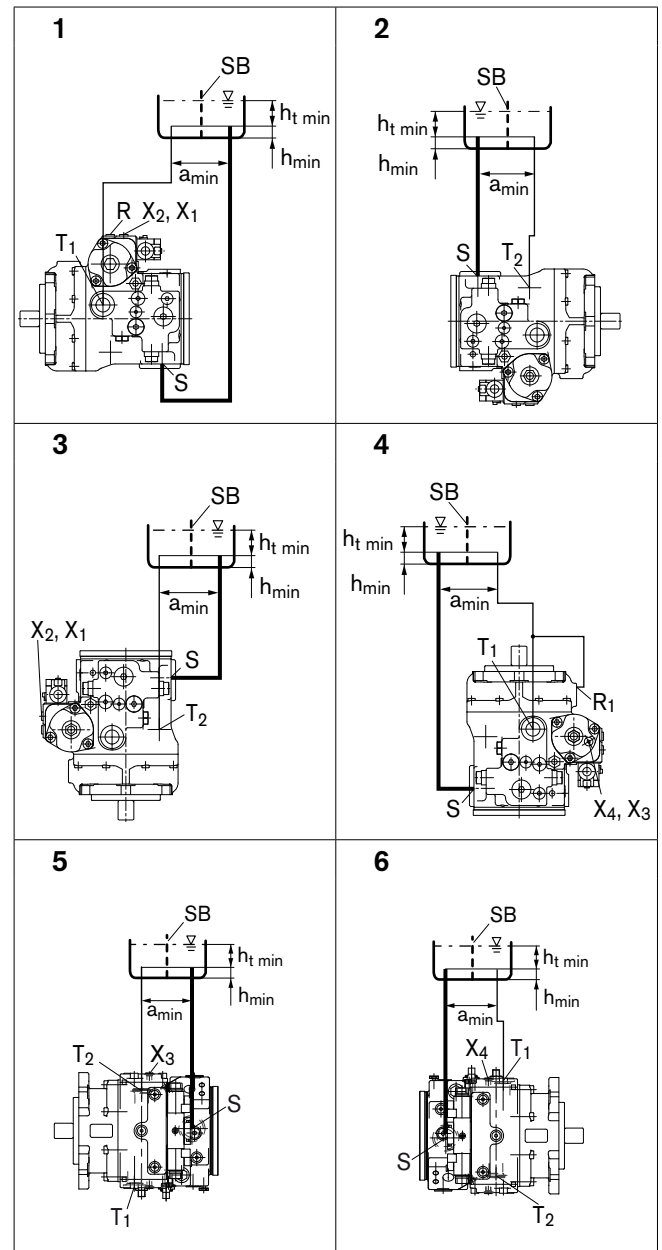

Installation Position	Bleeding the case	Bleeding the stroking chamber	Filling
1	R	X_1, X_2	$S + T_1 + X_1 + X_2$
2	-	-	$S + T_2$
3	-	X_1, X_2	$S + T_2 + X_1 + X_2$
4	R_1	X_3, X_4	$S + T_1 + X_3 + X_4$
5	-	X_3	$S + T_2 + X_3$
6	-	X_4	$S + T_1 + X_4$

Note instructions!

Key, see page 64.

Installation instructions

Above-reservoir installation

Above-reservoir installation means that the axial piston unit is installed above the minimum fluid level of the reservoir.

Observe the maximum permissible suction height $h_{S \max} = 31.5$ in (800 mm).

Recommendation for installation position 10 (drive shaft upward): A check valve in the drain line (cracking pressure 7.5 psi (0.5 bar)) can prevent draining of the pump housing.

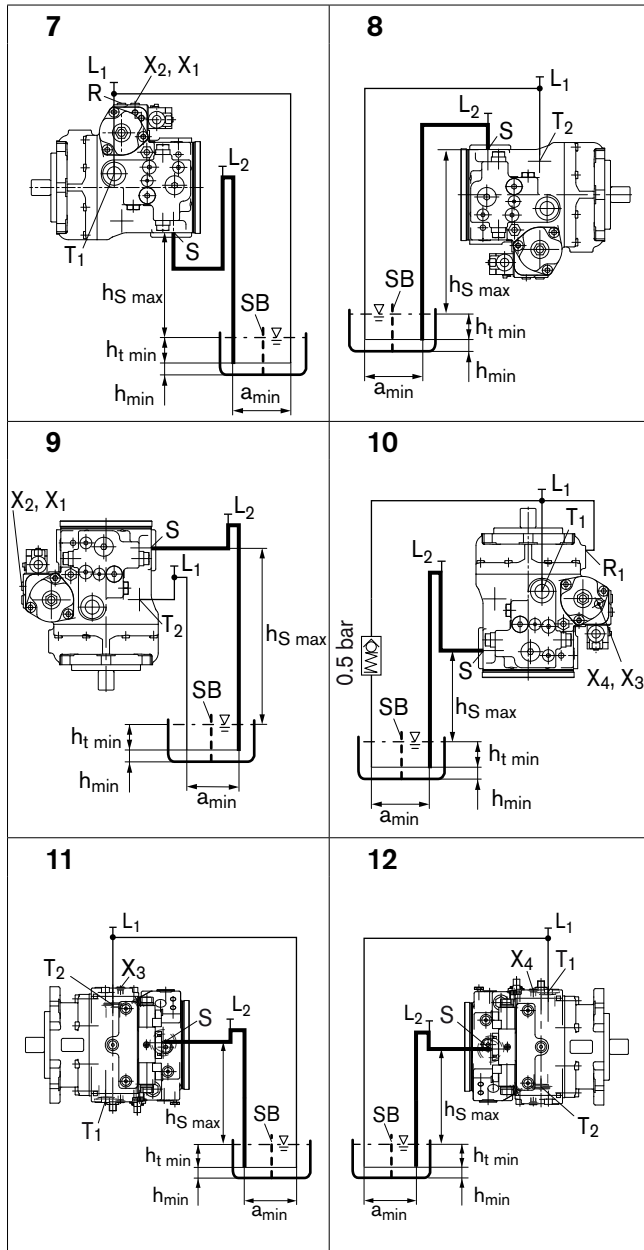

Installation Position	Bleeding the case	Bleeding the stroking chamber	Filling
7	$L_2 + R$	X_1, X_2	$L_1 + L_2 + X_1 + X_2$
8	$L_2 (S) + L_1 (T_2)$	-	$L_2 (S) + L_1 (T_2)$
9	$L_2 (S) + L_1 (T_2)$	X_1, X_2	$L_2 (S) + L_1 (T_2) + X_1 + X_2$
10	$L_2 + R_1$	X_3, X_4	$L_1 + L_2 + X_3 + X_4$
11	$L_2 (S) + L_1 (T_2)$	X_3	$L_2 (S) + L_1 (T_2) + X_3$
12	$L_2 (S) + L_1 (T_1)$	X_4	$L_2 (S) + L_1 (T_1) + X_4$

Comply with notes on page 63!

- L₁, L₂** Filling / air bleed
- R** Air bleed port
- S** Suction port
- T₁, T₂** Drain port
- SB** Baffle (baffle plate)
- h_{t min}** Minimum required immersion depth (7.87 in (200 mm))
- h_{min}** Minimum required spacing to reservoir bottom (3.94 in (100 mm))
- h_{S max}** Maximum permissible suction height (31.50 in (800 mm))
- a_{min}** When designing the reservoir, ensure adequate space between the suction line and the drain line. This prevents the heated, return flow from being drawn directly back into the suction line.

General instructions

Ports		Maximum permissible tightening torque of the female threads $M_{G \max}$	Required tightening torque of the threaded plugs M_V	WAF hexagon socket of the threaded plugs
Standard	Size of thread			
ISO 11926	3/8-24 UNF-2B	15 lb-ft	7 lb-ft	5/32 in
		20 Nm	10 Nm	
	9/16-18 UNF-2B	59 lb-ft	26 lb-ft	1/4 in
		80 Nm	35 Nm	
	3/4-16 UNF-2B	118 lb-ft	52 lb-ft	5/16 in
		160 Nm	70 Nm	
	7/8-14 UNF-2B	177 lb-ft	81 lb-ft	3/8 in
		240 Nm	110 Nm	
	1 1/16-12 UN-2B	266 lb-ft	125 lb-ft	9/16 in
		360 Nm	170 Nm	
	1 5/16-12 UN-2B	398 lb-ft	199 lb-ft	5/8 in
		540 Nm	270 Nm	
	1 5/8-12 UN-2B	708 lb-ft	236 lb-ft	3/4 in
		960 Nm	320 Nm	
	1 7/8-12 UN-2B	885 lb-ft	288 lb-ft	3/4 in
		1200 Nm	390 Nm	

General instructions

- The pump A4VG is designed to be used in closed circuit.
- The project planning, installation and commissioning of the axial piston unit requires the involvement of qualified personnel.
- Before using the axial piston unit, please read the corresponding instruction manual completely and thoroughly. If necessary, these can be requested from Bosch Rexroth.
- During and shortly after operation, there is a risk of burns on the axial piston unit and especially on the solenoids. Take appropriate safety measures (e. g. by wearing protective clothing).
- Depending on the operating conditions of the axial piston unit (operating pressure, fluid temperature), the characteristic may shift.
- Service line ports:
 - The ports and fastening threads are designed for the specified maximum pressure. The machine or system manufacturer must ensure that the connecting elements and lines correspond to the specified application conditions (pressure, flow, hydraulic fluid, temperature) with the necessary safety factors.
 - The service line ports and function ports can only be used to accommodate hydraulic lines.
- The data and notes contained herein must be adhered to.
- The product is not approved as a component for the safety concept of a general machine according to ISO 13849.
- The following tightening torques apply:
 - Fittings:
 - Observe the manufacturer's instructions regarding the tightening torques of the fittings used.
 - Mounting bolts:
 - For mounting bolts with thread according to ASME B1.1, we recommend checking the tightening torque in individual cases in accordance with VDI 2230.
 - Female threads in the axial piston unit:
 - The maximum permissible tightening torques $M_{G \max}$ are maximum values of the female threads and must not be exceeded. For values, see table on page 67.
 - Threaded plugs:
 - For the metallic threaded plugs supplied with the axial piston unit, the required tightening torques of threaded plugs M_V apply. For values, see table on page 67.

Bosch Rexroth Corporation
Mobile Applications
8 Southchase Court
Fountain Inn, SC 29644-9018, USA
Telephone (864) 967-2777
Facsimile (864) 967-8900
www.boschrexroth-us.com

© Bosch Rexroth Corporation

All rights reserved. Neither this document, nor any part of it, may be reproduced, duplicated, circulated or disseminated, whether by copy, electronic format or any other means, without the prior consent and authorization of Bosch Rexroth Corp.

The data and illustrations in this brochure/data sheet are intended only to describe or depict the products. No representation or warranty, either express or implied, relating to merchantability or fitness for intended use, is given or intended by virtue of the information contained in this brochure/data sheet. The information contained in this brochure/data sheet in no way relieves the user of its obligation to insure the proper use of the products for a specific use or application. All products contained in this brochure/data sheet are subject to normal wear and tear from usage.

Subject to change.